



माननीय मुख्यमंत्री
छत्तीसगढ़



माननीय मंत्री
लोक स्वास्थ्य यांत्रिकी विभाग

GOVERNMENT OF CHHATTISGARH PUBLIC HEALTH ENGINEERING DEPARTMENT



UNIFIED SCHEDULE OF RATES FOR WATER SUPPLY, SEWERAGE & ALLIED WORKS

In Force From – 01st June, 2020
Issued by

Engineer - in - Chief
Public Health Engineering Department
Nava Raipur, Chhattisgarh



माननीय मंत्री जी, छत्तीसगढ़ शासन, लोक स्वास्थ्य यांत्रिकी विभाग द्वारा नवीन यू.एस.ओ.आर.-2020 का विमोचन
दिनांक 01 जून 2020

**GOVERNMENT OF CHHATTISGARH
PUBLIC HEALTH ENGINEERING DEPARTMENT**



**UNIFIED SCHEDULE OF RATES
FOR
WATER SUPPLY, SEWERAGE & ALLIED WORKS**

In Forced From

01st June, 2020

**Issued
by**

**Engineer-in-Chief
Public Health Engineering
Department Chhattisgarh, Raipur**

Price: 1000/-

गुरु रूद्र कुमार
मंत्री

छत्तीसगढ़ शासन

लोक स्वास्थ्य यांत्रिकी एवं ग्रामोद्योग विभाग

कार्यालय : M-2/13, मंत्रालय, महानदी भवन,
नवा रायपुर अटल नगर, रायपुर (छ.ग.)
दूरभाष : 0771-2510906, 0771-2221106 (फै.)



निवास कार्यालय : 'सतनाम सदन'
B-5/5, वन कॉलोनी, जेल रोड,
रायपुर (छ.ग.)

दूरभाष : 0771-2420707
फैक्स : 0771-2434455

ई-मेल : cgministerphegram@gmail.com
gururudraku@gmail.com

क्रमांकVIP-९...../लो.स्वा.यां.ग्रामो.वि./2020

रायपुर, दिनांक : 31-05-2020

संदेश

यह अत्यंत हर्ष का विषय है कि लोक स्वास्थ्य यांत्रिकी विभाग द्वारा पेयजल योजनाओं के क्रियान्वयन से संबंधित समस्त कार्यों के लिए नवीन यू.एस.ओ.आर.-2020 का निर्माण किया गया है। नवीन यू.एस.ओ.आर.-2020 के लागू होने के पश्चात राज्य मद की पेयजल योजनाओं के कार्यों को जहाँ गति मिलेगी वही जल जीवन मिशन के अंतर्गत योजनाओं के क्रियान्वयन हेतु मार्ग प्रशस्त होगा। यह नवीन यू.एस.ओ.आर.-2020 पेयजल योजनाओं के लिए "मील का पत्थर" साबित होगा।

नवीन यू.एस.ओ.आर.-2020 के निर्माण में जिन अधिकारियों ने कड़ी मेहनत के साथ इस कार्य को संपादित किया है उनकी मैं सराहना करता हूँ।

विभाग के सभी अभियंताओं को मेरी हार्दिक शुभकानाएँ।

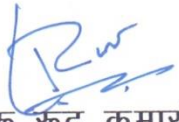
(गुरु रूद्र कुमार)

अविनाश चम्पावत

आई.ए.एस.

सचिव

छत्तीसगढ़ शासन



जल संसाधन विभाग एवं
लोक स्वास्थ्य यांत्रिकी विभाग
मंत्रालय, महानदी भवन,
नवा रायपुर अटल नगर,
फोन नं. 0771-2510838
ई-मेल- secy-wrd.cg@gov.in
क्रमांक 6 / सचिव / लो.स्वा.यां.
दिनांक 31 / 05 / 2020

संदेश

लोक स्वास्थ्य यांत्रिकी विभाग द्वारा सात वर्षों के पश्चात् पेयजल योजनाओं के क्रियान्वयन से संबंधित समस्त कार्यों के लिए नवीन यू.एस.ओ.आर.-2020 का निर्माण किया गया है। इस नवीन यू.एस.ओ.आर.-2020 में पेयजल योजनाओं के क्रियान्वयन के साथ-साथ संचालन एवं संधारण के कार्यों को भी सम्मिलित किया गया है, जो ग्रामीण जलप्रदाय योजनाओं के लिए आने वाले समय में बहुउपयोगी सिद्ध होगा। भारत सरकार द्वारा जल जीवन मिशन के अंतर्गत "हर घर नल" जिसमें राज्य शासन की भी बराबर की हिस्सेदारी है, जिसमें प्रत्येक ग्रामीण घर को 55 लीटर प्रति व्यक्ति प्रतिदिन पेयजल की उपलब्धता सुनिश्चित किया जाना है। इस योजना के साथ-साथ राज्य के अन्य सभी मदों की योजनाओं के क्रियान्वयन को ध्यान में रखते हुए अनेक कार्य जॉब वर्क के रूप में नवीन यू.एस.ओ.आर. में सम्मिलित किया गया है, जो मैदानी अमलो के लिए कारगर साबित होगा।

नवीन यू.एस.ओ.आर.-2020 के निर्माण में यू.एस.ओ.आर. समिति के अधिकारियों ने अत्यंत सीमित समय में अथक परिश्रम के साथ समय सीमा में इस कार्य को अमली जामा पहनाया है, मैं उन्हें बधाई सहित शुभकामनाएं प्रेषित करता हूँ।



(अविनाश चम्पावत)

कार्यालय प्रमुख अभियंता
लोक स्वास्थ्य यांत्रिकी विभाग
छत्तीसगढ़, अटल नगर, नवा रायपुर

क्रमांक 55 /स्था.शा./प्र.अ./लो.स्वा.यां.वि./2020

रायपुर, दिनांक 01/06/2020

कार्यालयीन आदेश

एतद द्वारा लोक स्वास्थ्य यांत्रिकी विभाग छत्तीसगढ़ में Unified Schedule of Rate for Water Supply Sewerage & Allied Works के नवीन एकीकृत दर को इस आदेश के जारी होने की तिथि 01 जून, 2020 से प्रभावशील किया जाता है। इस दर अनुसूची के प्रभावशील होने की तिथि 01 जून, 2020 से संबंधित कार्य हेतु विभाग में लागू पूर्व की दर अनुसूची वर्ष 2013 (समस्त संशोधनों सहित) अप्रभावशील माना जावेगा।

यह एकीकृत दर अनुसूची विभागीय वेबसाईट <https://phed.cg.gov.in> पर देखी जा सकती है। यह आदेश 01 जून, 2020 से प्रभावशील होगा।

(डॉ.एम.एल.अग्रवाल)

प्रमुख अभियंता

लोक स्वास्थ्य यांत्रिकी विभाग
छत्तीसगढ़ अटल नगर, नवा रायपुर

पृ0 क्रमांक 3070/तक.शा./प्र.अ./लो.स्वा.यां.वि./2020

रायपुर, दिनांक 01/06/2020

प्रतिलिपि :-

1. विशेष सहायक, माननीय मंत्रीजी, छत्तीसगढ़ शासन, लोक स्वास्थ्य यांत्रिकी विभाग, मंत्रालय महानदी भवन, अटल नगर, नवा रायपुर ।
2. उपसचिव, कार्यालय मुख्य सचिव की ओर अध्यक्ष एवं, एस.डब्ल्यू.एस.एम., (जे.जे.एम.) एवं मुख्य सचिव, छत्तीसगढ़ शासन की ओर अवगत कराने हेतु ।
3. अपर मुख्य सचिव वित्त विभाग, छत्तीसगढ़ शासन, मंत्रालय महानदी भवन, अटल नगर, नवा रायपुर ।
4. सचिव, छत्तीसगढ़ शासन, लोक स्वास्थ्य यांत्रिकी विभाग, मंत्रालय महानदी भवन, अटल नगर, नवा रायपुर ।
5. सचिव, नगरीय प्रशासन एवं विकास विभाग, छत्तीसगढ़ शासन, मंत्रालय महानदी भवन, अटल नगर, नवा रायपुर ।
6. महोलखाकार, छत्तीसगढ़ रायपुर ।
7. मुख्य तकनीकी परीक्षक, प्रथम तल, इन्द्रावती भवन, अटल नगर, नवा रायपुर ।
8. प्रमुख अभियंता, जल संसाधन विभाग/लोक निर्माण विभाग/ग्रामीण यांत्रिकी सेवा रायपुर ।
9. समस्त मुख्य अभियंता, लोक स्वास्थ्य यांत्रिकी विभाग परिक्षेत्र
10. समस्त अधीक्षण अभियंता, लोक स्वास्थ्य यांत्रिकी विभाग मंडल
11. समस्त कलेक्टर एवं अध्यक्ष, जिला जल एवं स्वच्छता समिति (जे.जे.एम.) जिला..... ।
12. समस्त कार्यपालन अभियंता, लोक स्वास्थ्य यांत्रिकी खंड..... ।
13. लेखा शाखा/तकनीकी शाखा/एम.आई.एस.शाखा, कार्यालय प्रमुख अभियंता, लोक स्वास्थ्य यांत्रिकी विभाग, छत्तीसगढ़ अटल नगर, नवा रायपुर ।
14. कार्यालयीन आदेश नस्ती।

संलग्न :- नवीन यू.एस.ओ.आर. की एक प्रति।

01/06/2020

प्रमुख अभियंता

लोक स्वास्थ्य यांत्रिकी विभाग
छत्तीसगढ़ अटल नगर, नवा रायपुर

CONTENTS

| CHAPTER No. | PARTICULARS | PAGES No. From -To |
|----------------|---|-----------------------|
| 1 | PREFACE | 1 - 1 |
| Part (A) | Water Supply & Sewerage Works | 2- 2 |
| 2 | General Notes | 3 -8 |
| I | Cast Iron Pipes &Specials With Socket &Spigot Joints (Lead Joint) | 9 - 28 |
| II | Cast Iron Tyton Pipes With Tyton Joints | 29 - 32 |
| III | Cast Iron Pipes & Specials With Flanged Joints | 33 - 50 |
| IV | Ductile Iron Pressure Pipes &Specials With Tyton Joints | 51 - 77 |
| V | Asbestos Cement Pressure Pipes & Cast Iron Fittings | 78- 87 |
| VI | Galvanised Iron Pipes, Gun Metal/ Brass Valves And Fittings | 88 - 106 |
| VII | Pvc Pipes, O-Pvc Pipes & Fittings | 107 - 113 |
| VIII | Cast Iron Valves | 114 - 120 |
| IX | HDPE Pipe, MDPE Pipe &Specials | 121 - 136 |
| X | Mild Steel Pipes And Specials | 137 - 147 |
| XI | Bar Wrapped Steel Cylinder Pipes (BWSC) | 148 - 160 |
| XII | Stone Ware Pipes For Sewers | 161 - 168 |
| XIII | Reinforced Cement Concrete Pipes | 169 - 178 |
| XIV | Double Wall Corrugated (Dwc) Pipes | 179 - 182 |
| XV | Surge Protection Valves | 183 -188 |
| XVI | Smooth Flow Pipes | 189 - 193 |
| XVII | Sewer Appurtenances | 194 - 209 |
| XVIII | Survey And Allied Civil Works | 210- 235 |
| XIX | General Miscellaneous | 236 - 256 |

| CHAPTER No. | PARTICULARS | PAGES No. From -To |
|--------------------|--|---------------------------|
| Part (B) | Intake Well, Water Treatment Plants, Elevated Service Reservoirs, Ground Service Reservoirs, Water Meters, Ancillary Items, Miscellaneous Items And Outdoors Transformers | 257-257 |
| XX | Intakewell Works | 258 - 267 |
| XXI | Water Treatment Plants | 268 -280 |
| XXII | Sewage Treatment Plants | 281 - 289 |
| XXIII | Rcc Elevated Service Reservoirs | 290-296 |
| XXIV | Ground Service Reservoirs | 297-301 |
| XXV | Water Meters | 302-306 |
| XXVI | Ancillary Items | 307 - 315 |
| Part-(C) | Electrical & Mechanical Works | 316 - 316 |
| XXVII | Technical Notes | 317 - 323 |
| XXVIII | Resistivity Survey | 324 - 325 |
| XXIX | Construction Of Ordinary Tube Well | 326 - 328 |
| XXX | Construction Of Gravel Packed Tube Well | 329 - 331 |
| XXXI | Installation Of Hand Pump, Construction Of Platform, Drain And Soakage Pit | 332 - 334 |
| XXXII | Development, Yield Test And Disinfection Of Tube Well | 335 - 336 |
| XXXIII | Odex Type Of Tube Well | 337 - 339 |
| XXXIV | Miscellaneous Item Of Tube Well | 340 - 354 |
| Annexure 1- | Issue Rates | 355 - 355 |
| Annexure 2- | Strata Chart Proforma | 356 - 356 |
| Annexure 3- | Resistivity Survey Report Proforma | 357 -358 |
| Annexure 4- | Yield Test Report Proforma | 359 - 360 |
| Part(D) | Drawings | 361 -381 |

PREFACE

The Unified Schedule of Rates for Water Supply & Sewerage Works were made applicable in Public Health Engineering Department for the entire state of Chhattisgarh as “Unified Schedule of Rates” which was enforced from 7th February 2013. As seven years have passed since the issue of this USOR and meanwhile the new taxation system in the form of Goods & Service Tax (GST) has also been enforced from 1st July 2017. Recently, GoI, Ministry of Jal Shakti, Department of Drinking Water and Sanitation has also launched Jal-Jeevan Mission with the theme of “Har Ghar Nal Se Jal” in which our state has a target of providing 41,32,535 functional household tap connections (FHTC) up to Sept., 2023. This has substantially effected the rates of all the items of the USOR. So, it was necessary to revise the USOR looking to the hike in the prices of materials and labour etc. involved in above works and segregate the GST portion to be paid separately over and above the USOR rates as per the prevailing government norms from time to time.

This USOR contains the rates of all the items without GST. No claims against GST shall be entertained at any level. GST shall be paid by the Agency/ Contractor directly to the concerning department. However, All the estimates based on this USOR will include GST, as an extra amount as per prevailing rates on the sum of the estimate to arrive at the gross amount. The probable amount of cost (PAC) put to tenders shall be exclusive of GST.

This Unified Schedule of Rates for all the works related to the Public Health Engineering Department have been revised. This new USOR also included- (i) E&M works of Mechanical wings and (ii) O&M of various schemes to facilitate the preparation of realistic estimates and bringing uniformity in the rates and specifications of various type of works to be executed by the Public Health Engineering Department in the State.

I extend my deepest sense of gratitude towards Shri Guru Rudra Kumar Hon’ble Minister, Govt. of CG, PHED and Shri Avinash Champawat, IAS, Secretary, Govt. of CG, PHED for their invaluable directions, supervision and perpetual encouragement during preparation of this USOR.

I express my sincere thanks to members of the new USOR committee- Shri A.K. Sahu, Chief Engineer; Shri Dharmendra Sahu, Joint-director (Finance); Shri Rajesh Gupta, Superintending Engineer; Shri R.K. Dewangan, Shri Samir Gaur, Shri Mohan Singh Thakur, Executive Engineer; and member-secretary of the committee- Ms Ashalata Gupta, Executive Engineer; Shri Budhad Deo, Assistant Engineer (E&M) and Shri Parate, Stenographer for their commendable efforts in preparing this schedule of rates.

This Unified Schedule of Rates (USOR) for the work of Water Supply, Sewerage and Allied works shall come in to force **from 01st June, 2020.**

(Dr. M.L. Agrawal)
Chairman New USOR Committee and
Engineer-in-Chief
Public Health Engineering Department
Chhattisgarh, Raipur

PART (A)

**WATER SUPPLY
&
SEWERAGE WORKS**

UNIFIED SCHEDULE OF RATES
GENERAL NOTES
WATER SUPPLY AND SEWERAGE WORKS

1. Definitions:-

The following terms and expressions wherever they appear in the schedule of rates shall have the meaning and implications assigned to them.

- (i) **Engineer in Charge:-**Engineer in Charge would refer to the Executive Engineer of Public Health Engineering Division in charge of work.
- (ii) **Diameter:-**Diameter of pipes, specials, valves etc. shall be the nominal internal diameter of the bore except for PVC, PVC-O and HDPE pipes for which the diameter of pipe will denote the outer nominal diameter of pipe. These would be as per IS codes.
- (iii) **Providing & Fixing:-** The provision of all materials and labour and the performance of all workmanship together with the use of all materials and labour, transport, tools, plants, appliances and all other provisions necessary for the proper execution of work as described in the concerned item of schedule of rates and the provision and uses of all coverings or casing etc. necessary to protect the work from inclement weather etc. and from damages from falling materials or other causes and all required safety arrangements.
- (iv) **Laying and Fixing only:-**As defined, for 'providing and fixing' except the provision of the materials (which will be supplied free of cost by the department for incorporation in the work) to be fixed or laid, but including taking supply of the articles from the Public Health Engineering Department stores and the provisions of materials necessary for the proper execution of the work as described in the item of schedule of rates which are subsidiary to, but are not supplied as part of the principal articles such as bolts, nuts, packing, jointing materials etc, and the like unless other-wise specifically excluded and mentioned in the tender documents.
This also include testing, closing, preparing, loading and returning empty cases, containers, bags & baggage of the articles provided by the Department if any, to the place of issue without any extra charges.
- (v) **Loading and unloading of pipe:-**During unloading, the pipe shall not be drawn on hard ground and shall be gently unloaded using proper supports without causing any damage to the pipe etc. Unloading of pipes on timber skids without steadying rope and thus allowing the pipe to bump against one another shall not be allowed and the contractor shall be responsible for any damage.
- (vi) **Best:-**With reference to quality of materials and workmanship the word 'Best' when used shall mean that in the opinion of the Engineer-in-Charge, there is no superior material or article or class of workmanship obtainable in the market.
- (vii) **(a) ISS:-**The Indian Standard Specifications as issued by the Bureau of Indian

Standards, New Delhi, wherever mentioned in this USOR shall be considered as current and duly updated.

- (viii) **(b) BSS:-**The British Standard Specifications as issued by the British Standard Institution, wherever mentioned in this USOR shall be considered as current and duly updated.
- (ix) **Complete:-**The provision of all such materials and labour and the performance of all such workmanship which may be necessary for the proper execution of the work in best workmanship manner but not particularly described in the items of schedule of rates due to their petty nature.

2. Rate for completed items include the cost of following:-

- (i) All material, labour, workmanship, templates, tools, hire and running charges of plants & machinery required to complete the work, unless specified otherwise.
- (ii) All lead & lift of materials required for execution of work inclusive of charges like duties, cess, tax, royalty etc.
- (iii) Provision for erection, removal of centring form works, scaffolding, benching, ladders and all other applications etc, required for execution of the work, unless otherwise specified.
- (iv) Provision for necessary covering to protect the work/structure from inclement weather etc. and damage arising from falling of materials or rains, fire etc shall be the responsibility of the contractor.
- (v) Curing wherever required including arrangement of water and also including its lead or lift whatsoever.
- (vi) The mode of measurements shall be as per provisions contained in the relevant chapters and in specifications/relevant IS codes.
- (vii) All materials shall conform to the relevant prevailing Indian Standard Specifications. All material before use in works shall require approval of the Engineer in charge, who will get them sampled, tested as per relevant IS code at contractor's cost and samples so approved shall be kept in the office of the concerned Engineer-in-charge till finalization of the work.
- (viii) Material obtained from excavation shall be the property of the Department.
- (x) Hard Rock available from excavation, shall be used for conversion into coarse aggregates or for other construction material and shall be issued to the contractor on the rate as decided by competent authority.

3. Cement:-

- (i) Where contract provides for cement to be arranged by the Contractor himself, only I.S.I. Marked cement for OPC (Ordinary Portland Cement) as per IS 269-1989 for 33 grade cement, IS 8112-1989 for 43 grade cement, IS 12269-2013 for 53 grade cement & IS: 455-1989 for PSC (Portland Slag Cement)

specifications shall be allowed to be used in the work subject to the prescribed tests.

- (ii) Make of cement shall be got approved by the Engineer-in-charge. The engineer in charge shall get cement tested as per relevant IS codes, at the cost of the contractor, before use in work.
- (iii) For pre-stressed concrete works where the strength of concrete required is more than M-30, then Ordinary Portland Cement (OPC) - 53 grade cement conforming to relevant IS code shall be used.
- (iv) In specific cases requiring higher grade of strength, use of OPC should be invariably ensured.
- (v) The arrangement for necessary equipment and testing shall have to be made by the contractor himself at site, as decided by the Engineer-in-Charge. All expenses shall be borne by the contractor.
- (vi) Any lot of cement brought to site by the contractor, would be permitted to be used in the work only after the satisfactory results of the tests, under the supervision of the Engineer-in- Charge or his authorised representative. The record of the test results shall be maintained in register mentioned in subsequent Para.

4. If any item of work is found not up to the prescribed standard but the Engineer-in-charge is of the opinion that the same is structurally adequate and can be accepted at a reduced rate, then in such case, the Engineer-in-charge shall submit proposal for the same, supported by an analysis in justification thereof, through proper channel to the Superintending Engineer of the Public Health Engineering Department to obtain his approval expeditiously (ordinarily within 15 days). The approved analysis along with orders of the Superintending Engineer should be appended to the final bill of the contractor.

5. Approval of materials

All materials shall be used strictly in accordance with the specifications and of the description and make as detailed in items of schedule of rate. The quantity of the various kinds of materials to be used in the works shall in all cases be determined by the Executive Engineer. All materials before use in the works shall require prior approval of the Engineer-in-charge. When materials are specified to comply with an I.S. or BIS. The contractor shall, if required, furnish the manufactures' certificate that the materials satisfy the requirement of the IS or BIS respectively.

6. Alternative

No alternative materials other than those specified in the agreement will generally be allowed to be used in the works except when their use becomes absolutely necessary in the interest of work on such grounds as non-availability in the market due to import restrictions or any other particular

reasons beyond control of the contractor. But in all such cases, the Executive Engineer after satisfying himself about the facts will permit in writing the use of such alternatives and will recommend suitable alternation in rates for such works to the competent authority. No permission for using such alternative material shall however be granted if so mentioned in the tender documents.

7. Laying

The approximate positions of all fittings shall generally be shown on the plans prepared for the purpose. But it will be the sole responsibility of the contractor to ascertain the work on the spot and the exact position where each fitting is to be fixed from the Engineer-in-Charge before carrying out the work. When the pipe is closed and trench gets flooded by rain, due care shall be taken to prevent the pipe from flooding.

8. Testing of materials

The contractor, on completion, or whenever required by the Engineer-in-Charge, shall prove all materials and pipes, fittings, joints and other accessories etc. to be clear, clean, perfect in working conditions and strong enough to withstand the test so specified here-in-under different items of the specifications. For this purpose the contractor at his own expense, shall provide all instruments and suitable appliances and carry out the necessary test before the Engineer-in-Charge or his representative to his entire satisfaction. The contractor shall rectify any defects as to the materials or workmanship, so noticed, and the defective portions re-tested at his expense. Till such time the test is completed an extra 03% of the bill amount shall be withheld from the contractor's running bill and same will be released only after testing, up to the entire satisfaction of the Engineer-in-Charge such material/works shall be replaced/redone if so required by Engineer-in-Charge.

9. Lead

Rates include all leads & lifts for the materials and no extra lead on account of shifting of materials from one place to another is payable, unless it is specifically mentioned in the contract agreement.

10. Specifications

Work shall be executed in accordance with the specifications given in this schedule and the specifications for works in vogue in PHED, Govt of CG, and the specifications attached with the 'Notice Inviting Tenders' and the "Contract Agreement". Latest CPHEEO manual, published by the Ministry of Urban Development, Govt. of India shall also be applicable. In case of any discrepancy, the specific provision in the 'Contract Agreement' will take precedence and the decision of the authority, sanctioning the tender, shall be binding and final. The materials to be used in works i.e. pipes; specials, valves

etc. are to be supplied by the departmental store, unless otherwise mentioned in the contract document. As such, specifications for the same are not given in this schedule of rates. In case any materials are required to be supplied by the contractor for any particular work, materials conforming to relevant I.S. Specification, B.S. specification, material of best quality available in the market shall only to be used after the approval of the Engineer in Charge.

11. Survey and Allied Civil Works

It shall be done as per specification given in chapter XVIII and standard IS codes for each work.

12. Safety

The contractor shall be fully and solely responsible for making all the safety arrangements pertaining to the work. The contractor shall be fully responsible and liable in all respects for any accidents and subsequent legal consequences.

13. Interpretation

The Engineer in Chief PHED, Chhattisgarh, Raipur shall be the sole deciding Authority as to the meaning, interpretation and implications of various provisions in this schedule of rates. His decision shall be final and binding on all concerned.

14. Award of Contract

The rates for various items of works given in this Unified Schedule of Rates are based on average current market rates of materials & labour for whole of the Chhattisgarh State. The market rates may vary from place to place in the State depending upon the local conditions. No contract should, therefore be awarded directly on the rates given in this Unified Schedule of Rates without inviting proper tenders.

15. Application of Rates for Departmental Work

The rates for various items of works given in this Unified Schedule of Rates includes for 10% contractor's profit, 1% T&P, 3% sundries, 1% water and 1 Labour welfare cess. If the work is carried out departmentally then the rates applicable for Departmental works shall be 10.35 % $[(100 \times 12) / 116]$ less than the rates of various items given in this Unified Schedule of Rates. The over all rate to carry out the work departmentally shall be decided by the Superintending Engineer of the circle based on prevailing rate in circle after deducting 10.35% from the rates. No work shall be done departmentally unless other wise permitted in writing by the competent authority as per manual provisions.

16. As per prevailing rules, excise duty exemption is not available. Therefore no

excise duty is considered while computing the rates. All the concerned officers shall be responsible to get all the prevailing exemptions in any tax or duty as per prevailing policy. The computation of rates for D.I. pipes, S.W. pipes, R.C.C. pipe, U.P.V.C. pipes of G.I. pipes are exclusive of excise duty and if any, excise duty exemption shall be obtained as per prevailing rules for these pipes then, this benefit shall be availed by the department.

17. All necessary permissions regarding road cutting, blasting, electricalline/pole shifting, road diversion/closer, under ground utility services shifting/closer disturbance, tree cutting etc. and all other permissions or licenses or permits etc. where ever applicable, such as from Labour dept., Mining dept., P&T dept., PWD, WRD, Electricity board/ company, District administration, Local Urban bodies etc. shall also be obtained by the contractor from the competent authority at his own cost. The contractor shall be fully responsible for any consequences for any lapse in this.
18. Capacity of ESR/GSR to be constructed shall be rounded out to nearest 5000 litres - always on higher side i.e. if required capacity is 1,23,000 litres, it shall be rounded to 1,25,000 litres Similarly, if required capacity is 6,24,080 litres, it shall be rounded to 6,25,000 litres.
19. Capacity of Unconventional/ Conventional Water Treatment Plants shall be rounded to nearest 0.5 MLD always on higher side i.e. if WTP of 2.37 MLD is required, it shall be rounded to 2.5 MLD. For WTP having capacity less than 0.5 MLD, package type W.T.P. should be considered.
20. **GST**
This USOR contains the rates of all the items without GST. No claims against GST shall be entertained at any level. GST shall be paid by the Agency/ Contractor directly to the concerning department. Howerer, All the estimates prepared on this USOR will include GST, as an extra amount as per prevailing rates on the sum of the estimate to arrive at the gross amount. The probable amount of cost (PAC) put to tenders shall be exclusive of GST.

CHAPTER – I

CAST IRON PIPES AND SPECIALS WITH SOCKET AND SPIGOT JOINTS (LEAD JOINTS)

Chapter – I

CAST IRON PIPES AND SPECIALS WITH SOCKET AND SPIGOT JOINTS (CLASS LA, A, B)

NOTES:

1. The C.I.pipe shall conform to IS:1536-1939
2. The C.I.fittings shall conform to IS -1538-1993 (Part I to XXIV).
3. The laying of C.I. pipes shall be done as per IS:3114:1994
4. The caulking lead shall conform to IS 782:1978
5. All measurements shall be of the finished work.
6. Work shall be executed in accordance with the relevant Indian Standard Specifications (Updated) and all the conditions of the agreement of the work.
7. **This USOR contains the rates of all the items without GST. No claims against GST shall be entertained at any level. GST shall be paid by the Agency/ Contractor directly to the concerning department. However, All the estimates prepared on this USOR will include GST, as an extra amount as per prevailing rates on the sum of the estimate to arrive at the gross amount.**

SOCKET & SPIGOT CAST IRON PIPES WITH LEAD JOINTS (CLASS LA, A and B)

| S.No. | Items | Unit | Rates in Rs. | | |
|-------|---|------|--------------|---------|---------|
| | | | Class LA | Class A | Class B |
| 1.1 | Providing, laying and jointing following socket and spigot cast iron (Spun) Pipes including testing of joints, cost of pipes and jointing materials etc. complete. | | | | |
| | 80mm Dia | RM | 1103 | 1199 | 1285 |
| | 100mm Dia | RM | 1367 | 1505 | 1625 |
| | 125mm Dia | RM | 1751 | 1911 | 2051 |
| | 150mm Dia | RM | 2182 | 2391 | 2582 |
| | 200mm Dia | RM | 3138 | 3404 | 3656 |
| | 250mm Dia | RM | 4154 | 4523 | 4827 |
| | 300mm Dia | RM | 5356 | 5856 | 6203 |
| | 350mm Dia | RM | 6627 | 7189 | 7769 |
| | 400mm Dia | RM | 8065 | 8814 | 9369 |
| | 50mm Dia | RM | 9726 | 10684 | 11268 |
| | 500mm Dia | RM | 11385 | 12403 | 13138 |
| | 600mm Dia | RM | 15173 | 16565 | 17577 |
| | 700mm Dia | RM | 19223 | 21003 | 22418 |
| | 750mm Dia | RM | 21132 | 23102 | 24761 |
| | 800mm Dia | RM | 29861 | 32835 | 35809 |

| S.No. | Items | Unit | Rates in Rs. | | |
|-------|--|------|-----------------|----------------|----------------|
| | 900mm Dia | RM | 35741 | 39327 | 42974 |
| | 1000mm Dia | RM | 42147 | 46440 | 50553 |
| 1.2 | Labour for laying in position following socket & spigot cast iron (Spun) pipes. | | Class LA | Class A | Class B |
| | 80mmDia | RM | 18 | 20 | 21 |
| | 100mm Dia | RM | 22 | 25 | 27 |
| | 125mm Dia | RM | 29 | 33 | 35 |
| | 150mm Dia | RM | 37 | 41 | 44 |
| | 200mm Dia | RM | 54 | 59 | 63 |
| | 250mm Dia | RM | 73 | 79 | 84 |
| | 300mm Dia | RM | 94 | 103 | 109 |
| | 350mm Dia | RM | 118 | 128 | 136 |
| | 400mm Dia | RM | 144 | 158 | 168 |
| | 450mm Dia | RM | 174 | 191 | 201 |
| | 500mm Dia | RM | 203 | 222 | 235 |
| | 600mm Dia | RM | 271 | 296 | 314 |
| | 700mm Dia | RM | 350 | 382 | 408 |
| | 750mm Dia | RM | 391 | 428 | 460 |
| | 800mm Dia | RM | 554 | 609 | 664 |
| | 900mm Dia | RM | 675 | 743 | 812 |
| | 1000mm Dia | RM | 812 | 895 | 974 |
| 1.3 | Providing lead caulked joints to following socket & spigot cast iron (spun) pipes and specials class 'LA' 'A' and 'B' including testing of the joints and cost of jointing materials (i.e. pig lead and spun yarn) etc. complete. | | | | |
| | 80mmDia | Each | 182 | 182 | 182 |
| | 100mm Dia | Each | 240 | 240 | 240 |
| | 125mm Dia | Each | 262 | 262 | 262 |
| | 150mm Dia | Each | 353 | 353 | 353 |
| | 200mm Dia | Each | 530 | 530 | 530 |
| | 250mm Dia | Each | 642 | 642 | 642 |
| | 300mm Dia | Each | 799 | 799 | 799 |
| | 350mm Dia | Each | 859 | 859 | 859 |
| | 400mm Dia | Each | 1016 | 1016 | 1016 |
| | 450mm Dia | Each | 1349 | 1349 | 1349 |
| | 500mm Dia | Each | 1557 | 1557 | 1557 |
| | 600mm Dia | Each | 1751 | 1751 | 1751 |
| | 700mm Dia | Each | 2056 | 2056 | 2056 |
| | 750mm Dia | Each | 2407 | 2407 | 2407 |
| | 800mm Dia | Each | 3042 | 3042 | 3042 |
| | 900mm Dia | Each | 3696 | 3696 | 3696 |

| S.No. | Items | Unit | Rates in Rs. | | |
|-------|---|------|--------------|---------------------|--------------------|
| | 1000mm Dia | Each | 4353 | 4353 | 4353 |
| 1.4 | Labour for providing lead caulked joints to following socket & spigot cast iron (spun) pipes and specials class 'LA' 'A' and 'B' including testing of joints but excluding cost of jointing materials (i.e. pig lead and spun yarn). | | | | |
| | 80mmDia | Each | 127 | 127 | 127 |
| | 100mm Dia | Each | 175 | 175 | 175 |
| | 125mm Dia | Each | 183 | 183 | 183 |
| | 150mm Dia | Each | 254 | 254 | 254 |
| | 200mm Dia | Each | 359 | 359 | 359 |
| | 250mm Dia | Each | 430 | 430 | 430 |
| | 300mm Dia | Each | 542 | 542 | 542 |
| | 350mm Dia | Each | 613 | 613 | 613 |
| | 400mm Dia | Each | 665 | 665 | 665 |
| | 450mm Dia | Each | 900 | 900 | 900 |
| | 500mm Dia | Each | 1076 | 1076 | 1076 |
| | 600mm Dia | Each | 1148 | 1148 | 1148 |
| | 700mm Dia | Each | 1356 | 1356 | 1356 |
| | 750mm Dia | Each | 1596 | 1596 | 1596 |
| | 800mm Dia | Each | 2153 | 2153 | 2153 |
| | 900mm Dia | Each | 2708 | 2708 | 2708 |
| | 1000mm Dia | Each | 3264 | 3264 | 3264 |
| 1.5 | Providing and laying in position following double socket cast iron 90° bend. | | | Medium Class | Heavy Class |
| | 80mmDia | Each | | 1417 | 1624 |
| | 100mm Dia | Each | | 2008 | 2159 |
| | 125mm Dia | Each | | 2597 | 2833 |
| | 150mm Dia | Each | | 3448 | 3713 |
| | 200mm Dia | Each | | 5282 | 5747 |
| | 250mm Dia | Each | | 7426 | 8140 |
| | 300mm Dia | Each | | 10078 | 11043 |
| | 350mm Dia | Each | | 13484 | 14805 |
| | 400mm Dia | Each | | 17226 | 18950 |
| | 450mm Dia | Each | | 21342 | 23666 |
| | 500mm Dia | Each | | 27000 | 29866 |
| | 600mm Dia | Each | | 38665 | 42981 |
| | 700mm Dia | Each | | 53698 | 59786 |
| | 750mm Dia | Each | | 62603 | 69815 |
| | 800mm Dia | Each | | 73344 | 81787 |

| S.No. | Items | Unit | Rates in Rs. | |
|-------|--|------|---------------------|--------------------|
| | 900mm Dia | Each | 96450 | 107821 |
| | 1000mm Dia | Each | 122958 | 137406 |
| 1.6 | Providing and laying in position following double socket cast iron 45° bend. | | Medium Class | Heavy Class |
| | 80mmDia | Each | 1417 | 1624 |
| | 100mm Dia | Each | 2008 | 2159 |
| | 125mm Dia | Each | 2527 | 2763 |
| | 150mm Dia | Each | 3308 | 3573 |
| | 200mm Dia | Each | 4932 | 5396 |
| | 250mm Dia | Each | 6866 | 7510 |
| | 300mm Dia | Each | 9239 | 10064 |
| | 350mm Dia | Each | 12110 | 13215 |
| | 400mm Dia | Each | 15274 | 16637 |
| | 450mm Dia | Each | 18739 | 20629 |
| | 500mm Dia | Each | 23313 | 25529 |
| | 600mm Dia | Each | 32592 | 35895 |
| | 700mm Dia | Each | 44370 | 48868 |
| | 750mm Dia | Each | 51251 | 56583 |
| | 800mm Dia | Each | 59751 | 65880 |
| | 900mm Dia | Each | 77144 | 85263 |
| | 1000mm Dia | Each | 97363 | 107617 |
| 1.7 | Providing and laying in position following double socket cast iron 22½° bend. | | Medium Class | Heavy Class |
| | 80mmDia | Each | 1208 | 1485 |
| | 100mm Dia | Each | 1798 | 1949 |
| | 125mm Dia | Each | 2247 | 2413 |
| | 150mm Dia | Each | 2958 | 3153 |
| | 200mm Dia | Each | 4442 | 4767 |
| | 250mm Dia | Each | 6097 | 6531 |
| | 300mm Dia | Each | 7980 | 8595 |
| | 350mm Dia | Each | 10302 | 11118 |
| | 400mm Dia | Each | 12888 | 13888 |
| | 450mm Dia | Each | 15630 | 16942 |
| | 500mm Dia | Each | 19336 | 20901 |
| | 600mm Dia | Each | 26591 | 28882 |
| | 700mm Dia | Each | 35766 | 38674 |
| | 750mm Dia | Each | 41274 | 44653 |
| | 800mm Dia | Each | 47604 | 51780 |
| | 900mm Dia | Each | 60803 | 66175 |

| S.No. | Items | Unit | Rates in Rs. | |
|--------------|---|-------------|---------------------|--------------------|
| | 1000mm Dia | Each | 76034 | 82744 |
| 1.8 | Providing and laying in position following double socket cast iron 11¼° bend. | | Medium Class | Heavy Class |
| | 80mmDia | Each | 1278 | 1414 |
| | 100mm Dia | Each | 1658 | 1809 |
| | 125mm Dia | Each | 2107 | 2273 |
| | 150mm Dia | Each | 2748 | 2944 |
| | 200mm Dia | Each | 4093 | 4417 |
| | 250mm Dia | Each | 5607 | 5972 |
| | 300mm Dia | Each | 7350 | 7825 |
| | 350mm Dia | Each | 9363 | 10034 |
| | 400mm Dia | Each | 11659 | 12442 |
| | 450mm Dia | Each | 14040 | 15134 |
| | 500mm Dia | Each | 17384 | 18659 |
| | 600mm Dia | Each | 23554 | 25338 |
| | 700mm Dia | Each | 31210 | 33612 |
| | 750mm Dia | Each | 35923 | 38724 |
| | 800mm Dia | Each | 41313 | 44695 |
| | 900mm Dia | Each | 52633 | 56703 |
| | 1000mm Dia | Each | 65333 | 70308 |
| 1.9 | Providing and laying in position following all socket cast iron Tees (all sizes in Milimeters) Body Cross Branch Dia | | Medium Class | Heavy Class |
| | 80x80 | Each | 1886 | 2024 |
| | 100x80 | Each | 2347 | 2385 |
| | 100x100 | Each | 2491 | 2645 |
| | 125x80 | Each | 2882 | 2963 |
| | 125x100 | Each | 3026 | 3222 |
| | 125x125 | Each | 3243 | 3483 |
| | 150x80 | Each | 3401 | 3612 |
| | 150x100 | Each | 3827 | 3872 |
| | 150x125 | Each | 3971 | 4132 |
| | 150x150 | Each | 4187 | 4530 |
| | 200x80 | Each | 5421 | 5893 |
| | 200x100 | Each | 5565 | 6038 |
| | 200x125 | Each | 5709 | 6182 |
| | 200x150 | Each | 5926 | 6399 |

| S.No. | Items | Unit | Rates in Rs. | |
|--------------|--------------|-------------|---------------------|-------|
| | 200x200 | Each | 6431 | 6904 |
| | 250x80 | Each | 7409 | 8067 |
| | 250x100 | Each | 7554 | 8212 |
| | 250x125 | Each | 7770 | 8427 |
| | 250x150 | Each | 7986 | 8644 |
| | 250x200 | Each | 8419 | 9077 |
| | 250x250 | Each | 8924 | 9654 |
| | 300x80 | Each | 9920 | 10835 |
| | 300x100 | Each | 9992 | 10907 |
| | 300x125 | Each | 10209 | 11124 |
| | 300x150 | Each | 10353 | 11268 |
| | 300x200 | Each | 10930 | 11846 |
| | 300x250 | Each | 11436 | 12422 |
| | 300x300 | Each | 12085 | 13072 |
| | 350x200 | Each | 13605 | 14852 |
| | 350x250 | Each | 14181 | 15429 |
| | 350x300 | Each | 14831 | 16079 |
| | 350x350 | Each | 15481 | 16800 |
| | 400x200 | Each | 16979 | 18555 |
| | 400x250 | Each | 17556 | 19133 |
| | 400x300 | Each | 18133 | 19783 |
| | 400x350 | Each | 18855 | 20505 |
| | 400x400 | Each | 19722 | 21370 |
| | 450x250 | Each | 21954 | 22572 |
| | 450x300 | Each | 22603 | 23536 |
| | 450x350 | Each | 23325 | 24378 |
| | 450x400 | Each | 24047 | 25412 |
| | 450x450 | Each | 24912 | 27016 |
| | 500x250 | Each | 26158 | 26973 |
| | 500x300 | Each | 26808 | 27937 |
| | 500x350 | Each | 27530 | 28779 |
| | 500x400 | Each | 28250 | 29885 |
| | 500x450 | Each | 29117 | 31418 |
| | 500x500 | Each | 30127 | 32917 |
| | 600x300 | Each | 37151 | 39194 |
| | 600x350 | Each | 37873 | 40036 |
| | 600x400 | Each | 38739 | 41215 |
| | 600x450 | Each | 39605 | 42819 |

| S.No. | Items | Unit | Rates in Rs. | |
|--------------|--------------|-------------|---------------------|--------|
| | 600x500 | Each | 40543 | 44174 |
| | 600x600 | Each | 42780 | 46944 |
| | 700x350 | Each | 51505 | 54324 |
| | 700x400 | Each | 52372 | 55575 |
| | 700x450 | Each | 53309 | 57251 |
| | 700x500 | Each | 54248 | 58607 |
| | 700x600 | Each | 56196 | 60871 |
| | 700x700 | Each | 58722 | 64150 |
| | 750x400 | Each | 60251 | 63729 |
| | 750x450 | Each | 61261 | 65406 |
| | 750x500 | Each | 62271 | 66905 |
| | 750x600 | Each | 64219 | 69242 |
| | 750x700 | Each | 66456 | 72088 |
| | 750x750 | Each | 68044 | 74449 |
| | 800x400 | Each | 69746 | 72894 |
| | 800x450 | Each | 70684 | 74570 |
| | 800x500 | Each | 71695 | 75997 |
| | 800x600 | Each | 73860 | 78551 |
| | 800x700 | Each | 76097 | 81469 |
| | 800x750 | Each | 77251 | 83397 |
| | 800x800 | Each | 78983 | 86472 |
| | 900x450 | Each | 90715 | 95641 |
| | 900x500 | Each | 91726 | 97069 |
| | 900x600 | Each | 94107 | 99983 |
| | 900x700 | Each | 96560 | 103046 |
| | 900x750 | Each | 97715 | 104974 |
| | 900x800 | Each | 99014 | 107472 |
| | 900x900 | Each | 102334 | 112242 |
| | 1000x500 | Each | 115227 | 122036 |
| | 1000x600 | Each | 117536 | 124807 |
| | 1000x700 | Each | 120423 | 128447 |
| | 1000x750 | Each | 121649 | 130447 |
| | 1000x800 | Each | 123020 | 133016 |
| | 1000x900 | Each | 125762 | 137066 |
| | 1000x1000 | Each | 129659 | 142349 |

| S.No. | Items | Unit | Rates in Rs. | | |
|--------------|---|-------------|---------------------|---------------------|--------------------|
| 1.10 | Providing and laying in position following all socketed cast iron crosses (all sizes in millimeter). | | | Medium Class | Heavy Class |
| | 80mm | Each | | 2327 | 2464 |
| | 100mm | Each | | 2987 | 3209 |
| | 125mm | Each | | 3926 | 4162 |
| | 150mm | Each | | 5058 | 5392 |
| | 200mm | Each | | 7662 | 8195 |
| | 250mm | Each | | 10644 | 11429 |
| | 300mm | Each | | 14347 | 15381 |
| 1.11 | Providing and laying in position following socket & spigot cast iron tapers (Reducer) (all sizes in mm). | | | Medium Class | Heavy Class |
| | 100x80 | Each | | 1481 | 1519 |
| | 125x80 | Each | | 1871 | 1880 |
| | 125x100 | Each | | 1943 | 2139 |
| | 150x80 | Each | | 2383 | 2653 |
| | 150x100 | Each | | 2456 | 2725 |
| | 150x125 | Each | | 2672 | 2761 |
| | 200x100 | Each | | 3545 | 3945 |
| | 200x125 | Each | | 3689 | 4090 |
| | 200x150 | Each | | 3905 | 4306 |
| | 250x125 | Each | | 4884 | 5325 |
| | 250x150 | Each | | 5028 | 5542 |
| | 250x200 | Each | | 5460 | 6046 |
| | 300x150 | Each | | 6673 | 7371 |
| | 300x200 | Each | | 7178 | 7948 |
| | 300x250 | Each | | 7683 | 8283 |
| | 350x200 | Each | | 8337 | 8563 |
| | 350x250 | Each | | 8914 | 9438 |
| | 350x300 | Each | | 9491 | 10474 |
| | 400x250 | Each | | 11134 | 11603 |
| | 400x300 | Each | | 11856 | 12711 |
| | 400x350 | Each | | 12577 | 13697 |
| | 450x350 | Each | | 14377 | 15069 |
| 450x400 | Each | | 15243 | 16391 | |
| 500x350 | Each | | 16560 | 16945 | |
| 500x400 | Each | | 17427 | 18268 | |

| S.No. | Items | Unit | Rates in Rs. | |
|--------------|---|-------------|---------------------|--------------------|
| | 500x450 | Each | 18364 | 20017 |
| | 600x400 | Each | 22647 | 23679 |
| | 600x450 | Each | 23658 | 25501 |
| | 600x500 | Each | 24740 | 27144 |
| | 700x500 | Each | 29640 | 31835 |
| | 700x600 | Each | 32094 | 35038 |
| | 750x600 | Each | 36293 | 39006 |
| | 750x700 | Each | 39251 | 43007 |
| 1.12 | Providing and laying in position including testing following Double Socket cast iron tapers (reducer) (all sizes in mm). | | Medium Class | Heavy Class |
| | 100x80 | Each | 1481 | 1663 |
| | 125x80 | Each | 1871 | 2313 |
| | 125x100 | Each | 1943 | 2645 |
| | 150x80 | Each | 2383 | 2942 |
| | 150x100 | Each | 2456 | 3158 |
| | 150x125 | Each | 2600 | 3266 |
| | 200x100 | Each | 3545 | 4162 |
| | 200x125 | Each | 3689 | 4450 |
| | 200x150 | Each | 1886 | 4739 |
| | 250x150 | Each | 5028 | 5758 |
| | 250x200 | Each | 5460 | 6479 |
| | 300x150 | Each | 6673 | 7011 |
| | 300x200 | Each | 7178 | 7659 |
| | 300x250 | Each | 7683 | 8139 |
| | 350x200 | Each | 8337 | 9502 |
| | 350x250 | Each | 8914 | 10736 |
| | 350x300 | Each | 9491 | 12133 |
| | 400x250 | Each | 11134 | 12036 |
| | 400x300 | Each | 11856 | 13433 |
| | 400x350 | Each | 12577 | 14780 |
| | 450x350 | Each | 14377 | 15790 |
| | 450x400 | Each | 15243 | 17401 |
| | 500x350 | Each | 16560 | 17739 |
| | 500x400 | Each | 17427 | 19422 |
| | 500x450 | Each | 18364 | 21171 |
| | 600x400 | Each | 22647 | 24401 |
| | 600x450 | Each | 23658 | 25068 |
| | 600x500 | Each | 24740 | 27072 |

| S.No. | Items | Unit | Rates in Rs. | |
|--------------|--|-------------|---------------------|--------------------|
| | 700x500 | Each | 29640 | 31113 |
| | 700x600 | Each | 32094 | 35038 |
| | 750x600 | Each | 36293 | 37419 |
| | 750x700 | Each | 39251 | 41781 |
| 1.13 | Providing and laying in position following cast iron collars. | | Medium Class | Heavy Class |
| | 80mm dia | Each | 1208 | 1344 |
| | 100mm dia | Each | 1518 | 1670 |
| | 125mm dia | Each | 1897 | 2063 |
| | 150mm dia | Each | 2469 | 2664 |
| | 200mm dia | Each | 3533 | 3858 |
| | 250mm dia | Each | 4697 | 5132 |
| | 300mm dia | Each | 6091 | 6565 |
| | 350mm dia | Each | 7627 | 8226 |
| | 400mm dia | Each | 9128 | 9984 |
| | 450mm dia | Each | 11365 | 12314 |
| | 500 mm dia | Each | 13480 | 14610 |
| | 600 mm dia | Each | 17625 | 19121 |
| | 700 mm dia | Each | 22752 | 24574 |
| | 750 mm dia | Each | 25873 | 27951 |
| | 800 mm dia | Each | 29745 | 32113 |
| | 900 mm dia | Each | 36943 | 39784 |
| | 1000mm dia | Each | 44943 | 48256 |
| 1.14 | Providing and laying in position following cast iron socket caps. | | | |
| | 80mm dia | Each | 298 | 387 |
| | 100mm dia | Each | 399 | 519 |
| | 125mm dia | Each | 428 | 556 |
| | 150mm dia | Each | 580 | 753 |
| | 200mm dia | Each | 874 | 1049 |
| | 250mm dia | Each | 1058 | 1271 |
| | 300mm dia | Each | 1333 | 1599 |
| | 350mm dia | Each | 1409 | 1691 |
| | 400mm dia | Each | 1681 | 2017 |
| | 450mm dia | Each | 2182 | 2400 |
| | 500 mm dia | Each | 2561 | 2818 |
| | 600 mm dia | Each | 2802 | 3083 |
| | 700 mm dia | Each | 3302 | 3632 |
| | 750 mm dia | Each | 3892 | 4282 |
| | 800 mm dia | Each | 5089 | 5497 |
| | 900 mm dia | Each | 6286 | 6789 |
| | 1000 mm dia | Each | 7490 | 8089 |

| S.No. | Items | Unit | Rates in Rs. | | |
|--------------|---|-------------|---------------------|---------------------|--------------------|
| 1.15 | Providing and laying in position following cast iron plugs. | | | Medium Class | Heavy Class |
| | 80mm dia | Each | | 438 | 574 |
| | 100mm dia | Each | | 609 | 760 |
| | 125mm dia | Each | | 778 | 944 |
| | 150mm dia | Each | | 1139 | 1334 |
| | 200mm dia | Each | | 1784 | 2039 |
| | 250mm dia | Each | | 2459 | 2823 |
| | 300mm dia | Each | | 3292 | 3697 |
| | 350mm dia | Each | | 4157 | 4683 |
| | 400mm dia | Each | | 5369 | 5935 |
| | 450mm dia | Each | | 6882 | 7687 |
| | 500 mm dia | Each | | 8418 | 9332 |
| | 600 mm dia | Each | | 11480 | 12685 |
| | 700 mm dia | Each | | 15666 | 17127 |
| | 750 mm dia | Each | | 18425 | 20069 |
| | 800 mm dia | Each | | 22081 | 23871 |
| 900 mm dia | Each | | 28483 | 30601 | |
| 1000 mm dia | Each | | 35977 | 38422 | |
| 1.16 | Providing and laying in position following sizes of socket & spigot or all socketed cast iron specials class MEDIUM or HEAVY which does not appear in above items of schedule. | | | Medium Class | Heavy Class |
| | 80mm to 300mm Dia | Kg | | 88 | 88 |
| | Above 300mm Dia | Kg | | 85 | 85 |
| 1.17 | Labour for laying in position following double socket cast iron 45° bends. | | | Medium Class | Heavy Class |
| | 80mm dia | Each | | 35 | 39 |
| | 100mm dia | Each | | 50 | 52 |
| | 125mm dia | Each | | 64 | 69 |
| | 150mm dia | Each | | 83 | 88 |
| | 200mm dia | Each | | 124 | 133 |
| | 250mm dia | Each | | 178 | 191 |
| | 300mm dia | Each | | 242 | 259 |
| | 350mm dia | Each | | 317 | 341 |
| | 400mm dia | Each | | 404 | 433 |
| | 450mm dia | Each | | 491 | 532 |
| | 500 mm dia | Each | | 616 | 665 |
| | 600 mm dia | Each | | 884 | 961 |

| S.No. | Items | Unit | Rates in Rs. | |
|--------------|--|-------------|---------------------|--------------------|
| | 700 mm dia | Each | 1218 | 1328 |
| | 750 mm dia | Each | 1405 | 1536 |
| | 800 mm dia | Each | 1622 | 1774 |
| | 900 mm dia | Each | 2103 | 2310 |
| | 1000mm dia | Each | 2667 | 2934 |
| 1.18 | Labour for laying in position following double socket cast Iron 90° bends | | Medium Class | Heavy Class |
| | 80mm dia | Each | 35 | 39 |
| | 100mm dia | Each | 50 | 52 |
| | 125mm dia | Each | 66 | 71 |
| | 150mm dia | Each | 88 | 93 |
| | 200mm dia | Each | 135 | 143 |
| | 250mm dia | Each | 195 | 210 |
| | 300mm dia | Each | 268 | 290 |
| | 350mm dia | Each | 358 | 388 |
| | 400mm dia | Each | 462 | 502 |
| | 450mm dia | Each | 568 | 622 |
| | 500 mm dia | Each | 725 | 794 |
| | 600 mm dia | Each | 1065 | 1171 |
| | 700 mm dia | Each | 1496 | 1652 |
| | 750 mm dia | Each | 1742 | 1929 |
| | 800 mm dia | Each | 2025 | 2246 |
| | 900 mm dia | Each | 2675 | 2980 |
| | 1000mm dia | Each | 3427 | 3819 |
| 1.19 | Labour for laying in position following double socket cast iron 22½° bends. | | Medium Class | Heavy Class |
| | 80mm dia | Each | 27 | 35 |
| | 100mm dia | Each | 43 | 45 |
| | 125mm dia | Each | 56 | 58 |
| | 150mm dia | Each | 73 | 75 |
| | 200mm dia | Each | 110 | 114 |
| | 250mm dia | Each | 155 | 161 |
| | 300mm dia | Each | 203 | 215 |
| | 350mm dia | Each | 264 | 279 |
| | 400mm dia | Each | 332 | 352 |
| | 450mm dia | Each | 399 | 423 |
| | 500 mm dia | Each | 498 | 528 |
| | 600 mm dia | Each | 706 | 753 |
| | 700 mm dia | Each | 963 | 1026 |
| | 750 mm dia | Each | 1109 | 1183 |
| | 800 mm dia | Each | 1262 | 1356 |

| S.No. | Items | Unit | Rates in Rs. | |
|-------|--|------|---------------------|--------------------|
| | 900 mm dia | Each | 1618 | 1744 |
| | 1000mm dia | Each | 2034 | 2197 |
| 1.20 | Labour for laying in position following double socket castiron 11¼ ° bends. | | Medium Class | Heavy Class |
| | 80mm dia | Each | 31 | 33 |
| | 100mm dia | Each | 39 | 41 |
| | 125mm dia | Each | 52 | 54 |
| | 150mm dia | Each | 66 | 69 |
| | 200mm dia | Each | 99 | 103 |
| | 250mm dia | Each | 139 | 143 |
| | 300mm dia | Each | 184 | 191 |
| | 350mm dia | Each | 236 | 247 |
| | 400mm dia | Each | 296 | 309 |
| | 450mm dia | Each | 352 | 369 |
| | 500 mm dia | Each | 440 | 462 |
| | 600 mm dia | Each | 616 | 648 |
| | 700 mm dia | Each | 828 | 875 |
| | 750 mm dia | Each | 951 | 1007 |
| | 800 mm dia | Each | 1075 | 1146 |
| | 900 mm dia | Each | 1376 | 1463 |
| | 1000mm dia | Each | 1716 | 1828 |
| 1.21 | Labour for laying in position including testing following all socket cast iron, tees (all Sizes in mm). | | Medium Class | Heavy Class |
| | 80x80 | Each | 47 | 50 |
| | 100x80 | Each | 58 | 60 |
| | 100x100 | Each | 62 | 64 |
| | 125x80 | Each | 73 | 77 |
| | 125x100 | Each | 77 | 81 |
| | 125x125 | Each | 83 | 88 |
| | 150x80 | Each | 93 | 97 |
| | 150x100 | Each | 97 | 101 |
| | 150x125 | Each | 101 | 108 |
| | 150x150 | Each | 108 | 114 |
| | 200x80 | Each | 135 | 143 |
| | 200x100 | Each | 139 | 148 |
| | 200x125 | Each | 143 | 153 |
| | 200x150 | Each | 150 | 159 |
| | 200x200 | Each | 165 | 174 |
| | 250x80 | Each | 189 | 201 |
| | 250x100 | Each | 193 | 206 |

| S.No. | Items | Unit | Rates in Rs. | |
|--------------|--------------|-------------|---------------------|------|
| | 250x125 | Each | 199 | 213 |
| | 250x150 | Each | 206 | 219 |
| | 250x200 | Each | 219 | 232 |
| | 250x250 | Each | 234 | 249 |
| | 300x80 | Each | 255 | 275 |
| | 300x100 | Each | 257 | 277 |
| | 300x125 | Each | 264 | 284 |
| | 300x150 | Each | 268 | 288 |
| | 300x200 | Each | 286 | 305 |
| | 300x250 | Each | 300 | 322 |
| | 300x300 | Each | 319 | 341 |
| | 350x200 | Each | 363 | 390 |
| | 350x250 | Each | 379 | 408 |
| | 350x300 | Each | 399 | 427 |
| | 350x350 | Each | 418 | 448 |
| | 400x200 | Each | 455 | 491 |
| | 400x250 | Each | 472 | 508 |
| | 400x300 | Each | 489 | 528 |
| | 400x350 | Each | 510 | 549 |
| | 400x400 | Each | 537 | 574 |
| | 450x250 | Each | 588 | 632 |
| | 450x300 | Each | 607 | 652 |
| | 450x350 | Each | 628 | 674 |
| | 450x400 | Each | 650 | 695 |
| | 450x450 | Each | 676 | 723 |
| | 500x250 | Each | 702 | 764 |
| | 500x300 | Each | 721 | 783 |
| | 500x350 | Each | 742 | 804 |
| | 500x400 | Each | 764 | 828 |
| | 500x450 | Each | 789 | 854 |
| | 500x500 | Each | 820 | 886 |
| | 600x300 | Each | 1021 | 1117 |
| | 600x350 | Each | 1042 | 1139 |
| | 600x400 | Each | 1069 | 1165 |
| | 600x450 | Each | 1094 | 1193 |
| | 600x500 | Each | 1123 | 1221 |
| | 600x600 | Each | 1189 | 1291 |

| S.No. | Items | Unit | Rates in Rs. | |
|--------------|---|-------------|---------------------|--------------------|
| | 700x350 | Each | 1433 | 1564 |
| | 700x400 | Each | 1459 | 1592 |
| | 700x450 | Each | 1487 | 1622 |
| | 700x500 | Each | 1515 | 1650 |
| | 700x600 | Each | 1573 | 1705 |
| | 700x700 | Each | 1647 | 1785 |
| | 750x400 | Each | 1676 | 1834 |
| | 750x450 | Each | 1705 | 1865 |
| | 750x500 | Each | 1736 | 1896 |
| | 750x600 | Each | 1794 | 1954 |
| | 750x700 | Each | 1860 | 2021 |
| | 750x750 | Each | 1907 | 2070 |
| | 800x400 | Each | 1923 | 2107 |
| | 800x450 | Each | 1950 | 2137 |
| | 800x500 | Each | 1981 | 2167 |
| | 800x600 | Each | 2045 | 2231 |
| | 800x700 | Each | 2111 | 2300 |
| | 800x750 | Each | 2145 | 2337 |
| | 800x800 | Each | 2197 | 2390 |
| | 900x450 | Each | 2510 | 2764 |
| | 900x500 | Each | 2540 | 2793 |
| | 900x600 | Each | 2611 | 2868 |
| | 900x700 | Each | 2684 | 2942 |
| | 900x750 | Each | 2718 | 2978 |
| | 900x800 | Each | 2757 | 3015 |
| | 900x900 | Each | 2855 | 3117 |
| | 1000x500 | Each | 3203 | 3535 |
| | 1000x600 | Each | 3272 | 3607 |
| | 1000x700 | Each | 3357 | 3697 |
| | 1000x750 | Each | 3394 | 3736 |
| | 1000x800 | Each | 3435 | 3773 |
| | 1000x900 | Each | 3516 | 3856 |
| | 1000x1000 | Each | 3632 | 3974 |
| 1.22 | Labour for laying in position following all socket cast iron crosses. (all sizes in mm). | | Medium Class | Heavy Class |
| | 80mm dia | Each | 62 | 64 |

| S.No. | Items | Unit | Rates in Rs. | |
|--------------|--|-------------|---------------------|--------------------|
| | 100mm dia | Each | 79 | 83 |
| | 125mm dia | Each | 108 | 112 |
| | 150mm dia | Each | 137 | 143 |
| | 200mm dia | Each | 208 | 219 |
| | 250mm dia | Each | 294 | 311 |
| | 300mm dia | Each | 399 | 423 |
| 1.23 | Labour for laying in position including testing following socket and spigot cast iron tapers, (reducer) (all Sizes in mm) | | Medium Class | Heavy Class |
| | 100x80 | Each | 33 | 35 |
| | 125x80 | Each | 43 | 45 |
| | 125x100 | Each | 45 | 50 |
| | 150x80 | Each | 54 | 58 |
| | 150x100 | Each | 56 | 60 |
| | 150x125 | Each | 62 | 66 |
| | 200x100 | Each | 79 | 85 |
| | 200x125 | Each | 83 | 90 |
| | 200x150 | Each | 90 | 97 |
| | 250x125 | Each | 114 | 120 |
| | 250x150 | Each | 118 | 126 |
| | 250x200 | Each | 131 | 141 |
| | 300x150 | Each | 159 | 172 |
| | 300x200 | Each | 174 | 189 |
| | 300x250 | Each | 189 | 208 |
| | 350x200 | Each | 206 | 223 |
| | 350x250 | Each | 223 | 242 |
| | 350x300 | Each | 240 | 264 |
| | 400x250 | Each | 281 | 307 |
| | 400x300 | Each | 303 | 330 |
| | 400x350 | Each | 324 | 356 |
| | 450x350 | Each | 363 | 397 |
| | 450x400 | Each | 388 | 427 |
| | 500x350 | Each | 416 | 452 |
| | 500x400 | Each | 442 | 483 |
| | 500x450 | Each | 470 | 514 |
| | 600x400 | Each | 590 | 644 |
| | 600x450 | Each | 620 | 678 |
| | 600x500 | Each | 652 | 715 |

| S.No. | Items | Unit | Rates in Rs. | |
|--------------|--|-------------|---------------------|--------------------|
| | 700x500 | Each | 783 | 854 |
| | 700x600 | Each | 856 | 937 |
| | 750x600 | Each | 963 | 1055 |
| | 750x700 | Each | 1051 | 1156 |
| 1.24 | Labour for laying in position including testing following Double Socket cast iron taper (reducer) (all sizes in mm). | | Medium Class | Heavy Class |
| | 100x80 | Each | 33 | 39 |
| | 125x80 | Each | 43 | 58 |
| | 125x100 | Each | 45 | 64 |
| | 150x80 | Each | 54 | 66 |
| | 150x100 | Each | 56 | 73 |
| | 150x125 | Each | 60 | 81 |
| | 200x100 | Each | 79 | 93 |
| | 200x125 | Each | 83 | 101 |
| | 200x150 | Each | 90 | 110 |
| | 250x150 | Each | 118 | 133 |
| | 250x200 | Each | 131 | 155 |
| | 300x150 | Each | 159 | 161 |
| | 300x200 | Each | 174 | 180 |
| | 300x250 | Each | 189 | 203 |
| | 350x200 | Each | 206 | 251 |
| | 350x250 | Each | 223 | 281 |
| | 350x300 | Each | 240 | 313 |
| | 400x250 | Each | 281 | 319 |
| | 400x300 | Each | 303 | 352 |
| | 400x350 | Each | 324 | 388 |
| | 450x350 | Each | 363 | 418 |
| | 450x400 | Each | 388 | 457 |
| | 500x350 | Each | 416 | 476 |
| | 500x400 | Each | 442 | 518 |
| | 500x450 | Each | 470 | 549 |
| | 600x400 | Each | 590 | 665 |
| | 600x450 | Each | 620 | 665 |
| | 600x500 | Each | 652 | 713 |
| | 700x500 | Each | 783 | 833 |
| | 700x600 | Each | 856 | 937 |
| | 750x600 | Each | 963 | 1009 |
| | 750x700 | Each | 1051 | 1119 |

| S.No. | Items | Unit | Rates in Rs. | | |
|--------------|---|-------------|---------------------|---------------------|--------------------|
| 1.25 | Labour for laying in position including testing following cast Iron Collars. | | | Medium Class | Heavy Class |
| | 80 mm Dia | Each | | 27 | 31 |
| | 100 mm Dia | Each | | 35 | 37 |
| | 125 mm Dia | Each | | 45 | 47 |
| | 150 mm Dia | Each | | 58 | 60 |
| | 200 mm Dia | Each | | 81 | 85 |
| | 250 mm Dia | Each | | 112 | 118 |
| | 300 mm Dia | Each | | 145 | 153 |
| | 350 mm Dia | Each | | 184 | 193 |
| | 400 mm Dia | Each | | 221 | 236 |
| | 450 mm Dia | Each | | 272 | 286 |
| | 500 mm Dia | Each | | 324 | 341 |
| | 600 mm Dia | Each | | 440 | 464 |
| | 700 mm Dia | Each | | 578 | 607 |
| | 750 mm Dia | Each | | 652 | 686 |
| 800 mm Dia | Each | | 732 | 773 | |
| 900 mm Dia | Each | | 910 | 961 | |
| 1000 mm Dia | Each | | 1111 | 1173 | |
| 1.26 | Labour for laying in position following socketed cast iron caps. | | | Medium Class | Heavy Class |
| | 80 mm Dia | Each | | 10 | 15 |
| | 100 mm Dia | Each | | 13 | 19 |
| | 125 mm Dia | Each | | 18 | 25 |
| | 150 mm Dia | Each | | 22 | 33 |
| | 200 mm Dia | Each | | 36 | 52 |
| | 250 mm Dia | Each | | 51 | 73 |
| | 300 mm Dia | Each | | 69 | 99 |
| | 350 mm Dia | Each | | 92 | 131 |
| | 400 mm Dia | Each | | 116 | 165 |
| | 450 mm Dia | Each | | 145 | 208 |
| | 500 mm Dia | Each | | 177 | 253 |
| | 600 mm Dia | Each | | 257 | 367 |
| | 700 mm Dia | Each | | 353 | 504 |
| | 750 mm Dia | Each | | 409 | 584 |
| 800 mm Dia | Each | | 472 | 674 | |
| 900 mm Dia | Each | | 608 | 869 | |
| 1000 mm Dia | Each | | 772 | 1103 | |

| S.No. | Items | Unit | Rates in Rs. | | |
|--------------|---|-------------|---------------------|---------------------|--------------------|
| 1.27 | Labour for laying in position including testing following cast iron plugs. | | | Medium Class | Heavy Class |
| | 80 mm Dia | Each | | 4 | 6 |
| | 100 mm Dia | Each | | 6 | 8 |
| | 125 mm Dia | Each | | 11 | 13 |
| | 150 mm Dia | Each | | 17 | 19 |
| | 200 mm Dia | Each | | 27 | 31 |
| | 250 mm Dia | Each | | 43 | 47 |
| | 300 mm Dia | Each | | 60 | 64 |
| | 350 mm Dia | Each | | 81 | 88 |
| | 400 mm Dia | Each | | 110 | 116 |
| | 450 mm Dia | Each | | 139 | 148 |
| | 500 mm Dia | Each | | 174 | 184 |
| | 600 mm Dia | Each | | 257 | 272 |
| | 700 mm Dia | Each | | 367 | 386 |
| | 750 mm Dia | Each | | 431 | 452 |
| | 800 mm Dia | Each | | 504 | 528 |
| 900 mm Dia | Each | | 659 | 688 | |
| 1000 mm Dia | Each | | 845 | 882 | |
| 1.28 | Labour for laying in position following sizes of socket & spigot or all socketed cast iron standard specials class 'MEDIUM' or 'HEAVY' Which do not appear in above items of the schedule. | | | Medium Class | Heavy Class |
| | 80 mm to 750 mm Dia | Kg | | 2 | 2 |

CHAPTER – II

**CAST IRON TYTON PIPES
WITH TYTON JOINTS**

Chapter – II
CAST IRON TYTON PIPES WITH TYTON JOINTS (CLASS LA, A, B)

NOTES:

1. The C.I. pipe shall conform to IS:1536-2001
2. The C.I. fittings shall conform to IS -1538-1993 (Part I toXXIV).
3. The laying of C.I. pipes shall be done as per IS:3114:1994
4. The caulking lead shall conform to IS 782:1978
5. All measurements shall be of the finishedwork.
6. Work shall be executed in accordance with the relevant Indian Standard Specifications (Updated) and all the conditions of the agreement of thework.
7. The rubber sealing rings for jointing of pipe line shall be conforming to IS 5382:1985
8. **This USOR contains the rates of all the items without GST. No claims against GST shall be entertained at any level. GST shall be paid by the Agency/ Contractor directly to the concerning department. Howerer, All the estimates prepared on this USOR will include GST, as an extra amount as per prevailing rates on the sum of the estimate to arrive at the gross amount.**

SOCKET AND SPIGOT CAST IRON PIPES WITH TYTON JOINTS
(CLASS LA, A, AND B)

| S.No. | Items | Unit | Rates in Rs. | | |
|-------|---|-------|-----------------|----------------|----------------|
| | | | Class LA | Class A | Class B |
| 2.1 | Providing, laying and jointing following cast iron tyton pipes with tyton joints including testing of joints, cost of pipes and jointing materials etc complete. | | | | |
| | | | Class LA | Class A | Class B |
| | 80mm Dia | Meter | 1197 | 1225 | 1315 |
| | 100mm Dia | Meter | 1472 | 1538 | 1661 |
| | 125mm Dia | Meter | 1870 | 1953 | 2098 |
| | 150mm Dia | Meter | 2319 | 2445 | 2640 |
| | 200mm Dia | Meter | 3357 | 3481 | 3740 |
| | 250mm Dia | Meter | 4420 | 4626 | 4939 |
| | 300mm Dia | Meter | 5697 | 5990 | 6348 |
| | 350mm Dia | Meter | 7023 | 7356 | 7373 |
| | 400mm Dia | Meter | 8698 | 9018 | 9589 |
| | 450mm Dia | Meter | 10456 | 10930 | 11535 |
| | 500mm Dia | Meter | 12143 | 12691 | 13448 |
| | 600mm Dia | Meter | 16119 | 16948 | 17992 |
| | 700mm Dia | Meter | 20524 | 21494 | 22951 |
| | 750mm Dia | Meter | 22559 | 23649 | 25354 |
| | 800mm Dia | Meter | 31433 | 33608 | 36656 |
| | 900mm Dia | Meter | 37624 | 40263 | 44002 |

| S.No. | Items | Unit | Rates in Rs. | | |
|-------|--|-------|-----------------|-----------------|----------------|
| | 1000mm Dia | Meter | 44307 | 47556 | 51778 |
| 2.2 | Labour for laying in position including testing following cast iron tyton pipes. | | Class LA | Class- A | Class-B |
| | 80mm Dia | Meter | 18 | 20 | 21 |
| | 100mm Dia | Meter | 22 | 25 | 27 |
| | 125mm Dia | Meter | 29 | 33 | 35 |
| | 150mm Dia | Meter | 37 | 41 | 44 |
| | 200mm Dia | Meter | 54 | 59 | 63 |
| | 250mm Dia | Meter | 73 | 79 | 84 |
| | 300mm Dia | Meter | 94 | 103 | 109 |
| | 350mm Dia | Meter | 118 | 128 | 136 |
| | 400mm Dia | Meter | 144 | 158 | 168 |
| | 450mm Dia | Meter | 174 | 191 | 201 |
| | 500mm Dia | Meter | 203 | 222 | 235 |
| | 600mm Dia | Meter | 271 | 296 | 314 |
| | 700mm Dia | Meter | 350 | 382 | 408 |
| | 750mm Dia | Meter | 391 | 428 | 460 |
| | 800mm Dia | Meter | 554 | 609 | 664 |
| | 900mm Dia | Meter | 675 | 743 | 812 |
| | 1000mm Dia | Meter | 812 | 895 | 974 |
| 2.3 | Providing tyton joints to following tyton pipes of class 'LA' 'A' and 'B' including testing of joints and cost of jointing materials (i.e. Rubber Gasket and Soap solution etc.). | | | | |
| | 80mm Dia | Each | | | 84 |
| | 100mm Dia | Each | | | 94 |
| | 125mm Dia | Each | | | 105 |
| | 150mm Dia | Each | | | 119 |
| | 200mm Dia | Each | | | 194 |
| | 250mm Dia | Each | | | 232 |
| | 300mm Dia | Each | | | 297 |
| | 350mm Dia | Each | | | 341 |
| | 400mm Dia | Each | | | 565 |
| | 450mm Dia | Each | | | 651 |
| | 500mm Dia | Each | | | 663 |
| | 600mm Dia | Each | | | 822 |
| | 700mm Dia | Each | | | 1142 |
| | 750mm Dia | Each | | | 1254 |
| | 800mm Dia | Each | | | 1328 |
| | 900mm Dia | Each | | | 1592 |
| | 1000mm Dia | Each | | | 1818 |

| S.No. | Items | Unit | Rates in Rs. | | |
|--------------|--|-------------|---------------------|--|-----|
| 2.4 | Labour for providing tyton joints to following tyton pipes class 'LA' 'A'and 'B' including testing of joints but excluding cost of Rubber Gasket. | | | | |
| | 80mmDia | Each | | | 56 |
| | 100mm Dia | Each | | | 59 |
| | 125mm Dia | Each | | | 62 |
| | 150mm Dia | Each | | | 66 |
| | 200mm Dia | Each | | | 69 |
| | 250mm Dia | Each | | | 83 |
| | 300mm Dia | Each | | | 89 |
| | 350mm Dia | Each | | | 104 |
| | 400mm Dia | Each | | | 134 |
| | 450mm Dia | Each | | | 148 |
| | 500mm Dia | Each | | | 159 |
| | 600mm Dia | Each | | | 193 |
| | 700mm Dia | Each | | | 226 |
| | 750mm Dia | Each | | | 236 |
| | 800mm Dia | Each | | | 250 |
| | 900mm Dia | Each | | | 294 |
| | 1000mm Dia | Each | | | 315 |

CHAPTER – III

CAST IRON PIPES AND SPECIALS WITH FLANGED JOINTS

Chapter – III
CAST IRON PIPES AND SPECIALS WITH FLANGED JOINTS

NOTES:

1. The Horizontal C.I. double flanged pipe shall conform to IS:7181-1986
2. The C.I. fittings shall conform to IS -1538-1993 (Part I toXXIV).
3. The laying of C.I. pipes shall be done as per IS:3114:1994
4. All measurements shall be of the finishedwork.
5. Work shall be executed in accordance with the relevant Indian Standard Specifications (Updated) and all the conditions of the agreement of thework.
6. **This USOR contains the rates of all the items without GST. No claims against GST shall be entertained at any level. GST shall be paid by the Agency/ Contractor directly to the concerning department. Howerer, All the estimates prepared on this USOR will include GST, as an extra amount as per prevailing rates on the sum of the estimate to arrive at the gross amount.**

CAST IRON PIPES AND SPECIALS WITH FLANGED JOINTS (CLASS A, B)

| S.No. | ITEMS | Unit | Rates in Rs. | |
|-----------|--|-------|--------------|--|
| 3.1 | Providing, fixing and testing following double flanged cast iron(horizontal cast) pipe per IS :7181of One Meter length. | | | |
| | 80mm Dia | Each | 1701 | |
| | 100mm Dia | Each | 2176 | |
| | 125mm Dia | Each | 2651 | |
| | 150mm Dia | Each | 3270 | |
| | 200mm Dia | Each | 4447 | |
| | 250mm Dia | Each | 5939 | |
| | 300mm Dia | Each | 7492 | |
| | 350mm Dia | Each | 9289 | |
| | 400mm Dia | Each | 11606 | |
| | 450mm Dia | Each | 14060 | |
| | 500mm Dia | Each | 16258 | |
| | 600mm Dia | Each | 21515 | |
| | 700mm Dia | Each | 27496 | |
| 750mm Dia | Each | 29941 | | |
| 3.2 | Labour only for fixing including testing following double flanged cast iron (horizontal cast) pipe per IS : 7181 of One Meter length. | | | |
| | 80mm Dia | Each | 130 | |
| | 100mm Dia | Each | 141 | |
| | 125mm Dia | Each | 155 | |
| | 150mm Dia | Each | 169 | |

| S.No. | ITEMS | Unit | Rates in Rs. | |
|-------|---|------|--------------|--|
| | 200mm Dia | Each | 192 | |
| | 250mm Dia | Each | 240 | |
| | 300mm Dia | Each | 274 | |
| | 350mm Dia | Each | 326 | |
| | 400mm Dia | Each | 413 | |
| | 450mm Dia | Each | 471 | |
| | 500mm Dia | Each | 522 | |
| | 600mm Dia | Each | 657 | |
| | 700mm Dia | Each | 801 | |
| | 750mm Dia | Each | 864 | |
| 3.3 | Providing, fixing including testing following double flanged cast iron (horizontal cast) pipe per IS: 7181 of Two Meterlength. | | | |
| | 80mm Dia | Each | 3087 | |
| | 100mm Dia | Each | 3915 | |
| | 125mm Dia | Each | 4859 | |
| | 150mm Dia | Each | 6034 | |
| | 200mm Dia | Each | 8382 | |
| | 250mm Dia | Each | 11166 | |
| | 300mm Dia | Each | 14259 | |
| | 350mm Dia | Each | 17599 | |
| | 400mm Dia | Each | 21791 | |
| | 450mm Dia | Each | 26406 | |
| | 500mm Dia | Each | 30592 | |
| | 600mm Dia | Each | 40657 | |
| | 700mm Dia | Each | 51766 | |
| | 750mm Dia | Each | 56636 | |
| 3.4 | Labour only for fixing including testing following double flanged cast iron (horizontal cast) pipe per IS: 7181 of Two Meter length. | | | |
| | 80mm Dia | Each | 148 | |
| | 100mm Dia | Each | 164 | |
| | 125mm Dia | Each | 184 | |
| | 150mm Dia | Each | 205 | |
| | 200mm Dia | Each | 246 | |
| | 250mm Dia | Each | 312 | |
| | 300mm Dia | Each | 367 | |
| | 350mm Dia | Each | 445 | |
| | 400mm Dia | Each | 557 | |
| | 450mm Dia | Each | 645 | |
| | 500mm Dia | Each | 725 | |
| | 600mm Dia | Each | 928 | |
| | 700mm Dia | Each | 1151 | |

| S.No. | ITEMS | Unit | Rates in Rs. | |
|-------|--|------|--------------|--|
| | 750mm Dia | Each | 1256 | |
| 3.5 | Providing, fixing including testing following double flanged cast iron (horizontal cast) pipe per IS: 7181 of 2.75 Meter length. | | | |
| | 80mm Dia | Each | 4113 | |
| | 100mm Dia | Each | 5202 | |
| | 125mm Dia | Each | 6493 | |
| | 150mm Dia | Each | 8078 | |
| | 200mm Dia | Each | 11292 | |
| | 250mm Dia | Each | 15032 | |
| | 300mm Dia | Each | 19264 | |
| | 350mm Dia | Each | 23741 | |
| | 400mm Dia | Each | 29322 | |
| | 450mm Dia | Each | 35535 | |
| | 500mm Dia | Each | 41189 | |
| | 600mm Dia | Each | 54810 | |
| | 700mm Dia | Each | 69705 | |
| | 750mm Dia | Each | 76363 | |
| 3.6 | Labour only for fixing including testing following double flanged cast iron (horizontal cast) pipe per IS: 7181 of 2.75 Meter length. | | | |
| | 80mm Dia | Each | 148 | |
| | 100mm Dia | Each | 164 | |
| | 125mm Dia | Each | 184 | |
| | 150mm Dia | Each | 205 | |
| | 200mm Dia | Each | 246 | |
| | 250mm Dia | Each | 312 | |
| | 300mm Dia | Each | 367 | |
| | 350mm Dia | Each | 445 | |
| | 400mm Dia | Each | 557 | |
| | 450mm Dia | Each | 645 | |
| | 500mm Dia | Each | 725 | |
| | 600mm Dia | Each | 928 | |
| | 700mm Dia | Each | 1151 | |
| | 750mm Dia | Each | 1256 | |
| 3.7 | Providing flanged joints to following double flanged cast iron (horizontal cast) pipes and specials class 'A' and 'B' including labour & cost of jointing materials (i.e. Bolt, Nuts and Rubber insertions) including testing of joint etc. complete. | | | |

| S.No. | ITEMS | Unit | Rates in Rs. | |
|-------|---|------|--------------|--|
| | 80mm Dia | Each | 158 | |
| | 100mm Dia | Each | 218 | |
| | 125mm Dia | Each | 222 | |
| | 150mm Dia | Each | 253 | |
| | 200mm Dia | Each | 256 | |
| | 250mm Dia | Each | 356 | |
| | 300mm Dia | Each | 362 | |
| | 350mm Dia | Each | 490 | |
| | 400mm Dia | Each | 711 | |
| | 450mm Dia | Each | 857 | |
| | 500mm Dia | Each | 963 | |
| | 600mm Dia | Each | 1187 | |
| | 700mm Dia | Each | 1614 | |
| | 750mm Dia | Each | 1624 | |
| | 800mm Dia | Each | 1787 | |
| | 900mm Dia | Each | 2139 | |
| | 1000mm Dia | Each | 2517 | |
| 3.8 | Labour for Providing Flanged joint to following flanged cast iron pipes and specials class 'A' and 'B' including testing of joints but excluding cost of jointing materials (i.e. Bolts & Nut, Rubber insertion) | | | |
| | 80mm Dia | Each | 56 | |
| | 100mm Dia | Each | 59 | |
| | 125mm Dia | Each | 62 | |
| | 150mm Dia | Each | 66 | |
| | 200mm Dia | Each | 69 | |
| | 250mm Dia | Each | 83 | |
| | 300mm Dia | Each | 89 | |
| | 350mm Dia | Each | 104 | |
| | 400mm Dia | Each | 134 | |
| | 450mm Dia | Each | 148 | |
| | 500mm Dia | Each | 159 | |
| | 600mm Dia | Each | 193 | |
| | 700mm Dia | Each | 226 | |
| | 750mm Dia | Each | 236 | |
| | 800mm Dia | Each | 250 | |
| | 900mm Dia | Each | 294 | |
| | 1000mm Dia | Each | 315 | |

| S.No. | ITEMS | Unit | Rates in Rs. | |
|------------|--|-------|---|--------------------|
| 3.9 | Labour only for providing flanged joints to following double flanged horizontally cast iron pipes and specials in vertical or inclined direction including testing of joints but excluding cost or jointing materials (i.e. bolts, nuts and rubber insertion sheet) | | | |
| | 80mm to 750mm dia in truly vertical position | | 200% above the rates provided vide item No.3.2, 3.4 & 3.6 | |
| | In inclined position at inclination 45% & above | | 100% above rates provided vide item No. 3.2, 3.4 & 3.6 | |
| | In inclined position at inclination less than 45% | | Same as rates provided vide item no. 3.2, 3.4 & 3.6 | |
| 3.10 | Providing & Laying in position including testing following cast iron flanged sockets (all sizes in mm) confirming to IS: 1538 | | | |
| | | | Medium Class | Heavy Class |
| | 80mm Dia | Each | 876 | 949 |
| | 100mm Dia | Each | 1095 | 1168 |
| | 125mm Dia | Each | 1387 | 1460 |
| | 150mm Dia | Each | 1825 | 1898 |
| | 200mm Dia | Each | 2628 | 2702 |
| | 250mm Dia | Each | 4234 | 4527 |
| | 300mm Dia | Each | 5402 | 5767 |
| | 350mm Dia | Each | 6862 | 7301 |
| | 400mm Dia | Each | 8469 | 8979 |
| | 450mm Dia | Each | 9783 | 10367 |
| | 500mm Dia | Each | 11899 | 12630 |
| | 600mm Dia | Each | 16134 | 17083 |
| | 700mm Dia | Each | 21098 | 22340 |
| | 750mm Dia | Each | 23945 | 25333 |
| | 800mm Dia | Each | 26982 | 28545 |
| 900mm Dia | Each | 32846 | 34751 | |
| 1000mm Dia | Each | 40023 | 42344 | |
| 3.11 | Providing and laying in position including testing following cast iron flanged spigot (tailpiece) | | | |
| | 80mm Dia | Each | 803 | 876 |
| | 100mm Dia | Each | 949 | 1022 |
| | 125mm Dia | Each | 1242 | 1387 |
| | 150mm Dia | Each | 1533 | 1679 |
| | 200mm Dia | Each | 2555 | 2847 |
| | 250mm Dia | Each | 3432 | 3869 |
| 300mm Dia | Each | 4380 | 4964 | |

| S.No. | ITEMS | Unit | Rates in Rs. | |
|-------|--|------|---------------------|--------------------|
| | 350mm Dia | Each | 5549 | 6205 |
| | 400mm Dia | Each | 6717 | 7592 |
| | 450mm Dia | Each | 7957 | 8979 |
| | 500mm Dia | Each | 9491 | 10659 |
| | 600mm Dia | Each | 14674 | 16573 |
| | 700mm Dia | Each | 19055 | 21537 |
| | 750mm Dia | Each | 21610 | 24384 |
| | 800mm Dia | Each | 24087 | 24395 |
| | 900mm Dia | Each | 28926 | 34709 |
| | 1000mm Dia | Each | 34761 | 39787 |
| 3.12 | Providing and laying in position including testing following cast iron double flanged 90° bends (all sizes inmm) | | Medium Class | Heavy Class |
| | 80mm Dia | Each | 876 | 949 |
| | 100mm Dia | Each | 1168 | 1679 |
| | 125mm Dia | Each | 1533 | 2263 |
| | 150mm Dia | Each | 2117 | 3577 |
| | 200mm Dia | Each | 3285 | 5257 |
| | 250mm Dia | Each | 4745 | 7301 |
| | 300mm Dia | Each | 6570 | 10002 |
| | 350mm Dia | Each | 8979 | 13214 |
| | 400mm Dia | Each | 11827 | 16499 |
| | 450mm Dia | Each | 18835 | 21172 |
| | 500mm Dia | Each | 28619 | 32269 |
| | 600mm Dia | Each | 41321 | 46650 |
| | 700mm Dia | Each | 48767 | 55119 |
| | 750mm Dia | Each | 57556 | 65129 |
| | 800mm Dia | Each | 67811 | 76775 |
| | 900mm Dia | Each | 89351 | 101707 |
| | 1000mm Dia | Each | 117268 | 133192 |
| 3.13 | Providing and laying in position including testing following cast iron double flanged 45° bends (all sizes in mm) | | | |
| | 80mm Dia | Each | 965 | 1022 |
| | 100mm Dia | Each | 1240 | 1314 |
| | 125mm Dia | Each | 1722 | 1825 |
| | 150mm Dia | Each | 2343 | 2482 |
| | 200mm Dia | Each | 3720 | 3942 |
| | 250mm Dia | Each | 5511 | 5840 |
| | 300mm Dia | Each | 7716 | 8177 |
| | 350mm Dia | Each | 7923 | 8396 |
| | 400mm Dia | Each | 10266 | 10878 |
| | 450mm Dia | Each | 12745 | 13506 |

| S.No. | ITEMS | Unit | Rates in Rs. | |
|-------|--|------|---------------------|--------------------|
| | 500mm Dia | Each | 15915 | 16864 |
| | 600mm Dia | Each | 23562 | 24968 |
| | 700mm Dia | Each | 33414 | 35408 |
| | 750mm Dia | Each | 39407 | 41760 |
| 3.14 | Providing and laying in position including testing following cast iron double flanged 90° Duck Foot Bend | | Medium Class | Heavy Class |
| | 80mm Dia | Each | 1460 | 1533 |
| | 100mm Dia | Each | 1825 | 1898 |
| | 125mm Dia | Each | 2482 | 2628 |
| | 150mm Dia | Each | 3285 | 3432 |
| | 200mm Dia | Each | 5110 | 5402 |
| | 250mm Dia | Each | 7592 | 8104 |
| | 300mm Dia | Each | 10659 | 11389 |
| | 350mm Dia | Each | 14601 | 15623 |
| | 400mm Dia | Each | 19128 | 20515 |
| | 450mm Dia | Each | 23727 | 25552 |
| | 500mm Dia | Each | 30224 | 32561 |
| | 600mm Dia | Each | 45775 | 49425 |
| 3.15 | Providing and laying in position including testing following cast iron all flanged Tees (all sizes in mm) Body x Branch | | Medium Class | Heavy Class |
| | 80x80 | Each | 1460 | 1533 |
| | 100x80 | Each | 1679 | 1825 |
| | 100x100 | Each | 1752 | 1898 |
| | 125x80 | Each | 2117 | 2337 |
| | 125x100 | Each | 2337 | 2482 |
| | 125x125 | Each | 2409 | 2628 |
| | 150x80 | Each | 2774 | 2993 |
| | 150x100 | Each | 2847 | 3067 |
| | 150x125 | Each | 2993 | 3285 |
| | 150x150 | Each | 3139 | 3432 |
| | 200x80 | Each | 4089 | 4527 |
| | 200x100 | Each | 4162 | 4599 |
| | 200x125 | Each | 4380 | 4819 |
| | 200x150 | Each | 4527 | 4964 |
| | 200x200 | Each | 4892 | 5402 |
| | 250x80 | Each | 5840 | 6497 |
| | 250x100 | Each | 5914 | 6570 |
| | 250x125 | Each | 6132 | 6789 |
| | 250x150 | Each | 6352 | 7009 |
| | 250x200 | Each | 6717 | 7447 |
| | 250x250 | Each | 7227 | 7957 |

| S.No. | ITEMS | Unit | Rates in Rs. | |
|--------------|--------------|-------------|---------------------|-------|
| | 300x80 | Each | 7957 | 8907 |
| | 300x100 | Each | 8104 | 9052 |
| | 300x125 | Each | 8249 | 9199 |
| | 300x150 | Each | 8469 | 9418 |
| | 300x200 | Each | 8907 | 9929 |
| | 300x250 | Each | 9418 | 10439 |
| | 300x300 | Each | 9929 | 11024 |
| | 350x200 | Each | 11097 | 12338 |
| | 350x250 | Each | 11389 | 12630 |
| | 350x300 | Each | 12411 | 13725 |
| | 350x350 | Each | 12776 | 14236 |
| | 400x200 | Each | 13798 | 15404 |
| | 400x250 | Each | 14090 | 15696 |
| | 400x300 | Each | 15185 | 16938 |
| | 400x350 | Each | 15623 | 17448 |
| | 400x400 | Each | 16134 | 17960 |
| | 450x250 | Each | 16938 | 18981 |
| | 450x300 | Each | 18033 | 20223 |
| | 450x350 | Each | 18470 | 20733 |
| | 450x400 | Each | 18908 | 21172 |
| | 450x450 | Each | 19346 | 21610 |
| | 500x250 | Each | 20515 | 22997 |
| | 500x300 | Each | 21755 | 24384 |
| | 500x350 | Each | 22267 | 24968 |
| | 500x400 | Each | 22778 | 25479 |
| | 500x450 | Each | 23215 | 25990 |
| | 500x500 | Each | 23727 | 26501 |
| | 600x300 | Each | 30224 | 34021 |
| | 600x350 | Each | 30954 | 34678 |
| | 600x400 | Each | 31539 | 35408 |
| | 600x450 | Each | 31976 | 35919 |
| | 600x500 | Each | 32487 | 36430 |
| | 600x600 | Each | 33656 | 37671 |
| | 700x350 | Each | 41613 | 46870 |
| | 700x400 | Each | 42197 | 47527 |
| | 700x450 | Each | 42855 | 48184 |
| | 700x500 | Each | 43438 | 48840 |
| | 700x600 | Each | 44607 | 50082 |
| | 700x700 | Each | 46140 | 51615 |
| | 750x400 | Each | 48330 | 54462 |
| | 750x450 | Each | 48914 | 55046 |
| | 750x500 | Each | 49717 | 55922 |
| | 750x600 | Each | 50666 | 56871 |
| | 750x700 | Each | 51615 | 57821 |
| | 800x400 | Each | 55631 | 62638 |

| S.No. | ITEMS | Unit | Rates in Rs. | |
|--------------|--|-------------|---------------------|--------------------|
| | 800x450 | Each | 56214 | 63296 |
| | 800x500 | Each | 56871 | 64026 |
| | 800x600 | Each | 58258 | 65486 |
| | 800x700 | Each | 59646 | 66873 |
| | 800x750 | Each | 60448 | 67749 |
| | 800x800 | Each | 61398 | 68698 |
| | 900x450 | Each | 70524 | 79649 |
| | 900x500 | Each | 71545 | 80744 |
| | 900x600 | Each | 73006 | 82350 |
| | 900x700 | Each | 74466 | 83883 |
| | 900x750 | Each | 75342 | 84760 |
| | 900x800 | Each | 76218 | 85635 |
| | 900x900 | Each | 77459 | 86877 |
| 3.16 | Providing and laying in position including testing following cast iron double flanged Tapers (all size in mm) Body x Branch | | Medium Class | Heavy Class |
| | 100x80 | Each | 803 | 876 |
| | 125x80 | Each | 1314 | 1460 |
| | 125x100 | Each | 1460 | 1607 |
| | 150x80 | Each | 1533 | 1679 |
| | 150x100 | Each | 1679 | 1825 |
| | 150x125 | Each | 1825 | 1972 |
| | 200x100 | Each | 2117 | 2263 |
| | 200x125 | Each | 2263 | 2482 |
| | 200x150 | Each | 2482 | 2702 |
| | 250x125 | Each | 2774 | 2993 |
| | 250x150 | Each | 2920 | 3212 |
| | 250x200 | Each | 3358 | 3650 |
| | 300x150 | Each | 3432 | 3723 |
| | 300x200 | Each | 3869 | 4234 |
| | 300x250 | Each | 4380 | 4745 |
| | 350x200 | Each | 5767 | 6352 |
| | 350x250 | Each | 6352 | 7009 |
| | 350x300 | Each | 7009 | 7739 |
| | 400x250 | Each | 7154 | 7957 |
| | 400x300 | Each | 7884 | 8761 |
| | 400x350 | Each | 8687 | 9637 |
| | 450x300 | Each | 8542 | 9491 |
| | 450x350 | Each | 9564 | 10586 |
| | 450x400 | Each | 10439 | 11534 |
| | 500x350 | Each | 10513 | 11681 |
| | 500x400 | Each | 11462 | 12703 |
| | 500x450 | Each | 12265 | 13579 |

| S.No. | ITEMS | Unit | Rates in Rs. | |
|-------|---|------|--------------|-------|
| | 600x400 | Each | 13871 | 15331 |
| | 600x450 | Each | 14601 | 16208 |
| | 600x500 | Each | 15769 | 17448 |
| | 700x500 | Each | 18543 | 20515 |
| | 700x600 | Each | 20953 | 23143 |
| | 750x600 | Each | 22340 | 24675 |
| | 750x700 | Each | 24384 | 26866 |
| | 800x600 | Each | 25114 | 27742 |
| | 800x700 | Each | 27158 | 29932 |
| | 800x750 | Each | 28326 | 31246 |
| | 900x700 | Each | 30297 | 33436 |
| | 900x750 | Each | 31611 | 34896 |
| | 900X800 | Each | 33656 | 37086 |
| | 1000x800 | Each | 37816 | 41613 |
| | 1000x900 | Each | 40883 | 45045 |
| 3.17 | Providing and laying in position including testing following all flanged cast iron crosses (all sizes in mm) | | | |
| | 80mm Dia | Each | 1825 | 1972 |
| | 100mm Dia | Each | 2263 | 2482 |
| | 125mm Dia | Each | 2993 | 3358 |
| | 150mm Dia | Each | 3942 | 4380 |
| | 200mm Dia | Each | 6132 | 6789 |
| | 250mm Dia | Each | 8907 | 9856 |
| | 300mm Dia | Each | 12046 | 13141 |
| 3.18 | Providing and laying in position including testing following all flanged cast iron blank flanges (all sizes in mm) | | | |
| | 80mm Dia | Each | 328 | 365 |
| | 100mm Dia | Each | 395 | 438 |
| | 125mm Dia | Each | 526 | 584 |
| | 150mm Dia | Each | 723 | 803 |
| | 200mm Dia | Each | 1051 | 1168 |
| | 250mm Dia | Each | 1511 | 1679 |
| | 300mm Dia | Each | 2103 | 2337 |
| | 350mm Dia | Each | 2826 | 3139 |
| | 400mm Dia | Each | 3614 | 4015 |
| | 450mm Dia | Each | 4403 | 4892 |
| | 500mm Dia | Each | 5585 | 6205 |
| | 600mm Dia | Each | 8279 | 9199 |
| | 700mm Dia | Each | 11630 | 12922 |
| | 750mm Dia | Each | 13601 | 15113 |
| | 800mm Dia | Each | 16098 | 17886 |

| S.No. | ITEMS | Unit | Rates in Rs. | |
|-------|--|------|---------------------|--------------------|
| | 900mm Dia | Each | 20566 | 22850 |
| | 1000mm Dia | Each | 26677 | 29640 |
| 3.19 | Labour for laying in position including testing following cast iron flanged sockets (all sizes in mm) | | Medium Class | Heavy Class |
| | 80mm Dia | Each | 25 | 27 |
| | 100mm Dia | Each | 33 | 35 |
| | 125mm Dia | Each | 41 | 43 |
| | 150mm Dia | Each | 54 | 56 |
| | 200mm Dia | Each | 77 | 79 |
| | 250mm Dia | Each | 124 | 133 |
| | 300mm Dia | Each | 159 | 170 |
| | 350mm Dia | Each | 201 | 215 |
| | 400mm Dia | Each | 249 | 264 |
| | 450mm Dia | Each | 288 | 305 |
| | 500mm Dia | Each | 350 | 371 |
| | 600mm Dia | Each | 474 | 502 |
| | 700mm Dia | Each | 620 | 657 |
| | 750mm Dia | Each | 704 | 744 |
| | 800mm Dia | Each | 793 | 839 |
| | 900mm Dia | Each | 965 | 1021 |
| | 1000mm Dia | Each | 1176 | 1245 |
| 3.20 | Labour for laying in position including testing following cast iron flanged Spigot (all sizes in mm) | | Medium Class | Heavy Class |
| | 80mm Dia | Each | 23 | 25 |
| | 100mm Dia | Each | 27 | 31 |
| | 125mm Dia | Each | 37 | 41 |
| | 150mm Dia | Each | 45 | 50 |
| | 200mm Dia | Each | 75 | 83 |
| | 250mm Dia | Each | 101 | 114 |
| | 300mm Dia | Each | 129 | 145 |
| | 350mm Dia | Each | 163 | 182 |
| | 400mm Dia | Each | 197 | 223 |
| | 450mm Dia | Each | 234 | 264 |
| | 500mm Dia | Each | 279 | 313 |
| | 600mm Dia | Each | 431 | 487 |
| | 700mm Dia | Each | 560 | 632 |
| | 750mm Dia | Each | 635 | 717 |
| | 800mm Dia | Each | 708 | 717 |
| | 900mm Dia | Each | 850 | 1020 |
| | 1000mm Dia | Each | 1022 | 1169 |

| S.No. | ITEMS | Unit | Rates in Rs. | |
|------------|---|------|---------------------|--------------------|
| 3.21 | Labour for laying in position including testing following cast iron double flanged 90° Bend (all sizes in mm) | | Medium Class | Heavy class |
| | 80mm Dia | Each | 25 | 27 |
| | 100mm Dia | Each | 35 | 50 |
| | 125mm Dia | Each | 45 | 66 |
| | 150mm Dia | Each | 62 | 105 |
| | 200mm Dia | Each | 97 | 155 |
| | 250mm Dia | Each | 139 | 215 |
| | 300mm Dia | Each | 193 | 294 |
| | 350mm Dia | Each | 264 | 388 |
| | 400mm Dia | Each | 348 | 485 |
| | 450mm Dia | Each | 553 | 622 |
| | 500mm Dia | Each | 841 | 949 |
| | 600mm Dia | Each | 1214 | 1371 |
| | 700mm Dia | Each | 1433 | 1620 |
| | 750mm Dia | Each | 1691 | 1914 |
| | 800mm Dia | Each | 1993 | 2256 |
| | 900mm Dia | Each | 2625 | 2989 |
| 1000mm Dia | Each | 3446 | 3915 | |
| 3.22 | Labour for laying in position including testing following cast iron double flanged 45° bend (all sizes in mm) | | | |
| | 80mm Dia | Each | 27 | 31 |
| | 100mm Dia | Each | 35 | 39 |
| | 125mm Dia | Each | 48 | 54 |
| | 150mm Dia | Each | 66 | 73 |
| | 200mm Dia | Each | 105 | 116 |
| | 250mm Dia | Each | 155 | 172 |
| | 300mm Dia | Each | 217 | 240 |
| | 350mm Dia | Each | 222 | 247 |
| | 400mm Dia | Each | 288 | 319 |
| | 450mm Dia | Each | 357 | 397 |
| | 500mm Dia | Each | 446 | 495 |
| | 600mm Dia | Each | 660 | 734 |
| | 700mm Dia | Each | 936 | 1040 |
| 750mm Dia | Each | 1104 | 1227 | |
| 3.23 | Labour for laying in position including testing following cast iron double flanged 90° duck foot bend. (all sizes in mm) | | Medium Class | Heavy Class |
| | 80mm Dia | Each | 43 | 45 |
| | 100mm Dia | Each | 54 | 56 |

| S.No. | ITEMS | Unit | Rates in Rs. | |
|-------|---|------|---------------------|--------------------|
| | 125mm Dia | Each | 73 | 77 |
| | 150mm Dia | Each | 97 | 101 |
| | 200mm Dia | Each | 150 | 159 |
| | 250mm Dia | Each | 223 | 238 |
| | 300mm Dia | Each | 313 | 335 |
| | 350mm Dia | Each | 429 | 460 |
| | 400mm Dia | Each | 562 | 603 |
| | 450mm Dia | Each | 698 | 751 |
| | 500mm Dia | Each | 889 | 957 |
| | 600mm Dia | Each | 1345 | 1452 |
| 3.24 | Labour for laying in position including testing following cast iron all flanged tees (all sizes in mm) Body x Branch | | Medium Class | Heavy Class |
| | 80x80 | Each | 43 | 45 |
| | 100x80 | Each | 50 | 54 |
| | 100x100 | Each | 52 | 56 |
| | 125x80 | Each | 62 | 69 |
| | 125x100 | Each | 69 | 73 |
| | 125x125 | Each | 71 | 77 |
| | 150x80 | Each | 81 | 88 |
| | 150x100 | Each | 83 | 90 |
| | 150x125 | Each | 88 | 97 |
| | 150x150 | Each | 93 | 101 |
| | 200x80 | Each | 120 | 133 |
| | 200x100 | Each | 122 | 135 |
| | 200x125 | Each | 129 | 141 |
| | 200x150 | Each | 133 | 145 |
| | 200x200 | Each | 143 | 159 |
| | 250x80 | Each | 172 | 191 |
| | 250x100 | Each | 174 | 193 |
| | 250x125 | Each | 180 | 199 |
| | 250x150 | Each | 187 | 206 |
| | 250x200 | Each | 197 | 219 |
| | 250x250 | Each | 213 | 234 |
| | 300x80 | Each | 234 | 261 |
| | 300x100 | Each | 238 | 266 |
| | 300x125 | Each | 242 | 270 |
| | 300x150 | Each | 249 | 277 |
| | 300x200 | Each | 261 | 292 |
| | 300x250 | Each | 277 | 307 |
| | 300x300 | Each | 292 | 324 |
| | 350x200 | Each | 326 | 363 |
| | 350x250 | Each | 335 | 371 |
| | 350x300 | Each | 365 | 404 |

| S.No. | ITEMS | Unit | Rates in Rs. | |
|--------------|--------------|-------------|---------------------|------|
| | 350x350 | Each | 375 | 418 |
| | 400x200 | Each | 406 | 452 |
| | 400x250 | Each | 414 | 462 |
| | 400x300 | Each | 446 | 498 |
| | 400x350 | Each | 460 | 512 |
| | 400x400 | Each | 474 | 528 |
| | 450x250 | Each | 498 | 558 |
| | 450x300 | Each | 530 | 594 |
| | 450x350 | Each | 543 | 609 |
| | 450x400 | Each | 555 | 622 |
| | 450x450 | Each | 568 | 635 |
| | 500x250 | Each | 603 | 676 |
| | 500x300 | Each | 640 | 717 |
| | 500x350 | Each | 655 | 734 |
| | 500x400 | Each | 669 | 748 |
| | 500x450 | Each | 682 | 764 |
| | 500x500 | Each | 698 | 779 |
| | 600x300 | Each | 889 | 1000 |
| | 600x350 | Each | 910 | 1019 |
| | 600x400 | Each | 927 | 1040 |
| | 600x450 | Each | 940 | 1055 |
| | 600x500 | Each | 955 | 1071 |
| | 600x600 | Each | 989 | 1107 |
| | 700x350 | Each | 1223 | 1378 |
| | 700x400 | Each | 1240 | 1397 |
| | 700x450 | Each | 1260 | 1416 |
| | 700x500 | Each | 1276 | 1436 |
| | 700x600 | Each | 1311 | 1471 |
| | 700x700 | Each | 1356 | 1517 |
| | 750x400 | Each | 1420 | 1600 |
| | 750x450 | Each | 1438 | 1618 |
| | 750x500 | Each | 1461 | 1643 |
| | 750X600 | Each | 1489 | 1672 |
| | 750x700 | Each | 1517 | 1699 |
| | 750x750 | Each | 1545 | 1728 |
| | 800x400 | Each | 1635 | 1840 |
| | 800x450 | Each | 1652 | 1860 |
| | 800x500 | Each | 1672 | 1881 |
| | 800x600 | Each | 1712 | 1925 |
| | 800x700 | Each | 1753 | 1965 |
| | 800x750 | Each | 1776 | 1991 |
| | 800x800 | Each | 1805 | 2019 |
| | 900x450 | Each | 2072 | 2341 |
| | 900x500 | Each | 2103 | 2373 |
| | 900x600 | Each | 2145 | 2420 |

| S.No. | ITEMS | Unit | Rates in Rs. | |
|-------|--|------|---------------------|--------------------|
| | 900x700 | Each | 2188 | 2465 |
| | 900x750 | Each | 2215 | 2491 |
| | 900x800 | Each | 2240 | 2517 |
| | 900x900 | Each | 2277 | 2553 |
| 3.25 | Labour for laying in position including testing following cast iron double flanged Tapers (all sizes in mm) | | | |
| | Body x Branch | | Medium Class | Heavy Class |
| | 100x80 | Each | 23 | 25 |
| | 125x80 | Each | 39 | 43 |
| | 125x100 | Each | 43 | 47 |
| | 150x80 | Each | 45 | 50 |
| | 150x100 | Each | 50 | 54 |
| | 150x125 | Each | 54 | 58 |
| | 200x100 | Each | 62 | 66 |
| | 200x125 | Each | 66 | 73 |
| | 200x150 | Each | 73 | 79 |
| | 250x125 | Each | 81 | 88 |
| | 250x150 | Each | 85 | 95 |
| | 250x200 | Each | 99 | 108 |
| | 300x150 | Each | 101 | 110 |
| | 300x200 | Each | 114 | 124 |
| | 300x250 | Each | 129 | 139 |
| | 350x200 | Each | 170 | 187 |
| | 350x250 | Each | 187 | 206 |
| | 350x300 | Each | 206 | 228 |
| | 400x250 | Each | 210 | 234 |
| | 400x300 | Each | 232 | 257 |
| | 400x350 | Each | 255 | 284 |
| | 450x300 | Each | 251 | 279 |
| | 450x350 | Each | 281 | 311 |
| | 450x400 | Each | 307 | 339 |
| | 500x350 | Each | 309 | 344 |
| | 500x400 | Each | 337 | 373 |
| | 500x450 | Each | 360 | 399 |
| | 600x400 | Each | 408 | 450 |
| | 600x450 | Each | 429 | 476 |
| | 600x500 | Each | 464 | 512 |
| | 700x500 | Each | 545 | 603 |
| | 700x600 | Each | 616 | 680 |
| | 750x600 | Each | 657 | 725 |
| | 750x700 | Each | 717 | 789 |
| | 800x600 | Each | 738 | 815 |

| S.No. | ITEMS | Unit | Rates in Rs. | |
|-------|--|------|---------------------|--------------------|
| | 800x700 | Each | 798 | 880 |
| | 800x750 | Each | 833 | 918 |
| | 900x700 | Each | 891 | 982 |
| | 900x750 | Each | 929 | 1026 |
| | 900x800 | Each | 989 | 1090 |
| | 1000x800 | Each | 1111 | 1223 |
| | 1000x900 | Each | 1202 | 1324 |
| | Labour for laying in position including testing following all flanged cast iron crosses (all sizes in mm) | | Medium Class | Heavy Class |
| | 80mmDia | Each | 54 | 58 |
| | 100mm Dia | Each | 66 | 73 |
| | 125mm Dia | Each | 88 | 99 |
| | 150mm Dia | Each | 116 | 129 |
| | 200mm Dia | Each | 180 | 199 |
| | 250mm Dia | Each | 261 | 290 |
| | 300mm Dia | Each | 354 | 386 |
| | Labour for laying in position including testing following cast iron blank flanges (all sizes in mm) | | | |
| | 80mmDia | Each | 9 | 11 |
| | 100mm Dia | Each | 11 | 13 |
| | 125mm Dia | Each | 15 | 17 |
| | 150mm Dia | Each | 21 | 23 |
| | 200mm Dia | Each | 31 | 35 |
| | 250mm Dia | Each | 45 | 50 |
| | 300mm Dia | Each | 62 | 69 |
| | 350mm Dia | Each | 83 | 93 |
| | 400mm Dia | Each | 106 | 118 |
| | 450mm Dia | Each | 129 | 143 |
| | 500mm Dia | Each | 164 | 182 |
| | 600mm Dia | Each | 243 | 270 |
| | 700mm Dia | Each | 342 | 379 |
| | 750mm Dia | Each | 400 | 444 |
| | 800mm Dia | Each | 473 | 526 |
| | 900mm Dia | Each | 604 | 671 |
| | 1000mm Dia | Each | 784 | 871 |
| 3.28 | Providing and laying in position including testing following sizes of flanged cast iron standard specials class medium or heavy which does not appear in above items of the schedule. | | Medium Class | Heavy Class |

| S.No. | ITEMS | Unit | Rates in Rs. | |
|-------|---|------|--|----|
| | 80mm to 300mm dia | Kg | 63 | 63 |
| | Above 300mm dia | Kg | 72 | 72 |
| 3.29 | Labour for laying in position including testing following sizes of flanges, cast iron standard specials which does not appear in above items of the schedule | | | |
| | 80mm to 750mm dia | Kg | 2 | 2 |
| 3.30 | Labour only for laying including testing following Horizontal Cast Iron Pipes in inclined or vertical position:- | | | |
| | 80mm to 750mm dia | | <ul style="list-style-type: none"> • In truly vertical position 200% above rates provided vide item No. 3.2, 3.4, and 3.6. • In inclined position at inclination less than 45% Same as rates provided vide item No. 3.2, 3.4 and 3.6 | |

CHAPTER – IV

DUCTILE IRON PRESSURE PIPES WITH

(TYTON JOINTS)

VALVES AND SPECIALS

Chapter – IV
DUCTILE IRON PRESSURE PIPES WITH
(TYTON JOINTS) VALVES AND SPECIALS

NOTES:

- 1 All the pipes, specials, joints to be used in the work shall confirm to relevant Indian standard duly inspected and tested and having B.I.S. certification Mark.
- 2 The jointing materials i.e. Tyton rings if supplied by the Department from departmental store, no extra charges for carting of the same to site of work will be payable. In case jointing materials are required to be arranged by the contractor the same should confirm to relevant Indian standard duly inspected and tested and bearing B.I.S. certification Mark.
- 3 The rates include charges for all tools and plant, chain pulley blocks, other appliances etc. required for lifting and laying the pipes and specials in position including testing as per approved drawings.
- 4 The rates include provision and use of all coverings etc. to protect the work from inclement weather etc. and from damages from falling materials and other causes.
- 5 The rate include provision of handling, storing under cover as required and returning of empty cases or container to Public Health Engineering Department Stores without any extra cost, for such materials as may be supplied by the department.
- 6 All measurements should be of the finished work.
- 7 Fitting must of superior quality & equivalent to Kiswak /Electrosteel/Kejriwal/Jindal.
- 8 Rates include the supply of pipes and specials at departmental store/site store.
- 9 Works will be executed in accordance with the general specifications given in P.H.E. Department and the specials notes if any, covered in the contract agreement of the work and all the relevant latest version of I.S. Specifications as detailed below:-

| S.No. | I.S. Number | Title |
|-------|-------------------------------|--|
| 1. | IS 8329:2000 | Centrifugally cast (spun) ductile iron pressure pipes for water, gas and sewage (Third revision) |
| | IS 11906:1986 | Cement mortar lining in the pipes. |
| 2. | IS 9523:2000 | Ductile Iron fittings for pressure pipes for water, gas and sewage. |
| 3. | IS 12288:1987 | Code of practice for use and laying of ductile iron pipes. |
| 4. | IS 5382:2018 | Rubber sealing rings for gas mains, water mains and sewage (First revision) |
| 5. | IS 14846:2000 | The Sluice Valves (50-1200 mm size) |
| 6. | IS 14845: 2000 | The resilient seated C.I. Air relief valve |
| 7. | IS 5312: 2004(Part I & II) | The Swing check type reflux valves |
| 8. | IS 13095:1991 | The Butter fly valves |

10. This USOR contains the rates of all the items without GST. No claims against GST shall be entertained at any level. GST shall be paid by the Agency/ Contractor directly to the concerning department. However, All the estimates prepared on this USOR will include GST, as an extra amount as per prevailing rates on the sum of the estimate to arrive at the gross amount.

DUCTILE IRON PRESSURE PIPES WITH (TYTON JOINTS) VALVES AND SPECIALS

| S. No. | Items | Unit | Rates in Rs. |
|------------|--|-------|--------------|
| 4.1 | Providing, laying and jointing including testing following socket & spigot centrifugally cast (Spun) Ductile Iron pressure pipes with inside cement mortar lining (class K-7) conforming to IS: 8329/ 2000 with suitable Rubber Gasket (Push on) joints as per IS:5382/2018 | | |
| | 100mm Dia | Metre | 943 |
| | 150mm Dia | Metre | 1324 |
| | 200mm Dia | Metre | 1733 |
| | 250mm Dia | Metre | 2284 |
| | 300mm Dia | Metre | 2908 |
| | 350mm Dia | Metre | 3496 |
| | 400mm Dia | Metre | 4237 |
| | 450mm Dia | Metre | 5032 |
| | 500mm Dia | Metre | 6030 |
| | 600mm Dia | Metre | 7862 |
| | 700mm Dia | Metre | 10911 |
| | 750mm Dia | Metre | 12314 |
| | 800mm Dia | Metre | 13822 |
| 900mm Dia | Metre | 16817 | |
| 1000mm Dia | Metre | 20223 | |
| 4.2 | Labour for laying in position including testing following socket & spigot Ductile Iron (K-7) pressure pipes | | |
| | 100mm Dia | Metre | 21 |
| | 150mm Dia | Metre | 29 |
| | 200mm Dia | Metre | 45 |
| | 250mm Dia | Metre | 59 |
| | 300mm Dia | Metre | 74 |
| | 350mm Dia | Metre | 99 |
| | 400mm Dia | Metre | 118 |

| S. No. | Items | Unit | Rates in Rs. |
|--------|---|-------|--------------|
| | 450mm Dia | Metre | 139 |
| | 500mm Dia | Metre | 163 |
| | 600mm Dia | Metre | 215 |
| | 700mm Dia | Metre | 272 |
| | 750mm Dia | Metre | 357 |
| | 800mm Dia | Metre | 452 |
| | 900mm Dia | Metre | 556 |
| | 1000mm Dia | Metre | 671 |
| 4.3 | Providing, laying and jointing including testing following socket & spigot centrifugally cast (Spun) Ductile Iron pressure pipes with inside cement mortar lining (class K-9) conforming to IS 8329 /2000 with suitable Rubber Gasket (Push on) joints as per IS:5382/2018 | | |
| | 100mm Dia | Metre | 1058 |
| | 150mm Dia | Metre | 1494 |
| | 200mm Dia | Metre | 2037 |
| | 250mm Dia | Metre | 2724 |
| | 300mm Dia | Metre | 3461 |
| | 350mm Dia | Metre | 4193 |
| | 400mm Dia | Metre | 5055 |
| | 450mm Dia | Metre | 5986 |
| | 500mm Dia | Metre | 7104 |
| | 600mm Dia | Metre | 9266 |
| | 700mm Dia | Metre | 12170 |
| | 750mm Dia | Metre | 13486 |
| | 800mm Dia | Metre | 14762 |
| | 900mm Dia | Metre | 17950 |
| | 1000mm Dia | Metre | 21569 |
| 4.4 | Labour for laying in position including testing following socket & spigot Ductile Iron (K-9) pressure pipes | Metre | |
| | 100mm Dia | Metre | 21 |
| | 150mm Dia | Metre | 29 |
| | 200mm Dia | Metre | 45 |
| | 250mm Dia | Metre | 59 |
| | 300mm Dia | Metre | 74 |
| | 350mm Dia | Metre | 99 |
| | 400mm Dia | Metre | 118 |
| | 450mm Dia | Metre | 139 |
| | 500mm Dia | Metre | 163 |

| S. No. | Items | Unit | Rates in Rs. |
|--------|---|-------|--------------|
| | 600mm Dia | Metre | 215 |
| | 700mm Dia | Metre | 272 |
| | 750mm Dia | Metre | 357 |
| | 800mm Dia | Metre | 452 |
| | 900mm Dia | Metre | 556 |
| | 1000mm Dia | Metre | 671 |
| 4.5 | Providing Rubber ISI marked Gasket (push on) joint as per IS:5382/2018 to following DI pipes class K-7 and K-9 including testing of joints and cost of jointing materials (Rubber Gasket and soap solution etc.) | | |
| | 100mm Dia | Each | 94 |
| | 150mm Dia | Each | 119 |
| | 200mm Dia | Each | 194 |
| | 250mm Dia | Each | 232 |
| | 300mm Dia | Each | 297 |
| | 350mm Dia | Each | 341 |
| | 400mm Dia | Each | 565 |
| | 450mm Dia | Each | 651 |
| | 500mm Dia | Each | 663 |
| | 600mm Dia | Each | 822 |
| | 700mm Dia | Each | 1142 |
| | 750mm Dia | Each | 1254 |
| | 800mm Dia | Each | 1328 |
| | 900mm Dia | Each | 1592 |
| | 1000mm Dia | Each | 1818 |
| 4.6 | Labour for providing including testing, Rubber Gasket (push on) joints to following D.I. Pipes class K-7 & K-9 including joints but excluding cost of Rubber Gasket. | | |
| | 100mm Dia | Each | 59 |
| | 150mm Dia | Each | 66 |
| | 200mm Dia | Each | 69 |
| | 250mm Dia | Each | 83 |
| | 300mm Dia | Each | 89 |
| | 350mm Dia | Each | 104 |
| | 400mm Dia | Each | 134 |
| | 450mm Dia | Each | 148 |
| | 500mm Dia | Each | 159 |

| S. No. | Items | Unit | Rates in Rs. |
|---|---|------|--------------|
| | 600mm Dia | Each | 193 |
| | 700mm Dia | Each | 226 |
| | 750mm Dia | Each | 236 |
| | 800mm Dia | Each | 250 |
| | 900mm Dia | Each | 294 |
| | 1000mm Dia | Each | 315 |
| DUCTILE IRON FITTING PN- 16 | | | |
| Note:-If PN-10 fitting is used than 90% of rate is payable for providing and fixing of fitting. | | | |
| 4.7 | Providing and Laying including testing ductile iron PN 16 type flanged sockets conforming to IS: 9523/2000 having dimension as per table 23 of IS: 9523/2000 in the following nominal diameter/sizes with external bitumen coating and internal cement mortar lining with finishing as per clause 13 of IS:9523/2000. | | |
| | 100mm | Each | 1033 |
| | 150mm | Each | 1608 |
| | 200mm | Each | 2411 |
| | 250mm | Each | 3215 |
| | 300mm | Each | 4248 |
| | 350mm | Each | 6606 |
| | 400mm | Each | 8395 |
| | 450mm | Each | 10459 |
| | 500mm | Each | 13211 |
| | 600mm | Each | 18147 |
| | 700mm | Each | 28857 |
| | 750mm | Each | 31637 |
| | 800mm | Each | 38417 |
| | 900mm | Each | 47804 |
| | 1000mm | Each | 61885 |
| 4.8 | Labour only for Laying including testing Ductile Iron PN 16 type flanged sockets conforming to IS: 9523/2000 having dimension as per table 23 of IS: 9523/2000 in the following nominal diameter/sizes with external bitumen coating and internal cement mortar lining with finishing as per clause 13 of IS: 9523/2000. | | |
| | 100mm | Each | 19 |
| | 150mm | Each | 31 |
| | 200mm | Each | 45 |

| S. No. | Items | Unit | Rates in Rs. |
|--------|--|------|--------------|
| | 250mm | Each | 60 |
| | 300mm | Each | 79 |
| | 350mm | Each | 103 |
| | 400mm | Each | 131 |
| | 450mm | Each | 163 |
| | 500mm | Each | 206 |
| | 600mm | Each | 264 |
| | 700mm | Each | 356 |
| | 750mm | Each | 390 |
| | 800mm | Each | 474 |
| | 900mm | Each | 590 |
| | 1000mm | Each | 764 |
| 4.9 | Providing and Laying including testing ductile PN 16 type iron flanged spigot conforming to IS: 9523/2000 having dimension as per table 24 of IS: 9523/2000 in the following nominal diameter/sizes with external bitumen coating and internal cement mortar lining with finishing as per clause 13 of IS: 9523/2000. | | |
| | 100mm | Each | 1148 |
| | 150mm | Each | 1837 |
| | 200mm | Each | 2641 |
| | 250mm | Each | 3674 |
| | 300mm | Each | 4823 |
| | 350mm | Each | 7706 |
| | 400mm | Each | 9633 |
| | 450mm | Each | 12110 |
| | 500mm | Each | 15138 |
| | 600mm | Each | 21881 |
| | 700mm | Each | 34072 |
| | 750mm | Each | 38591 |
| | 800mm | Each | 43111 |
| | 900mm | Each | 51629 |
| | 1000mm | Each | 64493 |
| 4.10 | Labour only for Laying including testing Ductile Iron PN 16 type flanged Spigot conforming to IS: 9523/2000 having dimension as per table 24 of IS: 9523/2000 in the following nominal diameter/sizes with external bitumen coating and internal cement mortar lining with finishing as per clause 13 of IS: 9523/2000. | | |
| | 100mm | Each | 21 |

| S. No. | Items | Unit | Rates in Rs. |
|---------------|--|-------------|---------------------|
| | 150mm | Each | 35 |
| | 200mm | Each | 50 |
| | 250mm | Each | 69 |
| | 300mm | Each | 90 |
| | 350mm | Each | 120 |
| | 400mm | Each | 150 |
| | 450mm | Each | 189 |
| | 500mm | Each | 236 |
| | 600mm | Each | 341 |
| | 700mm | Each | 421 |
| | 750mm | Each | 476 |
| | 800mm | Each | 532 |
| | 900mm | Each | 638 |
| | 1000mm | Each | 796 |
| 4.11 | Providing and Laying including testing Ductile iron Mechanical joint collar with follower glands conforming to IS: 9523/2000 having dimension as per table 24 of IS: 9523/2000 in the following nominal diameter/sizes with external bitumen and internal cement mortar lining. | | |
| | 100mm | Each | 2122 |
| | 150mm | Each | 3124 |
| | 200mm | Each | 4037 |
| | 250mm | Each | 6087 |
| | 300mm | Each | 7137 |
| | 350mm | Each | 11339 |
| | 400mm | Each | 13878 |
| | 450mm | Each | 15868 |
| | 500mm | Each | 18711 |
| | 600mm | Each | 23748 |
| | 700mm | Each | 44467 |
| | 750mm | Each | 49724 |
| | 800mm | Each | 56479 |
| | 900mm | Each | 66441 |
| | 1000mm | Each | 85648 |
| 4.12 | Labour only for Laying including testing Ductile Iron Mechanical Joint collar with follower glands conforming to IS: 9523/2000 having dimension as per table 24 of IS: 9523/2000 in the following nominal diameter /sizes with internal cement mortar lining. | | |
| | 100mm | Each | 47 |

| S. No. | Items | Unit | Rates in Rs. |
|---------------|---|-------------|---------------------|
| | 150mm | Each | 65 |
| | 200mm | Each | 82 |
| | 250mm | Each | 118 |
| | 300mm | Each | 137 |
| | 350mm | Each | 190 |
| | 400mm | Each | 222 |
| | 450mm | Each | 253 |
| | 500mm | Each | 295 |
| | 600mm | Each | 371 |
| | 700mm | Each | 557 |
| | 750mm | Each | 620 |
| | 800mm | Each | 701 |
| | 900mm | Each | 817 |
| | 1000mm | Each | 1021 |
| 4.13 | Providing and Laying including testing Ductile Iron Double Socket 90° Bends conforming to IS: 9523/2000 having dimension as per table 15 of IS: 9523/2000 in the following nominal diameter/sizes with external bitumen coating and internal cement mortar lining. | | |
| | 100mm | Each | 1145 |
| | 150 mm | Each | 2081 |
| | 200mm | Each | 3331 |
| | 250mm | Each | 4788 |
| | 300mm | Each | 6766 |
| | 350mm | Each | 11506 |
| | 400mm | Each | 14945 |
| | 450mm | Each | 19441 |
| | 500mm | Each | 24731 |
| | 600mm | Each | 33475 |
| | 700mm | Each | 51093 |
| | 750mm | Each | 63443 |
| | 800mm | Each | 68044 |
| | 900mm | Each | 90137 |
| | 1000mm | Each | 111988 |
| 4.14 | Labour only for Laying including testing Ductile Iron Double Socket 90° Bends conforming to IS: 9523/2000 having dimension as per table 15 of IS: 9523/2000 in the following nominal diameter/sizes with external bitumen coating and internal cement mortar lining. | | |

| S. No. | Items | Unit | Rates in Rs. |
|--------|---|------|--------------|
| | 100mm | Each | 23 |
| | 150 mm | Each | 43 |
| | 200mm | Each | 69 |
| | 250mm | Each | 99 |
| | 300mm | Each | 139 |
| | 350mm | Each | 187 |
| | 400mm | Each | 242 |
| | 450mm | Each | 315 |
| | 500mm | Each | 402 |
| | 600mm | Each | 611 |
| | 700mm | Each | 862 |
| | 750mm | Each | 1011 |
| | 800mm | Each | 1199 |
| | 900mm | Each | 1598 |
| | 1000mm | Each | 2068 |
| 4.15 | Providing and Laying including testing Ductile Iron Double Socket 45° Bends conforming to IS: 9523/2000 having dimension as per table 16 of IS: 9523/2000 in the following nominal diameter/sizes with external bitumen coating and internal cement mortar lining. | | |
| | 100mm | Each | 1041 |
| | 125mm | Each | 1353 |
| | 150 mm | Each | 1666 |
| | 200mm | Each | 2707 |
| | 250mm | Each | 3747 |
| | 300mm | Each | 5100 |
| | 350mm | Each | 8597 |
| | 400mm | Each | 10845 |
| | 450mm | Each | 14151 |
| | 500mm | Each | 17854 |
| | 600mm | Each | 26980 |
| | 700mm | Each | 46421 |
| | 750mm | Each | 53715 |
| | 800mm | Each | 63662 |
| | 900mm | Each | 84054 |
| | 1000mm | Each | 107927 |
| 4.16 | Labour only for Laying including testing Ductile Iron Double Socket 45° Bends conforming to IS: 9523/2000 having dimension as per table 16 of IS: 9523/2000 in the following nominal diameter/sizes with external bitumen coating and internal cement mortar lining. | | |

| S. No. | Items | Unit | Rates in Rs. |
|--------|---|------|--------------|
| | 100mm | Each | 21 |
| | 125mm | Each | 27 |
| | 150 mm | Each | 35 |
| | 200mm | Each | 56 |
| | 250mm | Each | 77 |
| | 300mm | Each | 105 |
| | 350mm | Each | 139 |
| | 400mm | Each | 176 |
| | 450mm | Each | 230 |
| | 500mm | Each | 290 |
| | 600mm | Each | 437 |
| | 700mm | Each | 601 |
| | 750mm | Each | 695 |
| | 800mm | Each | 824 |
| | 900mm | Each | 1088 |
| | 1000mm | Each | 1397 |
| 4.17 | Providing and Laying including testing Ductile Iron Double Socket 22.5° Bends conforming to IS: 9523/2000 having dimension as per table 17 of IS: 9523/2000 in the following nominal diameter/sizes with external bitumen coating and internal cement mortar lining. | | |
| | 100mm | Each | 936 |
| | 125mm | Each | 1249 |
| | 150 mm | Each | 1457 |
| | 200mm | Each | 2290 |
| | 250mm | Each | 3226 |
| | 300mm | Each | 4267 |
| | 350mm | Each | 6878 |
| | 400mm | Each | 8861 |
| | 450mm | Each | 11242 |
| | 500mm | Each | 14151 |
| | 600mm | Each | 20700 |
| | 700mm | Each | 35478 |
| | 750mm | Each | 40783 |
| | 800mm | Each | 48244 |
| | 900mm | Each | 62501 |
| | 1000mm | Each | 75930 |

| S. No. | Items | Unit | Rates in Rs. |
|--------|---|-------|--------------|
| 4.18 | Labour only for Laying including testing Ductile Iron Double Socket 22.5° Bends conforming to IS: 9523/2000 having dimension as per table 17 of IS: 9523/2000 in the following nominal diameter/sizes with external bitumen coating and internal cement mortar lining. | | |
| | 100mm | Each | 19 |
| | 125mm | Each | 25 |
| | 150 mm | Each | 31 |
| | 200mm | Each | 47 |
| | 250mm | Each | 66 |
| | 300mm | Each | 88 |
| | 350mm | Each | 112 |
| | 400mm | Each | 143 |
| | 450mm | Each | 182 |
| | 500mm | Each | 230 |
| | 600mm | Each | 337 |
| | 700mm | Each | 460 |
| | 750mm | Each | 528 |
| | 800mm | Each | 624 |
| 900mm | Each | 808 | |
| 1000mm | Each | 982 | |
| 4.19 | Providing and Laying including testing Ductile Iron Double Socket 11.25° bends conforming to IS:9523/2000 having dimension as per table 18 of IS:9523/2000 in the following nominal diameter/sizes with external bitumen coating and internal cement mortar lining | | |
| | 100mm | Each | 936 |
| | 125mm | Each | 1145 |
| | 150 mm | Each | 1353 |
| | 200mm | Each | 2186 |
| | 250mm | Each | 2914 |
| | 300mm | Each | 3852 |
| | 350mm | Each | 6083 |
| | 400mm | Each | 7538 |
| | 450mm | Each | 9654 |
| | 500mm | Each | 12035 |
| | 600mm | Each | 17589 |
| | 700mm | Each | 29179 |
| | 750mm | Each | 33323 |
| | 800mm | Each | 40120 |
| 900mm | Each | 53604 | |
| 1000mm | Each | 63662 | |

| S. No. | Items | Unit | Rates in Rs. |
|--------|--|------|--------------|
| 4.20 | Labour only for Laying including testing Ductile Iron Double Socket 11.25° bends conforming to IS:9523/2000 having dimension as per table 18 of IS:9523/2000 in the following nominal diameter /sizes with external bitumen coating and internal cement mortar lining. | | |
| | 100mm | Each | 19 |
| | 125mm | Each | 23 |
| | 150 mm | Each | 27 |
| | 200mm | Each | 45 |
| | 250mm | Each | 60 |
| | 300mm | Each | 79 |
| | 350mm | Each | 99 |
| | 400mm | Each | 122 |
| | 450mm | Each | 157 |
| | 500mm | Each | 195 |
| | 600mm | Each | 286 |
| | 700mm | Each | 377 |
| | 750mm | Each | 431 |
| | 800mm | Each | 520 |
| | 900mm | Each | 663 |
| | 1000mm | Each | 824 |
| 4.21 | Providing and Laying including testing Ductile Iron All socket Tees conforming to IS:9523/2000 having dimension as per table 21 of IS:9523/2000 in the following nominal diameter/sizes with external bitumen coating and internal cement mortar lining with finishing as per clause 13 of IS: 9523/2000. | | |
| | 100mm x 80mm | Each | 1457 |
| | 100mm x 100mm | Each | 1562 |
| | 150mm x 80mm | Each | 1978 |
| | 150mm x 100mm | Each | 2186 |
| | 150mm x 150mm | Each | 2498 |
| | 200mm x 80mm | Each | 2914 |
| | 200mm x 100mm | Each | 3123 |
| | 200mm x 150mm | Each | 3634 |
| | 200mm x 200mm | Each | 4164 |
| | 250mm x 80mm | Each | 3747 |
| | 250mm x 100mm | Each | 3955 |
| | 250mm x 150mm | Each | 4476 |

| S. No. | Items | Unit | Rates in Rs. |
|--------|---|------|--------------|
| | 250mm x 250mm | Each | 5725 |
| | 300mm x 100mm | Each | 5100 |
| | 300mm x 200mm | Each | 6454 |
| | 300mm x 300mm | Each | 8014 |
| 4.22 | Labour only for Laying including testing Ductile Iron All socket Tees conforming to IS:9523/2000 having dimension as per table 21 of IS:9523/2000 in the following nominal diameter/sizes with external bitumen coating and internal cement mortar lining. | | |
| | 100mm x 80mm | Each | 31 |
| | 100mm x 100mm | Each | 33 |
| | 150mm x 80mm | Each | 41 |
| | 150mm x 100mm | Each | 45 |
| | 150mm x 150mm | Each | 52 |
| | 200mm x 80mm | Each | 60 |
| | 200mm x 100mm | Each | 64 |
| | 200mm x 150mm | Each | 73 |
| | 200mm x 200mm | Each | 85 |
| | 250mm x 80mm | Each | 77 |
| | 250mm x 100mm | Each | 81 |
| | 250mm x 150mm | Each | 93 |
| | 250mm x 250mm | Each | 118 |
| | 300mm x 100mm | Each | 105 |
| | 300mm x 200mm | Each | 133 |
| | 300mm x 300mm | Each | 165 |
| 4.23 | Providing and Laying including testing Ductile Iron Double Socket branch flange Tee conforming to IS:9523/2000 having dimension as per table 21 of IS:9523/2000 in the following nominal diameter/sizes with external bitumen coating and internal cement mortar lining with finishing as per clause 13 of IS:9523/2000. | | |
| | 100mm x 80mm | Each | 1722 |
| | 100mm x 100mm | Each | 1837 |
| | 150mm x 80mm | Each | 2411 |
| | 150mm x 100mm | Each | 2526 |
| | 150mm x 150mm | Each | 3100 |

| S. No. | Items | Unit | Rates in Rs. |
|--------|--|------|--------------|
| | 200mm x 80mm | Each | 3330 |
| | 200mm x 100mm | Each | 3560 |
| | 200mm x 150mm | Each | 4133 |
| | 200mm x 200mm | Each | 4823 |
| | 250mm x 80mm | Each | 4248 |
| | 250mm x 100mm | Each | 4478 |
| | 250mm x 150mm | Each | 5166 |
| | 250mm x 200mm | Each | 5856 |
| | 250mm x 250mm | Each | 6774 |
| | 300mm x 80mm | Each | 5523 |
| | 300mm x 100mm | Each | 5741 |
| | 300mm x 150mm | Each | 6544 |
| | 300mm x 200mm | Each | 7348 |
| | 300mm x 250mm | Each | 8381 |
| | 300mm x 300mm | Each | 9529 |
| | 350mm x 100mm | Each | 8257 |
| | 350mm x 200mm | Each | 10321 |
| | 350mm x 350mm | Each | 14862 |
| | 400mm x 80mm | Each | 9359 |
| | 400mm x 100mm | Each | 9909 |
| | 400mm x 150mm | Each | 11147 |
| | 400mm x 200mm | Each | 12213 |
| | 400mm x 300mm | Each | 15275 |
| | 400mm x 400mm | Each | 19129 |
| | 450mm x 100mm | Each | 12248 |
| | 450mm x 250mm | Each | 16515 |
| | 500mm x 100mm | Each | 14725 |
| | 500mm x 200mm | Each | 17753 |
| | 500mm x 400mm | Each | 25597 |
| | 500mm x 500mm | Each | 31240 |
| | 600mm x 200mm | Each | 24497 |
| 4.24 | Labour only for Laying including testing Ductile Iron Double Socketed Branch Flange Tee Conforming to IS: 9523/2000 having dimension as per table 21 of IS:9523/2000 in the following nominal diameter/sizes with external bitumen coating and internal cement mortar lining. | | |
| | 100mm x 80mm | Each | 33 |
| | 100mm x 100mm | Each | 35 |
| | 150mm x 80mm | Each | 45 |

| S. No. | Items | Unit | Rates in Rs. |
|--------|--|------|--------------|
| | 150mm x 100mm | Each | 47 |
| | 150mm x 150mm | Each | 58 |
| | 200mm x 80mm | Each | 62 |
| | 200mm x 100mm | Each | 66 |
| | 200mm x 150mm | Each | 77 |
| | 200mm x 200mm | Each | 90 |
| | 250mm x 80mm | Each | 79 |
| | 250mm x 100mm | Each | 83 |
| | 250mm x 150mm | Each | 97 |
| | 250mm x 200mm | Each | 110 |
| | 250mm x 250mm | Each | 126 |
| | 300mm x 80mm | Each | 103 |
| | 300mm x 100mm | Each | 108 |
| | 300mm x 150mm | Each | 122 |
| | 300mm x 200mm | Each | 137 |
| | 300mm x 250mm | Each | 157 |
| | 300mm x 300mm | Each | 178 |
| | 350mm x 100mm | Each | 129 |
| | 350mm x 200mm | Each | 161 |
| | 350mm x 350mm | Each | 232 |
| | 400mm x 80mm | Each | 145 |
| | 400mm x 100mm | Each | 155 |
| | 400mm x 150mm | Each | 174 |
| | 400mm x 200mm | Each | 191 |
| | 400mm x 300mm | Each | 238 |
| | 400mm x 400mm | Each | 298 |
| | 450mm x 100mm | Each | 191 |
| | 450mm x 250mm | Each | 257 |
| | 500mm x 100mm | Each | 230 |
| | 500mm x 200mm | Each | 277 |
| | 500mm x 400mm | Each | 399 |
| | 500mm x 500mm | Each | 487 |
| | 600mm x 200mm | Each | 382 |
| 4.25 | Providing and Laying including testing Ductile Iron Double Socket Reducer conforming to IS: 9523/2000 having dimension as per table 21 of IS: 9523/2000 in the following nominal diameter/sizes with external bitumen coating and internal cement mortar lining with finishing as per clause 13 of IS: 9523/2000. | | |
| | 100mm x 80mm | Each | 837 |
| | 150mm x 80mm | Each | 1355 |
| | 150mm x 100mm | Each | 1353 |
| | 200mm x 100mm | Each | 2077 |

| S. No. | Items | Unit | Rates in Rs. |
|--------|---|------|--------------|
| | 200mm x 150mm | Each | 1984 |
| | 250mm x 150mm | Each | 2810 |
| | 300mm x 150mm | Each | 3840 |
| | 300mm x 200mm | Each | 3951 |
| | 300mm x 250mm | Each | 3653 |
| | 350mm x 200mm | Each | 6480 |
| | 350mm x 250mm | Each | 6218 |
| | 350mm x 300mm | Each | 5967 |
| | 400mm x 250mm | Each | 8201 |
| | 400mm x 300mm | Each | 7807 |
| | 400mm x 350mm | Each | 7300 |
| | 450mm x 350mm | Each | 9658 |
| | 450mm x 400mm | Each | 9155 |
| | 500mm x 350mm | Each | 12462 |
| | 500mm x 400mm | Each | 11863 |
| | 600mm x 400mm | Each | 18417 |
| | 600mm x 500mm | Each | 17192 |
| 4.26 | Labour only for laying including testing ductile iron double socket reducer conforming to IS: 9523/2000 having dimension as per table 20 of IS: 9523/2000 in the following nominal diameter/sizes with external bitumen coating and internal cement mortar lining with finishing as per clause 13 of IS: 9523/2000 | | |
| | 100mm x 80mm | Each | 21 |
| | 150mm x 80mm | Each | 31 |
| | 150mm x 100mm | Each | 27 |
| | 200mm x 100mm | Each | 39 |
| | 200mm x 150mm | Each | 47 |
| | 250mm x 150mm | Each | 58 |
| | 300mm x 150mm | Each | 69 |
| | 300mm x 200mm | Each | 77 |
| | 300mm x 250mm | Each | 85 |
| | 350mm x 200mm | Each | 105 |
| | 350mm x 250mm | Each | 103 |
| | 350mm x 300mm | Each | 112 |
| | 400mm x 250mm | Each | 135 |
| | 400mm x 300mm | Each | 131 |
| | 400mm x 350mm | Each | 143 |
| | 450mm x 350mm | Each | 161 |
| | 450mm x 400mm | Each | 178 |
| | 500mm x 350mm | Each | 232 |

| S. No. | Items | Unit | Rates in Rs. |
|--------|--|------|--------------|
| | 500mm x 400mm | Each | 284 |
| | 600mm x 400mm | Each | 332 |
| | 600mm x 500mm | Each | 408 |
| 4.27 | Providing, Laying including testing and Jointing of welded double flanged centrifugal cast (spun) ductile Iron pressure pipes conforming to IS: 8329/2000 in the length of 1 m. for class K-9 with inside cement mortar lining for the following sizes/dia pipes. | | |
| | 100mm Dia | Each | 3098 |
| | 150mm Dia | Each | 4041 |
| | 200mm Dia | Each | 5322 |
| | 250mm Dia | Each | 6776 |
| | 300mm Dia | Each | 8262 |
| | 350mm Dia | Each | 10415 |
| | 400mm Dia | Each | 12716 |
| | 450mm Dia | Each | 17162 |
| | 500mm Dia | Each | 19274 |
| | 600mm Dia | Each | 25492 |
| | 700mm Dia | Each | 31810 |
| | 750mm Dia | Each | 36992 |
| | 800mm Dia | Each | 39029 |
| | 900mm Dia | Each | 47834 |
| | 1000mm Dia | Each | 57714 |
| 4.28 | Providing, Laying including testing and Jointing of welded double flanged centrifugal cast (spun) ductile Iron pressure pipes conforming to IS:8329/2000 in the length of 2m. for class K-9 with inside cement mortar, lining for the following sizes/dia pipes. | | |
| | 100mm Dia | Each | 5612 |
| | 150mm Dia | Each | 7480 |
| | 200mm Dia | Each | 9960 |
| | 250mm Dia | Each | 12851 |
| | 300mm Dia | Each | 15581 |
| | 350mm Dia | Each | 19858 |
| | 400mm Dia | Each | 24150 |
| | 450mm Dia | Each | 32523 |
| | 500mm Dia | Each | 36389 |
| | 600mm Dia | Each | 48541 |

| S. No. | Items | Unit | Rates in Rs. |
|--------|---|------|--------------|
| 4.29 | Providing , Laying including testing and Jointing of welded double flanged centrifugal cast (spun) ductile Iron pressure pipes conforming to IS:8329/2000 in the length of 3 m for class K-9 with inside cement mortar, lining for the following sizes/dia pipes | | |
| | 100mm Dia | Each | 8189 |
| | 150mm Dia | Each | 10985 |
| | 200mm Dia | Each | 14666 |
| | 250mm Dia | Each | 18994 |
| | 300mm Dia | Each | 23018 |
| | 350mm Dia | Each | 29373 |
| | 400mm Dia | Each | 35657 |
| | 450mm Dia | Each | 47958 |
| | 500mm Dia | Each | 53580 |
| | 600mm Dia | Each | 71668 |
| 4.30 | Providing, Laying including testing and Jointing welded double flanged centrifugal cast (spun) ductile Iron pressure pipes conforming to IS 8329/2000 in the length of 4m for class K-9 with inside cement mortar lining for the following sizes/dia pipes. | | |
| | 100mm Dia | Each | 10767 |
| | 150mm Dia | Each | 14491 |
| | 200mm Dia | Each | 19371 |
| | 250mm Dia | Each | 25137 |
| | 300mm Dia | Each | 30455 |
| | 350mm Dia | Each | 38887 |
| | 400mm Dia | Each | 47164 |
| | 450mm Dia | Each | 63393 |
| | 500mm Dia | Each | 70772 |
| | 600mm Dia | Each | 94796 |
| 4.31 | Providing, Laying including testing and Jointing welded double flanged centrifugal cast (spun) ductile Iron pressure pipes conforming to IS:8329/2000 in the length of 4.5 m. for class K-9 with inside cement mortar lining for the following sizes/dia pipes. | | |
| | 100mm Dia | Each | 12055 |
| | 150mm Dia | Each | 16243 |
| | 200mm Dia | Each | 21724 |
| | 250mm Dia | Each | 28209 |

| S. No. | Items | Unit | Rates in Rs. |
|--------|--|------|--------------|
| | 300mm Dia | Each | 34050 |
| | 350mm Dia | Each | 43645 |
| | 400mm Dia | Each | 52918 |
| | 450mm Dia | Each | 71111 |
| | 500mm Dia | Each | 79367 |
| | 600mm Dia | Each | 106360 |
| 4.32 | Providing, Laying including testing and Jointing welded double flanged centrifugal cast (spun) ductile Iron pressure pipes conforming to IS: 8329/2000 in the length of 5m. for class K-9 with inside cement mortar lining for the following sizes/dia pipes. | | |
| | 100mm Dia | Each | 13344 |
| | 150mm Dia | Each | 17996 |
| | 200mm Dia | Each | 24077 |
| | 250mm Dia | Each | 31280 |
| | 300mm Dia | Each | 37892 |
| | 350mm Dia | Each | 48401 |
| | 400mm Dia | Each | 58671 |
| | 450mm Dia | Each | 78829 |
| | 500mm Dia | Each | 87963 |
| | 600mm Dia | Each | 117924 |
| 4.33 | Providing, Laying including testing and Jointing of welded double flanged centrifugal cast (spun) ductile Iron pressure pipes conforming to IS: 8329/2000 in the length of 5.2m. for class K-9 with inside cement mortar lining for the following sizes/dia pipes | | |
| | 100mm Dia | Each | 32509 |
| | 150mm Dia | Each | 39222 |
| | 200mm Dia | Each | 50305 |
| | 250mm Dia | Each | 60973 |
| | 300mm Dia | Each | 81916 |
| | 350mm Dia | Each | 91400 |
| | 400mm Dia | Each | 122551 |
| | 450mm Dia | Each | 32509 |
| | 500mm Dia | Each | 39222 |
| | 600mm Dia | Each | 50305 |
| 4.34 | Labour only for Laying including testing welded double flanged centrifugal cast (spun) ductile Iron pressure pipes conforming to IS: 8329/2000 in the length of 1m. for class K-9 with inside cement mortar lining for the following sizes/dia pipes | | |
| | 100mm Dia | Each | 54 |
| | 150mm Dia | Each | 85 |

| S. No. | Items | Unit | Rates in Rs. |
|--------|---|------|--------------|
| | 200mm Dia | Each | 116 |
| | 250mm Dia | Each | 155 |
| | 300mm Dia | Each | 197 |
| | 350mm Dia | Each | 242 |
| | 400mm Dia | Each | 290 |
| | 450mm Dia | Each | 339 |
| | 500mm Dia | Each | 397 |
| | 600mm Dia | Each | 530 |
| 4.35 | Labour only for Laying including testing welded double flanged centrifugal cast (spun) ductile Iron pressure pipes conforming to IS: 8329/2000 in the length of 2m. for class K-9 with inside cement mortar lining for the following sizes/dia pipes. | | |
| | 100mm Dia | Each | 93 |
| | 150mm Dia | Each | 150 |
| | 200mm Dia | Each | 201 |
| | 250mm Dia | Each | 270 |
| | 300mm Dia | Each | 346 |
| | 350mm Dia | Each | 425 |
| | 400mm Dia | Each | 508 |
| | 450mm Dia | Each | 599 |
| | 500mm Dia | Each | 700 |
| | 600mm Dia | Each | 929 |
| 4.36 | Labour only for Laying including testing welded double flanged centrifugal cast (spun) ductile Iron pressure pipes conforming to IS: 8329/2000 in the length of 3m. for class K-9 with inside cement mortar, lining for the following sizes/dia pipes. | | |
| | 100mm Dia | Each | 131 |
| | 150mm Dia | Each | 215 |
| | 200mm Dia | Each | 288 |
| | 250mm Dia | Each | 386 |
| | 300mm Dia | Each | 543 |
| | 350mm Dia | Each | 607 |
| | 400mm Dia | Each | 727 |
| | 450mm Dia | Each | 858 |
| | 500mm Dia | Each | 1002 |
| | 600mm Dia | Each | 1328 |

| S. No. | Items | Unit | Rates in Rs. |
|-----------|---|------|--------------|
| 4.37 | Labour only for Laying including testing welded double flanged centrifugal cast (spun) ductile Iron pressure pipes conforming to IS: 8329/2000 in the length of 4m. for class K-9 with inside cement mortar, lining for the following sizes/dia pipes. | | |
| | 100mm Dia | Each | 170 |
| | 150mm Dia | Each | 279 |
| | 200mm Dia | Each | 373 |
| | 250mm Dia | Each | 502 |
| | 300mm Dia | Each | 740 |
| | 350mm Dia | Each | 789 |
| | 400mm Dia | Each | 947 |
| | 450mm Dia | Each | 1117 |
| | 500mm Dia | Each | 1305 |
| 600mm Dia | Each | 1728 | |
| 4.38 | Labour only for Laying including testing and Jointing welded double flanged centrifugal cast (spun) ductile Iron pressure pipes conforming to IS: 8329/2000 in the length of 4.5m. for class K-9 with inside cement mortar, lining for the following sizes/dia pipe. | | |
| | 100mm Dia | Each | 189 |
| | 150mm Dia | Each | 311 |
| | 200mm Dia | Each | 416 |
| | 250mm Dia | Each | 560 |
| | 300mm Dia | Each | 716 |
| | 350mm Dia | Each | 881 |
| | 400mm Dia | Each | 1055 |
| | 450mm Dia | Each | 1248 |
| | 500mm Dia | Each | 1456 |
| 600mm Dia | Each | 1927 | |
| 4.39 | Labour only for Laying including testing welded double flanged centrifugal cast (spun) ductile Iron pressure pipes conforming to IS: 8329/2000 in the length of 5m. for class K-9 with inside cement mortar lining for the following sizes/dia pipes. | | |
| | 100mm Dia | Each | 208 |
| | 150mm Dia | Each | 344 |
| | 200mm Dia | Each | 460 |
| | 250mm Dia | Each | 618 |
| | 300mm Dia | Each | 937 |
| | 350mm Dia | Each | 972 |

| S. No. | Items | Unit | Rates in Rs. |
|--------|---|------|--------------|
| | 400mm Dia | Each | 1165 |
| | 450mm Dia | Each | 1378 |
| | 500mm Dia | Each | 1607 |
| | 600mm Dia | Each | 2126 |
| 4.40 | Labour only for Laying including testing welded double flanged centrifugal cast (spun) ductile Iron pressure pipes conforming to IS: 8329/2000 in the length of 5.2m for class K-9 with inside cement mortar lining for the following sizes/dia pipes. | | |
| | 100mm Dia | Each | 216 |
| | 150mm Dia | Each | 356 |
| | 200mm Dia | Each | 476 |
| | 250mm Dia | Each | 641 |
| | 300mm Dia | Each | 820 |
| | 350mm Dia | Each | 1009 |
| | 400mm Dia | Each | 1209 |
| | 450mm Dia | Each | 1430 |
| | 500mm Dia | Each | 1668 |
| | 600mm Dia | Each | 2206 |

DUCTILE IRON VALVES

| S. No. | Item | Unit | Rates inRs. | |
|--------|---|------|---------------------|---------------------|
| 4.41 | Providing & fixing of following Ductile iron double flanged sluice valves as per I.S.:14846-2000 fitted with cap including jointing & testing with cost of jointing material such as bolts, nuts, rubber insertions etc. all complete. | | CLASS PN- 10 | CLASS PN- 16 |
| | 80mm dia | Each | 6595 | 6913 |
| | 100mm dia | Each | 8863 | 9289 |
| | 150mm dia | Each | 13519 | 12187 |
| | 200mm dia | Each | 22008 | 22330 |
| | 250mm dia | Each | 31438 | 41817 |
| | 300mm dia | Each | 49350 | 55115 |
| | 350mm dia | Each | 72456 | 86515 |
| | 400mm dia | Each | 109242 | 109242 |
| | 450mm dia | Each | 153699 | 153699 |
| | 500mm dia | Each | 205360 | 205360 |

| S. No. | Item | Unit | Rates inRs. | |
|------------|---|------|--------------------------|--------------------|
| 4.42 | Fixing of following Ductile iron double flanged sluice valves fitted with cap testing with cost of jointing material such as bolts, nuts, rubber insertions etc. all complete (only valve to be supplied by deptt. free of cost. | | CLASS PN-10/PN-16 | |
| | 80mm dia | Each | 229 | |
| | 100mm dia | Each | 358 | |
| | 150mm dia | Each | 520 | |
| | 200mm dia | Each | 718 | |
| | 250mm dia | Each | 1160 | |
| | 300mm dia | Each | 1312 | |
| | 350 mm dia | Each | 2164 | |
| | 400 mm dia | Each | 3322 | |
| | 450 mm dia | Each | 4019 | |
| 500 mm dia | Each | 5074 | | |
| 4.43 | Labour for laying and fixing of following ductile iron double flanged sluice valves (vide item no.1) including jointing and testing but without cost of Jointing materials. | | CLASS PN-10/PN-16 | |
| | 80mm dia | Each | 109 | |
| | 100mm dia | Each | 150 | |
| | 150mm dia | Each | 220 | |
| | 200mm dia | Each | 328 | |
| | 250mm dia | Each | 472 | |
| | 300mm dia | Each | 609 | |
| | 350 mm dia | Each | 1064 | |
| | 400 mm dia | Each | 1258 | |
| | 450 mm dia | Each | 1504 | |
| 500 mm dia | Each | 1820 | | |
| 4.44 | Providing & fixing following ductile iron double flanged check valvewithout damper (non-returnvalve) including jointing &testing with cost of jointing material such as bolts,nuts and rubber insertion all complete as per IS: 5312 (Part II) | | CLASS PN- 10 | CLASS PN-16 |
| | 200mm dia | Each | 21842 | 22163 |
| | 250mm dia | Each | 31061 | 41439 |
| | 300mm dia | Each | 49281 | 58888 |
| | 350 mm dia | Each | 72111 | 86169 |
| | 400 mm dia | Each | 108659 | 108659 |
| | 500 mm dia | Each | 205466 | 205466 |
| | 600 mm dia | Each | 320491 | 320491 |
| 4.45 | Labour for laying and fixing of following ductile iron double flanged check valve without damper (non-return valve) including jointing & testing with cost of jointing material such as bolts, nuts and | | CLASS PN-10/PN-16 | |

| S. No. | Item | Unit | Rates inRs. | |
|--------|--|------|--------------------------|--------------------|
| | rubber insertion all complete as per IS : 5312 (Part II) | | | |
| | 200mm dia | Each | 551 | |
| | 250mm dia | Each | 783 | |
| | 300mm dia | Each | 1243 | |
| | 350 mm dia | Each | 1818 | |
| | 400 mm dia | Each | 2739 | |
| | 500 mm dia | Each | 5180 | |
| | 600 mm dia | Each | 8079 | |
| 4.46 | Labour for laying and fixing of following ductile iron double flanged check valve without damper (non-return valve)excluding jointing & testing with cost of jointing material such as bolts,nuts and rubber insertion all complete as per IS: 5312 (Part II) | | CLASS PN-10/PN-16 | |
| | 200mm dia | Each | 209 | |
| | 250mm dia | Each | 343 | |
| | 300mm dia | Each | 435 | |
| | 350 mm dia | Each | 668 | |
| | 400 mm dia | Each | 870 | |
| | 500 mm dia | Each | 1223 | |
| | 600 mm dia | Each | 1860 | |
| 4.47 | Providing & fixing following ductile iron butterfly valves including jointing & testing with cost of jointing material such as bolts, nuts and rubber insertion all complete as per IS: 13095-1991. | | CLASS PN- 10 | CLASS PN-16 |
| | 100mm dia | Each | 6406 | 8073 |
| | 150mm dia | Each | 7504 | 9444 |
| | 200mm dia | Each | 10145 | 12768 |
| | 250mm dia | Each | 14956 | 20678 |
| | 300mm dia | Each | 17946 | 26694 |
| | 350mm dia | Each | 50478 | 63520 |
| | 400mm dia | Each | 60209 | 75769 |
| | 450mm dia | Each | 71117 | 89578 |
| | 500mm dia | Each | 98344 | 123746 |
| 4.48 | Labour for laying and fixing of following ductile iron butterfly valves including jointing & testing but without cost of jointing materials. | | CLASS PN-10/PN-16 | |
| | 100mm dia | Each | 120 | |
| | 150mm dia | Each | 138 | |
| | 200mm dia | Each | 169 | |
| | 250mm dia | Each | 209 | |
| | 300mm dia | Each | 343 | |
| | 350mm dia | Each | 492 | |
| | 400mm dia | Each | 587 | |

| S. No. | Item | Unit | Rates inRs. | |
|--------|--|------|--------------------------|---------------------|
| | 450mm dia | Each | 693 | |
| | 500mm dia | Each | 959 | |
| 4.49 | Labour for laying and fixing of following Ductile Iron butterfly valves including jointing & testing but with cost of jointing materials. | | CLASS PN-10/PN-16 | |
| | 100mm dia | Each | 162 | |
| | 150mm dia | Each | 189 | |
| | 200mm dia | Each | 256 | |
| | 250mm dia | Each | 377 | |
| | 300mm dia | Each | 452 | |
| | 350mm dia | Each | 1273 | |
| | 400mm dia | Each | 1518 | |
| | 450mm dia | Each | 1793 | |
| | 500mm dia | Each | 2479 | |
| 4.50 | Providing & fixing following ductile iron single chamber triple function temper proof air valves, small orifice with screwed end as per IS : 14845-2000 including jointing & testing with cost of jointing material and rubber insertion all complete as per IS :13095-1991 | | CLASS PN- 10 | CLASS PN- 16 |
| | 50mm dia | Each | 6240 | 6544 |
| | 80mm dia | Each | 6531 | 6849 |
| | 100mm dia | Each | 8726 | 9151 |
| | 150mm dia | Each | 11969 | 11969 |
| 4.51 | Labour for laying and fixing of following ductile iron single chamber triple function temper proof air valves small orifice with screwed end i/c jointing & testing but without cost of jointing material. | | CLASS PN-10/PN-16 | |
| | 50mm dia | Each | 61 | |
| | 80mm dia | Each | 87 | |
| | 100mm dia | Each | 120 | |
| | 150mm dia | Each | 138 | |
| 4.52 | Labour for laying and fixing of following ductile iron single chamber triple function temper proof Air valves small orifice with screwed end i/c jointing & testing but with cost of jointing material. | | CLASS PN-10/PN-16 | |
| | 50mm dia | Each | 158 | |
| | 80mm dia | Each | 165 | |
| | 100mm dia | Each | 220 | |
| | 150mm dia | Each | 302 | |

DUCTILE IRON SOFT SEATED VALVES

| S. No. | Item | Unit | Rates inRs. | |
|--------|---|------|-------------------------|-------------------------|
| 4.53 | <p>Providing & fixing of following Ductile iron double flanged sluice valves glandless, resilient (soft seated) non-rising spindle with body bonnet of ductile cast iron of grade GGG 40/SGI 400/12 or equivalent grade or of higher tensile strength grade, as per IS: 3896 part-II-1986 and subsequent revision, wedge fully rubber lined with EPDM food grade quality and seals of NBR. The valve should be with replaceable nut and replaceable sliding shoes, valve stems shall be of single piece thread rolled. Sluice valve shall be compatible for buried applications without valve chambers. The valve should be vacuum tight and 100% leakproof with face to face dimensions as BS: 5163-89/ IS: 14846/2000/DIN 3204 F4 and flange connections as per IS: 1538. Valve should be with electrostatic powder coating both inside and outside (thickness 250 micron) with pocketless straight through body passage including jointing and testing with cost of jointing material such as bolts, nuts, rubber insertions etc. all complete.</p> | | CLASS PN- 10 | CLASS PN- 16 |
| | 100mm dia | Each | 11981 | 11981 |
| | 150mm dia | Each | 17507 | 17507 |
| | 200mm dia | Each | 27718 | 27718 |
| | 250mm dia | Each | 55826 | 55826 |
| | 300mm dia | Each | 76742 | 76742 |
| | 350mm dia | Each | 134116 | 167123 |
| | 400mm dia | Each | 170131 | 212227 |
| | 450mm dia | Each | 209706 | 262180 |
| | 500mm dia | Each | 263596 | 328988 |
| | 600mm dia | Each | 390402 | 487625 |

CHAPTER – V

ASBESTOS CEMENT PRESSURE PIPES

AND

CAST IRON FITTINGS

Chapter – V

ASBESTOS CEMENT PRESSURE PIPES AND CAST IRON FITTINGS

NOTES:

1. The A.C.P. pipes shall be confirming to IS -1592:2003
2. Pipes shall be tested in the factory as per IS 5913:1970
3. The laying of A.C.P pipes shall be done as per IS - 6530:1972
4. C.I. specials for A.C.P. pipes shall be done as per IS -5531:1988
5. The C.I.D. joints shall be confirming to IS -8794:1988
6. The rubber sealing of the D. Joint shall be confirming to IS -10292:1988
7. All measurements shall be of the finishedwork.
8. Work shall be executed in accordance with the Indian Standards Specifications and special notes if any, covered in the agreement of thework.
9. **This USOR contains the rates of all the items without GST. No claims against GST shall be entertained at any level. GST shall be paid by the Agency/ Contractor directly to the concerning department. Howerer, All the estimates prepared on this USOR will include GST, as an extra amount as per prevailing rates on the sum of the estimate to arrive at the gross amount.**

ASBESTOS CEMENT PRESSURE PIPES AND CAST IRON FITTINGS

| Item No. | Items | Unit | Rate in Rupees | | |
|----------|--|------|----------------|----------|----------|
| | | | Class 15 | Class 20 | Class 25 |
| 5.1 | Providing, laying and jointing of following Asbestos cement pressure pipe ISI marked and conforming to IS:1592/03 tested to the required pressure including testing of joints, cost of pipes & detachable joint ISI markedconforming to IS: 8794/1988 all complete manufactured by mazza process. | | | | |
| | 80mm Dia | Mtr. | 270 | 301 | 339 |
| | 100mm Dia | Mtr. | 357 | 437 | 528 |
| | 125 mm Dia | Mtr. | 467 | 563 | 689 |
| | 150mm Dia | Mtr. | 634 | 771 | 950 |
| | 200mm Dia | Mtr. | 1036 | 1298 | 1609 |
| | 250mm Dia | Mtr. | 1344 | 1758 | 2074 |
| | 300mm Dia | Mtr. | 1829 | 2331 | 2908 |
| | 350 mm Dia | Mtr. | 2360 | 2960 | 3607 |

| Item No. | Items | Unit | Rate in Rupees | | |
|----------|---|------|----------------|------|------|
| 5.2 | Providing, laying and jointing of following Asbestos cement pressure pipe with A.C. coupler Joint ISI marked and conforming to IS:1592/03 tested to the required pressure including testing of joints, cost of pipes all complete manufactured by mazza process. | | | | |
| | 80mm Dia | Mtr. | 367 | 387 | 356 |
| | 100mm Dia | Mtr. | 493 | 577 | 673 |
| | 125 mm Dia | Mtr. | 613 | 709 | 840 |
| | 150mm Dia | Mtr. | 714 | 841 | 1008 |
| | 200mm Dia | Mtr. | 1086 | 1312 | 1607 |
| | 250mm Dia | Mtr. | 1398 | 1719 | 2088 |
| | 300mm Dia | Mtr. | 1856 | 2328 | 2892 |
| | 350 mm Dia | Mtr. | 2323 | 2932 | 3596 |
| 5.3 | Labour for laying in position including testing following Asbestos cement pressure pipes class 15,20,25. | | | | |
| | 80mm Dia | Mtr. | 7 | 7 | 7 |
| | 100mm Dia | Mtr. | 8 | 8 | 8 |
| | 125 mm Dia | Mtr. | 11 | 11 | 11 |
| | 150mm Dia | Mtr. | 13 | 13 | 13 |
| | 200mm Dia | Mtr. | 21 | 21 | 21 |
| | 250mm Dia | Mtr. | 27 | 27 | 27 |
| | 300mm Dia | Mtr. | 36 | 36 | 36 |
| | 350 mm Dia | Mtr. | 44 | 44 | 44 |
| 5.4 | Providing detachable joints to following asbestos cement pressure pipes and fittings including C.I. detachable joints confirming to IS/8794/1988 with bolts, nuts and rubber rings confirming to IS: 5382/85 & IS: 10292/1988 manufactured by mazza process including testing. | | | | |
| | 80mm Dia | Each | 299 | 323 | 347 |
| | 100mm Dia | Each | 366 | 401 | 413 |
| | 125 mm Dia | Each | 483 | 514 | 548 |
| | 150mm Dia | Each | 561 | 605 | 659 |
| | 200mm Dia | Each | 761 | 875 | 929 |
| | 250mm Dia | Each | 1014 | 1167 | 1242 |
| | 300mm Dia | Each | 1229 | 1448 | 1542 |
| | 350 mm Dia | Each | 1880 | 1883 | 1885 |

| Item No. | Items | Unit | Rate in Rupees | | |
|----------|--|------|----------------|------|------|
| 5.5 | Labour for providing detachable joints to following asbestos cement pressure pipes and fittings class 15, 20 & 25 including testing of joints but excluding cost of C.I. Detachable joints. | | | | |
| | 80mm Dia | Each | 87 | 89 | 93 |
| | 100mm Dia | Each | 103 | 105 | 108 |
| | 125 mm Dia | Each | 118 | 120 | 123 |
| | 150mm Dia | Each | 133 | 135 | 138 |
| | 200mm Dia | Each | 148 | 150 | 154 |
| | 250mm Dia | Each | 164 | 167 | 169 |
| | 300mm Dia | Each | 179 | 182 | 184 |
| | 350 mm Dia | Each | 194 | 197 | 199 |
| 5.6 | Providing A.C. Coupler joints to following A.C. pressure pipes confirming to IS specification including testing of joints rubber ring complete manufactured by mazza process. | | | | |
| | 80mm Dia | Each | 140 | 148 | 163 |
| | 100mm Dia | Each | 148 | 157 | 176 |
| | 125 mm Dia | Each | 238 | 264 | 319 |
| | 150mm Dia | Each | 367 | 442 | 532 |
| | 200mm Dia | Each | 390 | 489 | 625 |
| | 250mm Dia | Each | 568 | 774 | 877 |
| | 300mm Dia | Each | 896 | 1227 | 1550 |
| | 350 mm Dia | Each | 2236 | 2301 | 2365 |
| 5.7 | Labour for providing A.C. Coupler joint for the following asbestos cement pressure pipes and fittings class 15, 20 & 25 including testing of joint but excluding cost of A.C. Coupler and rubber rings. | | | | |
| | 80mm Dia | Each | 69 | 71 | 74 |
| | 100mm Dia | Each | 82 | 84 | 87 |
| | 125 mm Dia | Each | 95 | 95 | 98 |
| | 150mm Dia | Each | 105 | 108 | 110 |
| | 200mm Dia | Each | 118 | 120 | 123 |
| | 250mm Dia | Each | 130 | 133 | 135 |
| | 300mm Dia | Each | 143 | 145 | 148 |
| | 350 mm Dia | Each | 154 | 154 | 154 |
| 5.8 | Providing & laying in position including testing following cast iron plain ended standard specials confirming to IS/5531/1988 (Reaffirmed 2002). | | | | |

| Item No. | Items | Unit | Rate in Rupees | | |
|----------|---------------------------------|------|-----------------|-----------------|-----------------|
| | | | Class 15 | Class 20 | Class 25 |
| (i) | Cast Iron Plain ended 90° Bend | | Class 15 | Class 20 | Class 25 |
| | 80mm Dia | Each | 554 | 634 | 715 |
| | 100mm Dia | Each | 773 | 948 | 1072 |
| | 125 mm Dia | Each | 1079 | 1313 | 1488 |
| | 150mm Dia | Each | 1531 | 1874 | 2107 |
| | 200mm Dia | Each | 2661 | 3259 | 3682 |
| | 250mm Dia | Each | 3893 | 4768 | 5278 |
| | 300mm Dia | Each | 5687 | 6984 | 7728 |
| | 350 mm Dia | Each | 7655 | 9332 | 10862 |
| (ii) | Cast Iron Plain ended 45° Bend | | Class 15 | Class 20 | Class 25 |
| | 80mm Dia | Each | 561 | 642 | 722 |
| | 100mm Dia | Each | 759 | 933 | 1057 |
| | 125 mm Dia | Each | 1021 | 1254 | 1421 |
| | 150mm Dia | Each | 1429 | 1743 | 1976 |
| | 200mm Dia | Each | 2376 | 2930 | 3346 |
| | 250mm Dia | Each | 3339 | 4119 | 4629 |
| | 300mm Dia | Each | 4753 | 5883 | 6663 |
| | 350 mm Dia | Each | 6197 | 7655 | 8967 |
| (iii) | Cast Iron Plain ended 22½° Bend | | Class 15 | Class 20 | Class 25 |
| | 80mm Dia | Each | 416 | 474 | 554 |
| | 100mm Dia | Each | 561 | 700 | 816 |
| | 125 mm Dia | Each | 743 | 926 | 1094 |
| | 150mm Dia | Each | 1049 | 1297 | 1531 |
| | 200mm Dia | Each | 1750 | 2187 | 2610 |
| | 250mm Dia | Each | 2384 | 2996 | 3507 |
| | 300mm Dia | Each | 3383 | 4264 | 5045 |
| | 350 mm Dia | Each | 4301 | 5432 | 6554 |
| (iv) | Cast Iron Plain ended 11¼° Bend | | Class 15 | Class 20 | Class 25 |
| | 80mm Dia | Each | 343 | 386 | 467 |
| | 100mm Dia | Each | 460 | 584 | 700 |
| | 125 mm Dia | Each | 605 | 759 | 926 |
| | 150mm Dia | Each | 860 | 1072 | 1305 |
| | 200mm Dia | Each | 1436 | 1823 | 2245 |
| | 250mm Dia | Each | 1902 | 2435 | 2946 |
| | 300mm Dia | Each | 2698 | 3463 | 4236 |
| | 350 mm Dia | Each | 3360 | 4323 | 5329 |
| (v) | Cast Iron Plain ended Tees | | | | |
| | Body & Branch | | Class 15 | Class 20 | Class 25 |
| | 80x80mm | Each | 707 | 809 | 933 |
| | 100x80mm | Each | 918 | 1057 | 1196 |
| | 100x100mm | Each | 1014 | 1254 | 1436 |
| | 125X80mm | Each | 1166 | 1385 | 1553 |
| | 125X100mm | Each | 1290 | 1647 | 1852 |
| | 125X125mm | Each | 1451 | 1778 | 2026 |

| Item No. | Items | Unit | Rate in Rupees | | |
|----------|---|------|-----------------|-----------------|-----------------|
| | 150x80mm | Each | 1764 | 2136 | 2406 |
| | 150x100mm | Each | 1844 | 2260 | 2552 |
| | 150X125mm | Each | 1946 | 2384 | 2705 |
| | 150x150mm | Each | 2121 | 2596 | 2939 |
| | 200X80 mm | Each | 3018 | 3702 | 4141 |
| | 200X100 mm | Each | 3105 | 3806 | 4287 |
| | 200X125mm | Each | 3215 | 3937 | 4447 |
| | 200X150 mm | Each | 3448 | 4156 | 4687 |
| | 200X200 mm | Each | 3799 | 4666 | 5301 |
| | 250X80 mm | Each | 4462 | 4710 | 5986 |
| | 250X100 mm | Each | 4549 | 5570 | 6138 |
| | 250X125mm | Each | 4673 | 5715 | 6313 |
| | 250X150 mm | Each | 4855 | 5942 | 6568 |
| | 250X200 mm | Each | 5285 | 6474 | 7196 |
| | 250X250 mm | Each | 5679 | 6977 | 7728 |
| (vi) | Cast Iron Plain ended Tees 300x80 to 350x350mm | | | | |
| | Body & Branch | | Class 15 | Class 20 | Class 25 |
| | 300X80mm | Each | 6568 | 8019 | 8822 |
| | 300X100mm | Each | 6656 | 8165 | 8967 |
| | 300X125mm | Each | 6787 | 8311 | 9186 |
| | 300X150mm | Each | 6897 | 8457 | 9332 |
| | 300X200mm | Each | 7436 | 9113 | 10061 |
| | 300X250mm | Each | 7874 | 9623 | 10352 |
| | 300X300mm | Each | 8457 | 10425 | 11591 |
| | 350X200mm | Each | 9843 | 12030 | 13925 |
| | 350X250mm | Each | 10280 | 12539 | 14581 |
| | 350X300mm | Each | 10936 | 13341 | 15528 |
| | 350X350mm | Each | 11519 | 14144 | 16404 |
| (vii) | Cast Iron Plain ended Crosses | | Class 15 | Class 20 | Class 25 |
| | 80X80mm | Each | 890 | 1006 | 1166 |
| | 100X100mm | Each | 1261 | 1568 | 1808 |
| | 125X125mm | Each | 1794 | 2201 | 2537 |
| | 150X150mm | Each | 2631 | 3222 | 3682 |
| | 200X200mm | Each | 4717 | 5789 | 6635 |
| | 250X250mm | Each | 6991 | 8603 | 9623 |
| | 300X300mm | Each | 10425 | 12831 | 14362 |
| | 350X350mm | Each | 14144 | 17278 | 20121 |
| (viii) | Cast Iron Plain ended Reducers | | Class 15 | Class 20 | Class 25 |
| | 100X80mm | Each | 612 | 729 | 831 |
| | 125X80mm | Each | 722 | 860 | 984 |
| | 125X100mm | Each | 802 | 984 | 1130 |
| | 150X80mm | Each | 883 | 1057 | 1210 |
| | 150X100mm | Each | 962 | 1189 | 1364 |

| Item No. | Items | Unit | Rate in Rupees | | |
|----------|--|------|-----------------|-----------------|-----------------|
| | | | | | |
| | 150X125mm | Each | 1072 | 1313 | 1516 |
| | 200X100mm | Each | 1327 | 1640 | 1911 |
| | 200X125mm | Each | 1429 | 1764 | 2063 |
| | 200X150mm | Each | 1596 | 1969 | 2297 |
| | 250X125mm | Each | 1735 | 2173 | 2500 |
| | 250X150mm | Each | 1902 | 2362 | 2734 |
| | 250X200mm | Each | 2260 | 2814 | 3281 |
| | 300X150mm | Each | 2369 | 2960 | 3463 |
| | 300X200mm | Each | 2734 | 3412 | 4017 |
| | 300X250mm | Each | 3026 | 3645 | 4432 |
| | 350X200mm | Each | 4294 | 5271 | 6088 |
| | 350X250mm | Each | 4753 | 5847 | 6722 |
| | 350X300mm | Each | 5388 | 6635 | 7655 |
| (ix) | Cast Iron Adopter (Flange Spigot) | | Class 15 | Class 20 | Class 25 |
| | (T.P.) | | | | |
| | 80mm | Each | 540 | 576 | 619 |
| | 100mm | Each | 663 | 743 | 802 |
| | 125mm | Each | 853 | 948 | 1072 |
| | 150mm | Each | 1115 | 1247 | 1364 |
| | 200 mm | Each | 1655 | 1881 | 2093 |
| | 250 mm | Each | 2683 | 3084 | 3339 |
| | 300mm | Each | 3485 | 4032 | 4425 |
| | 350mm | Each | 4338 | 5016 | 5650 |
| (x) | Cast Iron Blank end cap | | Class 15 | Class 20 | Class 25 |
| | (Dead end cap) | | | | |
| | 80mm | Each | 248 | 269 | 320 |
| | 100mm | Each | 357 | 430 | 518 |
| | 125mm | Each | 496 | 591 | 722 |
| | 150mm | Each | 743 | 883 | 1065 |
| | 200mm | Each | 1356 | 1633 | 1983 |
| | 250mm | Each | 1925 | 2311 | 2756 |
| | 300mm | Each | 2850 | 3419 | 4112 |
| | 350mm | Each | 3740 | 4476 | 5292 |
| 5.9 | Labour for laying in position including testing following cast iron plain ended standard specials confirming to IS/5531/1988 (Reaffirmed 2002). | | | | |
| (i) | Cast Iron Plain ended 90° Bend | | Class 15 | Class 20 | Class 25 |
| | 80mm | Each | 16 | 18 | 21 |
| | 100mm | Each | 22 | 27 | 32 |
| | 125mm | Each | 32 | 39 | 44 |
| | 150mm | Each | 45 | 55 | 62 |
| | 200mm | Each | 78 | 96 | 108 |
| | 250mm | Each | 114 | 139 | 155 |

| Item No. | Items | Unit | Rate in Rupees | | |
|----------|---------------------------------|------|-----------------|-----------------|-----------------|
| | | | | | |
| | 300mm | Each | 167 | 204 | 226 |
| | 350 mm | Each | 224 | 274 | 318 |
| (ii) | Cast Iron Plain ended 45° Bend | | Class 15 | Class 20 | Class 25 |
| | 80mm | Each | 16 | 18 | 21 |
| | 100mm | Each | 22 | 27 | 31 |
| | 125mm | Each | 29 | 37 | 42 |
| | 150mm | Each | 42 | 51 | 58 |
| | 200mm | Each | 69 | 85 | 98 |
| | 250mm | Each | 98 | 121 | 135 |
| | 300mm | Each | 139 | 172 | 195 |
| | 350mm | Each | 181 | 224 | 262 |
| (iii) | Cast Iron Plain ended 22½° Bend | | Class 15 | Class 20 | Class 25 |
| | 80mm | Each | 12 | 14 | 16 |
| | 100mm | Each | 16 | 20 | 24 |
| | 125mm | Each | 21 | 27 | 32 |
| | 150mm | Each | 31 | 38 | 45 |
| | 200mm | Each | 51 | 64 | 76 |
| | 250mm | Each | 70 | 87 | 103 |
| | 300mm | Each | 99 | 125 | 147 |
| | 350mm | Each | 126 | 159 | 192 |
| (iv) | Cast Iron Plain ended 1¼° Bend | | Class 15 | Class 20 | Class 25 |
| | 80mm | Each | 10 | 11 | 13 |
| | 100mm | Each | 13 | 17 | 20 |
| | 125mm | Each | 17 | 22 | 27 |
| | 150mm | Each | 25 | 32 | 39 |
| | 200mm | Each | 42 | 53 | 66 |
| | 250mm | Each | 56 | 71 | 86 |
| | 300mm | Each | 79 | 102 | 124 |
| | 350mm | Each | 99 | 126 | 156 |
| (v) | Cast Iron Plain ended Tees | | | | |
| | Body & Branch | | Class 15 | Class 20 | Class 25 |
| | 80x80mm | Each | 20 | 23 | 27 |
| | 100x80mm | Each | 26 | 31 | 35 |
| | 100x100mm | Each | 29 | 37 | 42 |
| | 125X80mm | Each | 35 | 41 | 46 |
| | 125X100mm | Each | 38 | 48 | 54 |
| | 125X125mm | Each | 43 | 52 | 59 |
| | 150x80mm | Each | 52 | 62 | 70 |
| | 150x100mm | Each | 54 | 66 | 74 |
| | 150X125mm | Each | 57 | 70 | 79 |
| | 150x150mm | Each | 62 | 76 | 86 |
| | 200X80 mm | Each | 88 | 108 | 121 |
| | 200X100 mm | Each | 90 | 112 | 125 |
| | 200X125mm | Each | 95 | 115 | 130 |

| Item No. | Items | Unit | Rate in Rupees | | |
|-----------|--------------------------------|-------------------------------|-----------------|-----------------|-----------------|
| | | | | | |
| | 200X150 mm | Each | 101 | 122 | 137 |
| | 200X200 mm | Each | 111 | 136 | 156 |
| | 250X80 mm | Each | 130 | 138 | 175 |
| | 250X100 mm | Each | 133 | 163 | 180 |
| | 250X125mm | Each | 137 | 168 | 185 |
| | 250X150 mm | Each | 142 | 174 | 192 |
| | 250X200 mm | Each | 155 | 189 | 210 |
| | 250X250 mm | Each | 166 | 204 | 226 |
| (vi) | Cast Iron Plain ended Tees | | | | |
| | Body & Branch | | Class 15 | Class 20 | Class 25 |
| | 300X80mm | Each | 192 | 235 | 258 |
| | 300X100mm | Each | 195 | 239 | 262 |
| | 300X125mm | Each | 198 | 243 | 268 |
| | 300X150mm | Each | 202 | 247 | 274 |
| | 300X200mm | Each | 218 | 266 | 295 |
| | 300X250mm | Each | 231 | 282 | 303 |
| | 300X300mm | Each | 247 | 305 | 340 |
| | 350X200mm | Each | 288 | 352 | 408 |
| | 350X250mm | Each | 301 | 367 | 427 |
| | 350X300mm | Each | 320 | 390 | 455 |
| | 350X350mm | Each | 338 | 414 | 480 |
| | (vii) | Cast Iron Plain ended Crosses | | Class 15 | Class 20 |
| 80X80mm | | Each | 26 | 29 | 35 |
| 100X100mm | | Each | 37 | 46 | 53 |
| 125X125mm | | Each | 53 | 64 | 74 |
| 150X150mm | | Each | 77 | 95 | 108 |
| 200X200mm | | Each | 138 | 170 | 194 |
| 250X250mm | | Each | 204 | 252 | 282 |
| 300X300mm | | Each | 305 | 375 | 420 |
| 350X350mm | | Each | 414 | 505 | 589 |
| (viii) | Cast Iron Plain ended Reducers | | Class 15 | Class 20 | Class 25 |
| | 100X80mm | Each | 18 | 21 | 24 |
| | 125X80mm | Each | 21 | 25 | 28 |
| | 125X100mm | Each | 23 | 28 | 34 |
| | 150X80mm | Each | 25 | 31 | 36 |
| | 150X100mm | Each | 28 | 35 | 40 |
| | 150X125mm | Each | 32 | 39 | 45 |
| | 200X100mm | Each | 39 | 48 | 56 |
| | 200X125mm | Each | 42 | 52 | 60 |
| | 200X150mm | Each | 47 | 58 | 67 |
| | 250X125mm | Each | 51 | 64 | 73 |
| | 250X150mm | Each | 56 | 69 | 80 |
| | 250X200mm | Each | 66 | 82 | 96 |
| | 300X150mm | Each | 69 | 86 | 102 |

| Item No. | Items | Unit | Rate in Rupees | | |
|----------|---|------|-----------------|-----------------|-----------------|
| | | | | | |
| | 300X200mm | Each | 80 | 100 | 118 |
| | 300X250mm | Each | 88 | 107 | 130 |
| | 350X200mm | Each | 126 | 155 | 178 |
| | 350X250mm | Each | 139 | 171 | 197 |
| | 350X300mm | Each | 158 | 197 | 224 |
| (ix) | Cast Iron Adopter (Flange Spigot) (T.P.) | | Class 15 | Class 20 | Class 25 |
| | 80mm | Each | 16 | 17 | 18 |
| | 100mm | Each | 19 | 21 | 23 |
| | 125mm | Each | 25 | 27 | 32 |
| | 150mm | Each | 33 | 37 | 40 |
| | 200mm | Each | 49 | 55 | 61 |
| | 250 mm | Each | 78 | 90 | 98 |
| | 300mm | Each | 102 | 118 | 129 |
| | 350mm | Each | 127 | 146 | 166 |
| (x) | Cast Iron Blank end cap(Dead end cap) | | Class 15 | Class 20 | Class 25 |
| | 80mm | Each | 7 | 8 | 9 |
| | 100mm | Each | 10 | 12 | 15 |
| | 125mm | Each | 14 | 17 | 21 |
| | 150mm | Each | 21 | 25 | 32 |
| | 200mm | Each | 40 | 48 | 58 |
| | 250mm | Each | 5 | 68 | 80 |
| | 300mm | Each | 83 | 100 | 120 |
| | 350mm | Each | 110 | 131 | 155 |
| 5.10 | Labour for laying in position Cast Iron Plain Ended Specials all sizes of any class which does not appear in this U.S.O.R. | | | | |
| | 80mm to 350mm dia | Qntl | 214 | 214 | 214 |

CHAPTER – VI

GALVANISED IRON PIPES, GUN METAL / BRASS VALVES AND FITTINGS

Chapter – VI

GALVANISED IRON PIPES, SPECIALS, GUN METAL/ BRASS VALVES AND FITTINGS

NOTES:

1. The G.I. pipes shall be confirming to IS - 1239:2004 (Pt -I), 1239:1992 (Pt-II)
2. The hot dip Zinc coating on M.S. tubes shall be confirming to IS - 4736:1986
3. The Copper alloy Gate valves, Globe wheel valves, Check valves shall be confirming to IS - 778: 1984 (Reaffirmed 2005)
4. The ferrules for water service related IS - 8794:1988 and IS - 2692-1989
5. All measurement shall be of the finishedwork.
6. Work shall be executed in accordance with the Indian Standards Specifications and special notes if any, covered in the agreement of thework.
7. **This USOR contains the rates of all the items without GST. No claims against GST shall be entertained at any level. GST shall be paid by the Agency/ Contractor directly to the concerning department. Howerer, All the estimates prepared on this USOR will include GST, as an extra amount as per prevailing rates on the sum of the estimate to arrive at the gross amount.**

GALVANISED IRON PIPES, SPECIALS, GUN METAL /BRASS VALVES AND FITTINGS

| Item No. | ITEMS | Unit | Rate in Rupees | |
|----------|--|--------|----------------|--------------|
| | | | | |
| 6.1 | Providing laying and jointing of following galvanized Iron (MS) Pipes with specials (such as bends, elbows, tees etc) class light, medium & heavy including testing of joints, cost of pipes, specials and jointing materials all complete. Pipes and sockets conforming to IS:1239/2011 Part-II. | | | |
| | | | Medium | Heavy |
| | 15mm dia | R Mtr. | 108 | 127 |
| | 20mm dia | R Mtr. | 136 | 162 |
| | 25mm dia | R Mtr. | 207 | 249 |
| | 32mm dia | R Mtr. | 254 | 308 |
| | 40mm dia | R Mtr. | 301 | 366 |

| Item No. | ITEMS | Unit | Rate in Rupees | |
|----------|--|--------|----------------|----------------|
| | 50mm dia | R Mtr. | 409 | 498 |
| | 65mm dia | R Mtr. | 540 | 658 |
| | 80mm dia | R Mtr. | 676 | 796 |
| | 100mm dia | R Mtr. | 998 | 1176 |
| | 125mm dia | R Mtr. | 1305 | 1462 |
| | 150mm dia | R Mtr. | 1457 | 1634 |
| 6.2 | Labour for laying and jointing of following galvanized Iron (MS) pipes with specials (such as bends, elbows, tees etc) class light, medium & heavy including testing of joints and cost of jointing materials but excluding cost of pipes & specials. | | | |
| | | | Medium | Heavy |
| | 15mm dia | R Mtr. | 11 | 12 |
| | 20mm dia | R Mtr. | 12 | 13 |
| | 25mm dia | R Mtr. | 17 | 19 |
| | 32mm dia | R Mtr. | 18 | 20 |
| | 40mm dia | R Mtr. | 24 | 26 |
| | 50mm dia | R Mtr. | 26 | 29 |
| | 65mm dia | R Mtr. | 44 | 48 |
| | 80mm dia | R Mtr. | 47 | 52 |
| | 100mm dia | R Mtr. | 69 | 76 |
| | 125mm dia | R Mtr. | 89 | 98 |
| | 150mm dia | R Mtr. | 107 | 117 |
| 6.3 | Providing and fixing following gate (full way) valves tested to 300lbs/Sq inch or 21.00 kg/sq.cm. confirming to IS 778/1984 (Reaffirmed 2005) Class-I | | | |
| | | | Screwed | Flanged |
| | 15mm dia | Each | 423 | 550 |
| | 20mm dia | Each | 546 | 710 |
| | 25mm dia | Each | 900 | 1170 |
| | 32mm dia | Each | 1309 | 1701 |
| | 40mm dia | Each | 1681 | 2185 |
| | 50mm dia | Each | 2525 | 3282 |
| | 65mm dia | Each | 4643 | 6036 |
| | 80mm dia | Each | 6489 | 8436 |
| | 100mm dia | Each | 12269 | 15949 |
| 6.4 | Providing and fixing following gate (full way) valves tested to 300lbs/Sq inch or 21.00 kg/sq.cm. | | | |

| Item No. | ITEMS | Unit | Rate in Rupees | |
|----------|--|------|----------------|----------------|
| | confirming to IS 778/1984 (Reaffirmed 2005) Class-II | | | |
| | | | Screwed | Flanged |
| | 15mm dia | Each | 528 | 685 |
| | 20mm dia | Each | 672 | 874 |
| | 25mm dia | Each | 1117 | 1452 |
| | 32mm dia | Each | 1633 | 2123 |
| | 40mm dia | Each | 1996 | 2595 |
| | 50mm dia | Each | 3165 | 4115 |
| | 65mm dia | Each | 5773 | 7505 |
| | 80mm dia | Each | 7958 | 10346 |
| | 100mm dia | Each | 14707 | 19119 |
| 6.5 | Providing and fixing following class-I Globe wheel valves, confirming to IS 778/1984 (Reaffirmed 2005), tested to 21.09 kg/sq.cmt. | | | |
| | | | Screwed | Flanged |
| | 15mm dia | Each | 384 | 499 |
| | 20mm dia | Each | 558 | 726 |
| | 25mm dia | Each | 865 | 1125 |
| | 32mm dia | Each | 1405 | 1827 |
| | 40mm dia | Each | 1923 | 2499 |
| | 50mm dia | Each | 2637 | 3428 |
| | 65mm dia | Each | 5093 | 6620 |
| | 80mm dia | Each | 6762 | 8790 |
| | 100mm dia | Each | 11546 | 15010 |
| 6.6 | Providing and fixing following class-II Globe wheel valves, confirming to IS 778/1984 (Reaffirmed 2005), tested to 21.09 kg/sq.cmt. | | | |
| | | | Screwed | Flanged |
| | 15mm dia | Each | 475 | 617 |
| | 20mm dia | Each | 673 | 875 |
| | 25mm dia | Each | 1071 | 1392 |
| | 32mm dia | Each | 1751 | 2276 |
| | 40mm dia | Each | 2389 | 3106 |
| | 50mm dia | Each | 3339 | 4342 |
| | 65mm dia | Each | 5922 | 7698 |
| | 80mm dia | Each | 7694 | 10002 |
| | 100mm dia | Each | 13830 | 17980 |

| Item No. | ITEMS | Unit | Rate in Rupees | | |
|----------|---|------|----------------|----------------|----------------|
| 6.7 | Providing and fixing following check (non-return) valves Class-I, confirming to IS: 778/1984 (Reaffirmed 2005) female ends, tested to 21.09 kg/sq.cmt. | | | | |
| | | | | Screwed | Flanged |
| | 15mm dia | Each | | 384 | 499 |
| | 20mm dia | Each | | 558 | 726 |
| | 25mm dia | Each | | 865 | 1125 |
| | 32mm dia | Each | | 1405 | 1827 |
| | 40mm dia | Each | | 1923 | 2499 |
| | 50mm dia | Each | | 2637 | 3428 |
| | 65mm dia | Each | | 5093 | 6620 |
| | 80mm dia | Each | | 6762 | 8790 |
| | 100mm dia | Each | | 11546 | 15010 |
| 6.8 | Providing and fixing following check (non-return) valves Class-II, confirming to IS:778/1984 (Reaffirmed 2005) female ends, tested to 21.09 kg/sq.cmt. | | | | |
| | | | | Screwed | Flanged |
| | 15mm dia | Each | | 461 | 598 |
| | 20mm dia | Each | | 670 | 870 |
| | 25mm dia | Each | | 1038 | 1349 |
| | 32mm dia | Each | | 1686 | 2192 |
| | 40mm dia | Each | | 2306 | 2999 |
| | 50mm dia | Each | | 3164 | 4113 |
| | 65mm dia | Each | | 6112 | 7945 |
| | 80mm dia | Each | | 8114 | 10549 |
| | 100mm dia | Each | | 13855 | 18011 |
| 6.9 | Providing and fixing following GM or brass ferrules confirming to IS: 2692/1989 (Reaffirmed 2005), tested to 21.09 kg/sq.cm. i/c boring and tapping themain. | | | | |
| | | | | Screwed | |
| | 15mm dia | Each | | 503 | |
| | 20mm dia | Each | | 724 | |
| | 25mm dia | Each | | 1900 | |
| 6.10 | Labour for laying, fixing including testing and carriage of Screwed or flanged Gate valves (full way) Class-I | | | | |

| Item No. | ITEMS | Unit | Rate in Rupees | |
|----------|---|------|----------------|----------------|
| | | | Screwed | Flanged |
| | | | | |
| | 15mm dia | Each | 15 | 19 |
| | 20mm dia | Each | 19 | 25 |
| | 25mm dia | Each | 33 | 42 |
| | 32mm dia | Each | 47 | 61 |
| | 40mm dia | Each | 60 | 78 |
| | 50mm dia | Each | 90 | 117 |
| | 65mm dia | Each | 166 | 216 |
| | 80mm dia | Each | 232 | 302 |
| | 100mm dia | Each | 438 | 570 |
| 6.11 | Labour for laying, fixing and including testing carriage of Screwed or flanged Gate valves (full way) Class-II | | | |
| | | | Screwed | Flanged |
| | 15mm dia | Each | 19 | 24 |
| | 20mm dia | Each | 24 | 32 |
| | 25mm dia | Each | 40 | 52 |
| | 32mm dia | Each | 58 | 76 |
| | 40mm dia | Each | 71 | 93 |
| | 50mm dia | Each | 113 | 147 |
| | 65mm dia | Each | 206 | 268 |
| | 80mm dia | Each | 285 | 370 |
| | 100mm dia | Each | 526 | 683 |
| 6.12 | Labour for laying, fixing and including testing carriage of Screwed or flanged globe wheel valves Class-I | | | |
| | | | Screwed | Flanged |
| | 15mm dia | Each | 14 | 18 |
| | 20mm dia | Each | 20 | 26 |
| | 25mm dia | Each | 31 | 41 |
| | 32mm dia | Each | 50 | 65 |
| | 40mm dia | Each | 69 | 89 |
| | 50mm dia | Each | 95 | 123 |
| | 65mm dia | Each | 182 | 237 |
| | 80mm dia | Each | 242 | 314 |
| | 100mm dia | Each | 413 | 537 |
| 6.13 | Labour for laying, fixing and including testing carriage of Screwed or flanged globe wheel valves Class-II | | | |
| | | | Screwed | Flanged |
| | 15mm dia | Each | 17 | 22 |

| Item No. | ITEMS | Unit | Rate in Rupees | |
|-----------------|--|-------------|-----------------------|----------------|
| | 20mm dia | Each | 24 | 32 |
| | 25mm dia | Each | 39 | 50 |
| | 32mm dia | Each | 63 | 81 |
| | 40mm dia | Each | 85 | 111 |
| | 50mm dia | Each | 119 | 156 |
| | 65mm dia | Each | 211 | 276 |
| | 80mm dia | Each | 276 | 358 |
| | 100mm dia | Each | 494 | 643 |
| 6.14 | Labour for laying, fixing and including testing carriage of Screwed or flanged check (non-return) valves Class-I | | | |
| | 15mm dia | Each | 14 | 18 |
| | 20mm dia | Each | 20 | 26 |
| | 25mm dia | Each | 31 | 41 |
| | 32mm dia | Each | 50 | 65 |
| | 40mm dia | Each | 69 | 89 |
| | 50mm dia | Each | 95 | 123 |
| | 65mm dia | Each | 182 | 237 |
| | 80mm dia | Each | 242 | 314 |
| | 100mm dia | Each | 413 | 537 |
| 6.15 | Labour for laying, fixing and including testing carriage of Screwed or flanged check (non-return) valves Class-II | | | |
| | | | Screwed | Flanged |
| | 15mm dia | Each | 16 | 21 |
| | 20mm dia | Each | 24 | 32 |
| | 25mm dia | Each | 38 | 48 |
| | 32mm dia | Each | 60 | 78 |
| | 40mm dia | Each | 82 | 107 |
| | 50mm dia | Each | 113 | 147 |
| | 65mm dia | Each | 219 | 284 |
| | 80mm dia | Each | 290 | 377 |
| | 100mm dia | Each | 495 | 644 |
| 6.16 | Labour for laying, fixing and including testing carriage of following GM or brass ferrules | | | |
| | | | Screwed | |
| | 15mm dia | Each | 134 | |
| | 20mm dia | Each | 194 | |
| | 25mm dia | Each | 508 | |

| Item No. | ITEMS | Unit | Rate in Rupees | | | |
|-----------|--|----------|------------------------|------------------------|-------------------------|-----|
| 6.17 | Providing & fixing including testing watertaps | | | | | |
| | | | Stainless Steel | CI self closing | Brass Heavy Duty | |
| | | 15mm dia | Each | 198 | 254 | 370 |
| | 20mm dia | Each | 254 | 315 | 498 | |
| 6.18 | Labour for fixing including testing and carriage of water taps | | | | | |
| | | | Stainless Steel | CI self closing | Brass Heavy Duty | |
| | | 15mm dia | Each | 8 | 10 | 13 |
| | 20mm dia | Each | 10 | 12 | 18 | |
| 6.19 | Providing and fixing Screwed Ball valves tested to 21.09 kg/cm confirming to IS: 778/1984 | | | | | |
| | | 15mm dia | Each | | 413 | |
| | | 20mm dia | Each | | 568 | |
| | | 25mm dia | Each | | 885 | |
| | | 32mm dia | Each | | 1510 | |
| | | 40mm dia | Each | | 2143 | |
| | | 50mm dia | Each | | 3156 | |
| | | 65mm dia | Each | | 6684 | |
| | | 80mm dia | Each | | 11490 | |
| 100mm dia | Each | | 17854 | | | |
| 6.20 | Labour only for fixing and carriage of Ball valves tested to 21kg/cm confirming to IS: 778/1984 | | | | | |
| | | 15mm dia | Each | | 15 | |
| | | 20mm dia | Each | | 20 | |
| | | 25mm dia | Each | | 32 | |
| | | 32mm dia | Each | | 54 | |
| | | 40mm dia | Each | | 76 | |
| | | 50mm dia | Each | | 113 | |
| | | 65mm dia | Each | | 239 | |
| | | 80mm dia | Each | | 411 | |
| 100mm dia | Each | | 639 | | | |
| 6.21 | Providing and fixing G. I. Union in G.I. Pipe line i/c cutting threading testing etc. complete (New work) confirming to IS 1879 | | | | | |
| | | 15mm dia | Each | | 109 | |
| | | 20mm dia | Each | | 187 | |
| | | 25mm dia | Each | | 242 | |
| | | 32mm dia | Each | | 318 | |

| Item No. | ITEMS | Unit | Rate in Rupees | | |
|----------|---|------|----------------|------|--|
| | 40mm dia | Each | | 432 | |
| | 50mm dia | Each | | 559 | |
| | 65mm dia | Each | | 891 | |
| | 80mm dia | Each | | 1354 | |
| | 100mm dia | Each | | 2110 | |
| 6.22 | Labour for fixing G. I. Union in G.I. Pipe line i/c cutting threading, testing and carriage of etc. complete (New work) | | | | |
| | 15mm dia | Each | | 13 | |
| | 20mm dia | Each | | 22 | |
| | 25mm dia | Each | | 29 | |
| | 32mm dia | Each | | 39 | |
| | 40mm dia | Each | | 53 | |
| | 50mm dia | Each | | 68 | |
| | 65mm dia | Each | | 109 | |
| | 80mm dia | Each | | 165 | |
| | 100mm dia | Each | | 256 | |
| 6.23 | Providing and fixing G. I. Union in G.I. Pipe line i/c cutting threading testing etc. complete (Old work) confirming to IS1879 | | | | |
| | 15mm dia | Each | | 132 | |
| | 20mm dia | Each | | 227 | |
| | 25mm dia | Each | | 294 | |
| | 32mm dia | Each | | 385 | |
| | 40mm dia | Each | | 524 | |
| | 50mm dia | Each | | 677 | |
| | 65mm dia | Each | | 1080 | |
| | 80mm dia | Each | | 1641 | |
| | 100mm dia | Each | | 2557 | |
| 6.24 | Labour for fixing G. I. Union in G.I. Pipe line i/c cutting threading, testing and carriage etc. complete (Old work) | | | | |
| | 15mm dia | Each | | 36 | |
| | 20mm dia | Each | | 61 | |
| | 25mm dia | Each | | 78 | |
| | 32mm dia | Each | | 103 | |
| | 40mm dia | Each | | 140 | |
| | 50mm dia | Each | | 181 | |
| | 65mm dia | Each | | 289 | |
| | 80mm dia | Each | | 439 | |
| | 100mm dia | Each | | 684 | |

| Item No. | ITEMS | Unit | Rate in Rupees | | |
|-----------|---|------|----------------|-----|--|
| 6.25 | Providing and fixing G. I. socket in G.I. Pipe line i/c cutting threading testing etc. complete (Old work) confirming to IS 1879 | | | | |
| | 15mm dia | Each | | 22 | |
| | 20mm dia | Each | | 34 | |
| | 25mm dia | Each | | 46 | |
| | 32mm dia | Each | | 68 | |
| | 40mm dia | Each | | 83 | |
| | 50mm dia | Each | | 140 | |
| | 65mm dia | Each | | 183 | |
| | 80mm dia | Each | | 272 | |
| | 100mm dia | Each | | 453 | |
| | 125mm dia | Each | | 613 | |
| 150mm dia | Each | | 716 | | |
| 6.26 | Labour only for fixing G.I. socket in G.I. Pipe line i/c cutting threading, testing and carriage of etc. complete (Old work). | | | | |
| | 15mm dia | Each | | 6 | |
| | 20mm dia | Each | | 9 | |
| | 25mm dia | Each | | 12 | |
| | 32mm dia | Each | | 18 | |
| | 40mm dia | Each | | 22 | |
| | 50mm dia | Each | | 38 | |
| | 65mm dia | Each | | 49 | |
| | 80mm dia | Each | | 73 | |
| | 100mm dia | Each | | 121 | |
| | 125mm dia | Each | | 164 | |
| 150mm dia | Each | | 191 | | |
| 6.27 | Providing and fixing G. I. Bend 90 degree in G.I. Pipe line i/c cutting threading testing etc. complete (Old work) confirming to IS 1879 | | | | |
| | 15mm dia | Each | | 46 | |
| | 20mm dia | Each | | 66 | |
| | 25mm dia | Each | | 113 | |
| | 32mm dia | Each | | 192 | |
| | 40mm dia | Each | | 229 | |
| | 50mm dia | Each | | 351 | |
| | 65mm dia | Each | | 435 | |
| 80mm dia | Each | | 513 | | |

| Item No. | ITEMS | Unit | Rate in Rupees | | |
|----------|--|------|----------------|------|--|
| | 100mm dia | Each | | 1477 | |
| | 125mm dia | Each | | 1680 | |
| | 150mm dia | Each | | 2045 | |
| 6.28 | Labour only for fixing G. I. Bend 90 degree in G.I. Pipe line i/c cutting threading, testing and carriage etc. complete (Oldwork) | | | . | |
| | 15mm dia | Each | | 12 | |
| | 20mm dia | Each | | 17 | |
| | 25mm dia | Each | | 31 | |
| | 32mm dia | Each | | 51 | |
| | 40mm dia | Each | | 61 | |
| | 50mm dia | Each | | 94 | |
| | 65mm dia | Each | | 116 | |
| | 80mm dia | Each | | 137 | |
| | 100mm dia | Each | | 396 | |
| | 125mm dia | Each | | 449 | |
| | 150mm dia | Each | | 547 | |
| 6.29 | Providing and fixing G.I. Tee in G.I. Pipe line i/c cutting threading testing etc. complete (Old work) confirming to IS: 1879 | | | | |
| | 15mm dia | Each | | 70 | |
| | 20mm dia | Each | | 115 | |
| | 25mm dia | Each | | 158 | |
| | 32mm dia | Each | | 267 | |
| | 40mm dia | Each | | 348 | |
| | 50mm dia | Each | | 570 | |
| | 65mm dia | Each | | 980 | |
| | 80mm dia | Each | | 1255 | |
| | 100mm dia | Each | | 2327 | |
| 6.30 | Labour only for fixing G. I. Tee in G.I. Pipe line i/c cutting threading, testing and carriage etc. complete (Oldwork) | | | | |
| | 15mm dia | Each | | 18 | |
| | 20mm dia | Each | | 31 | |
| | 25mm dia | Each | | 42 | |
| | 32mm dia | Each | | 71 | |
| | 40mm dia | Each | | 93 | |
| | 50mm dia | Each | | 153 | |
| | 65mm dia | Each | | 262 | |
| | 80mm dia | Each | | 336 | |
| | 100mm dia | Each | | 622 | |

| Item No. | ITEMS | Unit | Rate in Rupees | | |
|----------|---|------|----------------|------|--|
| 6.31 | Providing and fixing G. I. Elbow in G.I. Pipe line i/c cutting threading testing etc. complete (Old work) confirming to IS: 1879 | | | | |
| | 15mm dia | Each | | 49 | |
| | 20mm dia | Each | | 84 | |
| | 25mm dia | Each | | 116 | |
| | 32mm dia | Each | | 190 | |
| | 40mm dia | Each | | 239 | |
| | 50mm dia | Each | | 449 | |
| | 65mm dia | Each | | 705 | |
| | 80mm dia | Each | | 951 | |
| | 100mm dia | Each | | 1849 | |
| 6.32 | Labour only for fixing G. I. Elbow in G.I. Pipe line i/c cutting threading testing etc. complete (Oldwork) | | | | |
| | 15mm dia | Each | | 13 | |
| | 20mm dia | Each | | 22 | |
| | 25mm dia | Each | | 31 | |
| | 32mm dia | Each | | 51 | |
| | 40mm dia | Each | | 64 | |
| | 50mm dia | Each | | 120 | |
| | 65mm dia | Each | | 189 | |
| | 80mm dia | Each | | 254 | |
| | 100mm dia | Each | | 495 | |
| 6.33 | Providing and fixing G. I. Nipple of minimum length in G.I. Pipe line i/c cutting, threading, testing and carriage etc. complete (Old work) confirming to IS: 1879 | | | | |
| | 15mm dia | Each | | 31 | |
| | 20mm dia | Each | | 47 | |
| | 25mm dia | Each | | 68 | |
| | 32mm dia | Each | | 115 | |
| | 40mm dia | Each | | 141 | |
| | 50mm dia | Each | | 210 | |
| | 65mm dia | Each | | 388 | |
| | 80mm dia | Each | | 573 | |
| | 100mm dia | Each | | 1072 | |

| Item No. | ITEMS | Unit | Rate in Rupees | | |
|-----------------|---|-------------|-----------------------|-----|--|
| 6.34 | Labour only for fixing G.I. Nipple of minimum length in G.I. Pipe line i/c cutting threading testing etc. complete (Old work) | | | | |
| | 15mm dia | Each | | 8 | |
| | 20mm dia | Each | | 12 | |
| | 25mm dia | Each | | 18 | |
| | 32mm dia | Each | | 31 | |
| | 40mm dia | Each | | 38 | |
| | 50mm dia | Each | | 56 | |
| | 65mm dia | Each | | 104 | |
| | 80mm dia | Each | | 154 | |
| | 100mm dia | Each | | 287 | |
| 6.35 | Providing and fixing G. I. Barrel Nipple (reducer) in G.I. Pipe line i/c cutting threading testing etc. complete (New work) confirming to IS: 1879 | | | | |
| | 15x80mm | Each | | 25 | |
| | 15x100mm | Each | | 31 | |
| | 20x80mm | Each | | 32 | |
| | 20x100mm | Each | | 35 | |
| | 25x80mm | Each | | 43 | |
| | 25x100mm | Each | | 44 | |
| | 32x80mm | Each | | 59 | |
| | 32x100mm | Each | | 76 | |
| | 40x80mm | Each | | 82 | |
| | 40x100mm | Each | | 105 | |
| | 50x80mm | Each | | 88 | |
| | 50x100mm | Each | | 115 | |
| | 50x150mm | Each | | 124 | |
| | 65x80mm | Each | | 92 | |
| | 65x100mm | Each | | 147 | |
| | 65x150mm | Each | | 214 | |
| | 80x100mm | Each | | 170 | |
| | 80x150mm | Each | | 181 | |
| | 100x150mm | Each | | 270 | |
| | 80x125mm | Each | | 298 | |
| 100x125mm | Each | | 368 | | |
| | 125x150mm | Each | | 495 | |
| 6.36 | Labour only for fixing G. I. Barrel Nipple (reducer) G.I. Pipe line i/c cutting threading testing etc. complete (New work) | | | | |

| Item No. | ITEMS | Unit | Rate in Rupees | | |
|----------|---|------|----------------|-----|--|
| | 15x80mm | Each | | 3 | |
| | 15x100mm | Each | | 4 | |
| | 20x80mm | Each | | 4 | |
| | 20x100mm | Each | | 4 | |
| | 25x80mm | Each | | 5 | |
| | 25x100mm | Each | | 5 | |
| | 32x80mm | Each | | 7 | |
| | 32x100mm | Each | | 9 | |
| | 40x80mm | Each | | 10 | |
| | 40x100mm | Each | | 13 | |
| | 50x80mm | Each | | 11 | |
| | 50x100mm | Each | | 14 | |
| | 50x150mm | Each | | 15 | |
| | 65x80mm | Each | | 11 | |
| | 65x100mm | Each | | 18 | |
| | 65x150mm | Each | | 26 | |
| | 80x100mm | Each | | 20 | |
| | 80x150mm | Each | | 22 | |
| | 100x150mm | Each | | 33 | |
| | 80x125mm | Each | | 37 | |
| | 100x125mm | Each | | 45 | |
| | 125x150mm | Each | | 60 | |
| 6.37 | Providing and fixing G. I. Barrel Nipple (reducer) in G.I. Pipe line i/c cutting threading testing etc. complete (Old work) confirming to IS: 1879 | | | | |
| | 15x80mm | Each | | 31 | |
| | 15x100mm | Each | | 37 | |
| | 20x80mm | Each | | 38 | |
| | 20x100mm | Each | | 43 | |
| | 25x80mm | Each | | 51 | |
| | 25x100mm | Each | | 53 | |
| | 32x80mm | Each | | 72 | |
| | 32x100mm | Each | | 93 | |
| | 40x80mm | Each | | 100 | |
| | 40x100mm | Each | | 127 | |
| | 50x80mm | Each | | 107 | |
| | 50x100mm | Each | | 139 | |
| | 50x150mm | Each | | 150 | |
| | 65x80mm | Each | | 111 | |
| | 65x100mm | Each | | 179 | |
| | 65x150mm | Each | | 259 | |
| | 80x100mm | Each | | 206 | |

| Item No. | ITEMS | Unit | Rate in Rupees | | |
|----------|---|------|----------------|-----|--|
| | 80x150mm | Each | | 220 | |
| | 100x150mm | Each | | 327 | |
| | 80x125mm | Each | | 362 | |
| | 100x125mm | Each | | 446 | |
| | 125x150mm | Each | | 600 | |
| 6.38 | Labour only for fixing G. I. Barrel Nipple (reducer) G.I. Pipe line i/c cutting threading testing etc. complete (Old work) | | | | |
| | 15x80mm | Each | | 8 | |
| | 15x100mm | Each | | 10 | |
| | 20x80mm | Each | | 10 | |
| | 20x100mm | Each | | 11 | |
| | 25x80mm | Each | | 13 | |
| | 25x100mm | Each | | 14 | |
| | 32x80mm | Each | | 19 | |
| | 32x100mm | Each | | 24 | |
| | 40x80mm | Each | | 26 | |
| | 40x100mm | Each | | 35 | |
| | 50x80mm | Each | | 28 | |
| | 50x100mm | Each | | 38 | |
| | 50x150mm | Each | | 41 | |
| | 65x80mm | Each | | 29 | |
| | 65x100mm | Each | | 48 | |
| | 65x150mm | Each | | 69 | |
| | 80x100mm | Each | | 55 | |
| | 80x150mm | Each | | 59 | |
| | 100x150mm | Each | | 87 | |
| | 80x125mm | Each | | 97 | |
| | 100x125mm | Each | | 119 | |
| | 125x150mm | Each | | 161 | |
| 6.39 | Providing and fixing G. I. threaded Flange in G.I. Pipe line i/c cutting threading testing etc. complete (New work) confirming to IS: 1879 | | | | |
| | 15mm dia | Each | | 77 | |
| | 20mm dia | Each | | 81 | |
| | 25mm dia | Each | | 103 | |
| | 32mm dia | Each | | 121 | |
| | 40mm dia | Each | | 149 | |
| | 50mm dia | Each | | 192 | |
| | 65mm dia | Each | | 228 | |
| | 80mm dia | Each | | 306 | |

| Item No. | ITEMS | Unit | Rate in Rupees | | |
|-----------------|--|-------------|-----------------------|------|--|
| | 100mm dia | Each | | 407 | |
| | 125mm dia | Each | | 663 | |
| | 150mm dia | Each | | 755 | |
| | 200mm dia | Each | | 1233 | |
| 6.40 | Labour only for fixing G.I. threaded Flange in G.I. Pipe line i/c cutting threading, testing and carriage etc. complete (New work) | | | | |
| | 15mm dia | Each | | 9 | |
| | 20mm dia | Each | | 10 | |
| | 25mm dia | Each | | 12 | |
| | 32mm dia | Each | | 14 | |
| | 40mm dia | Each | | 18 | |
| | 50mm dia | Each | | 23 | |
| | 65mm dia | Each | | 27 | |
| | 80mm dia | Each | | 38 | |
| | 100mm dia | Each | | 50 | |
| | 125mm dia | Each | | 80 | |
| | 150mm dia | Each | | 92 | |
| | 200mm dia | Each | | 149 | |
| 6.41 | Providing and fixing G. I. threaded Flange in G.I. Pipe line i/c cutting threading testing etc. complete (Old work) confirming to IS 1879 | | | | |
| | 15mm dia | Each | | 94 | |
| | 20mm dia | Each | | 99 | |
| | 25mm dia | Each | | 124 | |
| | 32mm dia | Each | | 146 | |
| | 40mm dia | Each | | 181 | |
| | 50mm dia | Each | | 233 | |
| | 65mm dia | Each | | 277 | |
| | 80mm dia | Each | | 371 | |
| | 100mm dia | Each | | 492 | |
| | 125mm dia | Each | | 803 | |
| | 150mm dia | Each | | 916 | |
| | 200mm dia | Each | | 1495 | |
| 6.42 | Labour only for fixing G. I. threaded Flange in G.I. Pipe line i/c cutting threading, testing and carriage etc. complete (Old work) | | | | |
| | 15mm dia | Each | | 25 | |
| | 20mm dia | Each | | 26 | |
| | 25mm dia | Each | | 34 | |

| Item No. | ITEMS | Unit | Rate in Rupees | | |
|----------|--|------|----------------|-----|--|
| | 32mm dia | Each | | 40 | |
| | 40mm dia | Each | | 49 | |
| | 50mm dia | Each | | 62 | |
| | 65mm dia | Each | | 74 | |
| | 80mm dia | Each | | 100 | |
| | 100mm dia | Each | | 132 | |
| | 125mm dia | Each | | 215 | |
| | 150mm dia | Each | | 245 | |
| | 200mm dia | Each | | 400 | |
| 6.43 | Providing and fixing wrought steel Plug in G.I. Pipe line with outer threading testing etc.complete (New & Old work) confirming to IS: 1879 | | | | |
| | 15mm dia | Each | | 20 | |
| | 20mm dia | Each | | 27 | |
| | 25mm dia | Each | | 45 | |
| | 32mm dia | Each | | 74 | |
| | 40mm dia | Each | | 106 | |
| | 50mm dia | Each | | 163 | |
| | 65mm dia | Each | | 209 | |
| | 80mm dia | Each | | 262 | |
| | 100mm dia | Each | | 467 | |
| 6.44 | Labour only for fixing wrought steel Plug in G.I. Pipe line with outer threading, testing and carriage etc. complete. (Old Work) | | | | |
| | 15mm dia | Each | | 5 | |
| | 20mm dia | Each | | 7 | |
| | 25mm dia | Each | | 12 | |
| | 32mm dia | Each | + | 20 | |
| | 40mm dia | Each | | 28 | |
| | 50mm dia | Each | | 44 | |
| | 65mm dia | Each | | 56 | |
| | 80mm dia | Each | | 70 | |
| | 100mm dia | Each | | 125 | |
| 6.45 | Providing and fixing wrought steel Cap Plug with threading in G.I. Pipe line testing etc. complete confirming to IS:1879 (New & Old Work) | | | | |
| | 15mm dia | Each | | 40 | |
| | 20mm dia | Each | | 58 | |

| Item No. | ITEMS | Unit | Rate in Rupees | | |
|-----------------|---|-------------|-----------------------|-----|--|
| | 25mm dia | Each | | 92 | |
| | 32mm dia | Each | | 130 | |
| | 40mm dia | Each | | 171 | |
| | 50mm dia | Each | | 239 | |
| | 65mm dia | Each | | 304 | |
| | 80mm dia | Each | | 491 | |
| | 100mm dia | Each | | 843 | |
| 6.46 | Labour only for fixing wrought steel Cap Plug with threading in G.I. Pipe line, testing and carriage etc. complete (Old work) | | | | |
| | 15mm dia | Each | | 10 | |
| | 20mm dia | Each | | 15 | |
| | 25mm dia | Each | | 24 | |
| | 32mm dia | Each | | 35 | |
| | 40mm dia | Each | | 46 | |
| | 50mm dia | Each | | 64 | |
| | 65mm dia | Each | | 81 | |
| | 80mm dia | Each | | 131 | |
| | 100mm dia | Each | | 226 | |
| 6.47 | Providing and fixing G. I. Cross with outer threading in G.I. Pipe line i/c cutting threading testing etc. complete (Old work) | | | | |
| | 15mm dia | Each | | 111 | |
| | 20mm dia | Each | | 146 | |
| | 25mm dia | Each | | 218 | |
| | 32mm dia | Each | | 344 | |
| | 40mm dia | Each | | 435 | |
| | 50mm dia | Each | | 687 | |
| 6.48 | Labour only for fixing G. I. cross outer threading in G.I. Pipe line i/c cutting, threading, testing and carriage etc. complete (Old work) | | | | |
| | 15mm dia | Each | | 29 | |
| | 20mm dia | Each | | 40 | |
| | 25mm dia | Each | | 58 | |
| | 32mm dia | Each | | 92 | |
| | 40mm dia | Each | | 117 | |
| | 50mm dia | Each | | 184 | |

| Item No. | ITEMS | Unit | Rate in Rupees | | |
|-----------------|---|-------------|-----------------------|-----|--|
| 6.49 | Providing and fixing Tank Nipple with outer threading in G.I. Pipe line i/c cutting threading testing etc. complete confirming to IS: 1879 | | | | |
| | 15mm dia | Each | | 82 | |
| | 20mm dia | Each | | 114 | |
| | 25mm dia | Each | | 191 | |
| | 32mm dia | Each | | 272 | |
| | 40mm dia | Each | | 358 | |
| | 50mm dia | Each | | 567 | |
| 6.50 | Labour only for Tank Nipple with outer threading in G.I. Pipe line i/c cutting, threading, testing and carriage etc. complete | | | | |
| | 15mm dia | Each | | 10 | |
| | 20mm dia | Each | | 14 | |
| | 25mm dia | Each | | 23 | |
| | 32mm dia | Each | | 34 | |
| | 40mm dia | Each | | 44 | |
| | 50mm dia | Each | | 69 | |

CHAPTER – VII
P.V.C. PIPES, O-PVC PIPES
AND FITTINGS

Chapter – VII

P.V.C. PIPES & FITTINGS

NOTES:

1. The Unplasticized P.V.C. pipes shall be confirming to IS - 4985:2000
2. The laying and jointing of UPVC pipes shall be done as per IS - 4736:1986
3. Selection, handlings, storage and instattation of UPVC pipes IS-7634:2003 (Pt-3)
4. The injection mould PVC fitting with solvent cement joint shall be confirming to IS - 7834: 1987 (Part I toVIII)
5. All measurements shall be of the finishedwork.
6. Work shall be executed in accordance with the Indian Standards Specifications and special notes if any, covered in the agreement of thework.
7. **This USOR contains the rates of all the items without GST. No claims against GST shall be entertained at any level. GST shall be paid by the Agency/ Contractor directly to the concerning department. Howerer, All the estimates prepared on this USOR will include GST, as an extra amount as per prevailing rates on the sum of the estimate to arrive at the gross amount.**

P.V.C. PIPES & FITTINGS

| S.No. | Items | Unit | Rates in RS. | | |
|-------|--|---------|---------------------------|----------------------------|----------------------------|
| 7.1 | Providing, laying and jointing following P.V.C. pipes with solvent cement joint for 6, 8 and 10 kg/ sq. cm. pressures including testing of joints, cost of jointing materials etc. complete in all respect. | | | | |
| | | | 6Kg/Cm² | 8 Kg/Cm² | 10Kg/Cm² |
| | 90 mm dia. | R. mtr. | 159 | 230 | 261 |
| | 110 mm dia. | R. mtr. | 221 | 312 | 357 |
| | 140 mm dia. | R. mtr. | 368 | 525 | 580 |
| | 160 mm dia. | R. mtr. | 471 | 666 | 750 |
| | 180 mm dia. | R. mtr. | 613 | 885 | 970 |
| 7.2 | Labour for laying in position including testing following PVC pipes of 6, 8 and 10Kg/Sqcm. pressure. | | | | |
| | | | 6Kg/Cm² | 8 Kg/Cm² | 10Kg/Cm² |
| | 90 mm dia. | R. mtr. | 4 | 4 | 4 |
| | 110 mm dia. | R. mtr. | 5 | 5 | 5 |
| | 140 mm dia. | R. mtr. | 6 | 6 | 6 |
| | 160 mm dia. | R. mtr. | 7 | 7 | 7 |
| | 180 mm dia. | R. mtr. | 9 | 9 | 9 |

| S.No. | Items | Unit | Rates in RS. | | |
|-------|--|------------|---------------------------|----------------------------|----------------------------|
| | 200 mm dia. | R. mtr. | 12.00 | 12.00 | 12.00 |
| 7.3 | Providing, Solvent Cement Joints to PVC Pipes and fittings of 6, 8 and 10 Kg/Sq cm. Pressure including testing of joints and cost of jointing materials (i.e. socket, coupler & solvent cement) | | | | |
| | | | 6Kg/Cm² | 8 Kg/Cm² | 10Kg/Cm² |
| | 90 mm dia. | Each | 24 | 24 | 24 |
| | 110 mm dia. | Each | 27 | 27 | 27 |
| | 140 mm dia. | Each | 34 | 34 | 34 |
| | 160 mm dia. | Each | 40 | 40 | 40 |
| | 180 mm dia. | Each | 43 | 43 | 43 |
| | 200 mm dia. | Each | 59 | 59 | 59 |
| 7.4 | Labour for providing solvent cement joints to PVC pipes and fittings of 6, 8 and 10Kg /Sq cm. Pressure including testing of joints but excluding cost of jointing materials (i.e. coupler and solvent cement) | | | | |
| | | | 6Kg/Cm² | 8 Kg/Cm² | 10Kg/Cm² |
| | 90 mm dia. | Each Joint | 19 | 19 | 19 |
| | 110 mm dia. | Each Joint | 20 | 20 | 20 |
| | 140 mm dia. | Each Joint | 22 | 22 | 22 |
| | 160 mm dia. | Each Joint | 24 | 24 | 24 |
| | 180 mm dia. | Each Joint | 26 | 26 | 26 |
| | 200 mm dia. | Each Joint | 33 | 33 | 325 |
| 7.5 | Providing and laying in position including testing following PVC bends suitable for 6, 8 and 10 Kg/Sq. cm. pressure pipes. | | | | |
| | | | 6Kg/Cm² | 8 Kg/Cm² | 10Kg/Cm² |
| | 90 mm dia. | Each | 156 | 205 | 254 |
| | 110 mm dia. | Each | 252 | 342 | 405 |
| | 140 mm dia. | Each | 602 | 828 | 958 |
| | 160 mm dia. | Each | 801 | 1129 | 1344 |
| | 180 mm dia. | Each | 1210 | 1538 | 1846 |
| | 200 mm dia. | Each | 1495 | 1976 | 2387 |

| S.No. | Items | Unit | Rates in RS. | | |
|-------|--|------|---------------------------|----------------------------|----------------------------|
| 7.6 | Providing and laying in position including testing following PVC Tees, suitable for 6, 8 and 10 Kg/Sqm. Pressure pipes. | | | | |
| | | | 6Kg/Cm² | 8 Kg/Cm² | 10Kg/Cm² |
| | 90 mm dia. | Each | 93 | 114 | 129 |
| | 110 mm dia. | Each | 122 | 214 | 255 |
| | 140 mm dia. | Each | 319 | 337 | 354 |
| | 160 mm dia. | Each | 530 | 556 | 678 |
| | 180 mm dia. | Each | 656 | 800 | 1004 |
| | 200 mm dia. | Each | 885 | 1165 | 1537 |
| 7.7 | Providing and laying in position including testing following PVC flanged tail pieces suitable for 6, 8 and 10 Kg./Sq. cm. Pressure pipes. | | | | |
| | | | 6Kg/Cm² | 8 Kg/Cm² | 10Kg/Cm² |
| | 90 mm dia. | Each | 66 | 70 | 75 |
| | 110 mm dia. | Each | 130 | 139 | 148 |
| | 140 mm dia. | Each | 207 | 222 | 237 |
| | 160 mm dia. | Each | 356 | 380 | 408 |
| | 180 mm dia. | Each | 477 | 509 | 546 |
| | 200 mm dia. | Each | 631 | 675 | 725 |
| 7.8 | Providing and laying in position including testing following PVC end Cap (plugs) suitable for 6, 8 and 10 Kg/Sq cm. Pressure pipes. | | | | |
| | | | 6Kg/Cm² | 8 Kg/Cm² | 10Kg/Cm² |
| | 90 mm dia. | Each | 38 | 45 | 59 |
| | 110 mm dia. | Each | 54 | 64 | 85 |
| | 140 mm dia. | Each | 84 | 103 | 137 |
| | 160 mm dia. | Each | 139 | 170 | 230 |
| | 180 mm dia. | Each | 186 | 228 | 309 |
| | 200 mm dia. | Each | 225 | 277 | 375 |
| 7.9 | Providing and laying in position including testing PVC coupler suitable for 6, 8 and 10 Kg/Sq. cm. Pressure pipes. | | | | |
| | | | 6Kg/Cm² | 8 Kg/Cm² | 10Kg/Cm² |
| | 90 mm dia. | Each | 51 | 61 | 86 |
| | 110 mm dia. | Each | 80 | 96 | 135 |
| | 140 mm dia. | Each | 150 | 181 | 282 |
| | 160 mm dia. | Each | 264 | 320 | 362 |
| | 180 mm dia. | Each | 370 | 440 | 453 |
| | 200 mm dia | Each | 477 | 517 | 545 |

| S.No. | Items | Unit | Rates in RS. | | |
|-----------------|---|------|---------------------------|----------------------------|----------------------------|
| 7.10 | Providing and laying in position including testing of following PVC Reducers suitable for 6, 8 and 10 Kg/Sq cm. Pressure pipes. | | | | |
| | | | 6Kg/Cm2 | 8 Kg/Cm2 | 10Kg/Cm2 |
| | 110x90 mm dia. | Each | 71 | 84 | 101 |
| | 140x90 mm dia. | Each | 113 | 132 | 143 |
| | 160x90 mm dia. | Each | 143 | 170 | 247 |
| | 180x90 mm dia. | Each | 149 | 177 | 262 |
| | 140x110 mm dia. | Each | 116 | 137 | 161 |
| | 160x110 mm dia. | Each | 143 | 170 | 249 |
| | 180x110 mm dia. | Each | 201 | 240 | 269 |
| | 200x110 mm dia. | Each | 258 | 307 | 357 |
| | 160x140 mm dia. | Each | 148 | 176 | 210 |
| | 180x140 mm dia. | Each | 210 | 250 | 291 |
| | 200x140 mm dia | Each | 348 | 415 | 481 |
| | 180x160 mm dia | Each | 228 | 270 | 314 |
| | 200x160 mm dia. | Each | 366 | 437 | 507 |
| 200x180 mm dia. | Each | 378 | 451 | 524 | |
| 7.11 | Labour for laying in position including testing all types of PVC fittings such as bends, tees, plugs etc. for following PVC pipes. | | | | |
| | | | 6Kg/Cm² | 8 Kg/Cm² | 10Kg/Cm² |
| | 90 mm dia. | Each | 7 | 7 | 7 |
| | 110 mm dia. | Each | 8 | 8 | 8 |
| | 140 mm dia. | Each | 10 | 10 | 10 |
| | 160 mm dia. | Each | 12 | 12 | 12 |
| | 180 mm dia. | Each | 12 | 12 | 12 |
| | 200 mm dia. | Each | 14 | 14 | 14 |
| 7.12 | Providing and fixing PVC D-joint (Detachable joint) in PVC pipe line suitable for classes up to 10kg/sqcm Pressure pipes. i/c nut bolt, cutting of pipe, testing of joints etc complete. | | | | |
| | | | 6Kg/Cm² | 8 Kg/Cm² | 10Kg/Cm² |
| | 90 mm dia. | Each | 112 | 112 | 112 |
| | 110 mm dia. | Each | 126 | 126 | 126 |
| | 140 mm dia. | Each | 169 | 169 | 169 |
| | 160 mm dia. | Each | 196 | 196 | 196 |
| | 180mm dia. | Each | 232 | 232 | 232 |
| 200mm dia. | Each | 337 | 337 | 337 | |

| S.No. | Items | Unit | Rates in RS. | | | |
|-------|---|-------------|---------------------------|----------------------------|----------------------------|----|
| 7.13 | Labour only for fixing PVC D-joint (Detachable joint) in PVC pipe line suitable for classes up to 10kg/sq.cm Pressure pipes. i/c cutting of pipe, testing of joints etccomplete. | | 6Kg/Cm² | 8 Kg/Cm² | 10Kg/Cm² | |
| | | 90 mm dia. | Each | 18 | 18 | 18 |
| | | 110 mm dia. | Each | 20 | 20 | 20 |
| | | 140 mm dia. | Each | 26 | 26 | 26 |
| | | 160 mm dia. | Each | 32 | 32 | 32 |
| | | 180mm dia. | Each | 37 | 37 | 37 |
| | | 200mm dia. | Each | 54 | 54 | 54 |

ORINTED P.V.C (O-PVC) PIPES

NOTES:-

1. The Oriented Un-plasticized Polyvinyl Chloride O-PVC pipes for potable water supply as per IS 16647:2017 duly inspected and tested and having BIS certification mark.
2. Selection, Handling, Storage and Installation of UPVC Pipes also applicable for O-PVC pipe as per IS 7634:2003 (Part-3)
3. Pipes should be stacked on a surface flat and free from sharp objects, stones of projection in order to avoid deformation of damages. Ends of pipes should be protected from abrasion and chipping.
4. In rocky area 15 cm cushion of sand or moorum below and above the pipes should be provided as per IS 7634:2003 (Part III)
5. All measurement shall be of the finished work. The net length of pipes as laid or fixed shall be measured in running meters correct to 10 mm. Specials shall be excluded and measured and paid separately under the relevant item. The portion of the pipe inside the joints not be included in the length of pipe work. Excavation refilling masonry and concrete work wherever required shall be measured and paid for separately under relevant items of work.
6. Work shall be executed in accordance with the Indian Standards Specifications and special notes if any, covered in the agreement of the work.
7. DI fittings of relevant class and size shall be used for connecting and laying the O-PVC pipe line.
8. **This USOR contains the rates of all the items without GST. No claims against GST shall be entertained at any level. GST shall be paid by the Agency/ Contractor directly to the concerning department. Howerer, All the estimates prepared on this USOR will include GST, as an extra amount as per prevailing rates on the sum of the estimate to arrive at the gross amount.**

ORIENTED P.V.C. (O-PVC) PIPES

| Sl.No. | Item | Unit | Rate In Rs |
|--------|--|------|------------|
| 7.14 | Providing, laying and jointing followings ISI marked O-PVC (Oriented uplasticized polyvinyl chloride) ring fit type pipe having orientation class 500 (IS 16647) with integral homogeneous spigot having elastomeric seeling ring made of EPDM rubber (one per pipe) including testing of joint, cost of jointing materials etc. complete in all respect. Presure Rating as per IS Code – IS: 16647:2017, PN-16 | | |
| | 110 mm dia | RMT | 610 |
| | 160 mm dia | RMT | 1001 |
| | 200 mm dia | RMT | 1233 |
| | 250 mm dia | RMT | 1809 |
| | 315 mm dia | RMT | 2383 |
| | 400 mm dia | RMT | 3589 |
| 7.15 | Providing, laying and jointing followings ISI marked O-PVC (Oriented uplasticized polyvinyl chloride) ring fit type pipe having orientation class 500 (IS 16647) with integral homogeneous spigot having elastomeric seeling ring made of EPDM rubber (one per pipe) including testing of joint, cost of jointing materials etc. complete in all respect. Presure Rating as per IS Code – IS: 16647:2017, PN-25 | | |
| | 110 mm dia | RMT | 723 |
| | 160 mm dia | RMT | 1146 |
| | 200 mm dia | RMT | 1492 |
| | 250 mm dia | RMT | 2208 |
| | 315 mm dia | RMT | 3291 |
| | 400 mm dia | RMT | 5149 |

CHAPTER – VIII

CAST IRON VALVES

Chapter – VIII CAST IRON VALVES

NOTES:

1. The Sluice Valves (50-1000 mm size) shall be confirming to IS:14846:2000
2. The resilient seated C.I. Air relief valve shall be confirming to IS:14845: 2000
3. The Swing check type reflux valves as per IS: 5312:2004 (Part I & II)
4. The Butter fly valves shall be conforming to IS -13095:1991
5. All measurement shall be of the finishedwork.
6. Work shall be executed in accordance with the Indian Standards Specifications and special notes if any, covered in the agreement of thework.
7. **This USOR contains the rates of all the items without GST. No claims against GST shall be entertained at any level. GST shall be paid by the Agency/ Contractor directly to the concerning department. Howerer, All the estimates prepared on this USOR will include GST, as an extra amount as per prevailing rates on the sum of the estimate to arrive at the gross amount.**

CAST IRON VALVES

| S.No. | Items | Unit | Rates in Rupees | |
|-------|---|------|-----------------|---------------|
| 8.1 | Providing & fixing of following Cast iron double flanged sluice valves as per I.S.:14846-2000 fitted with cast iron cap including jointing & testing with cost of jointing material such as bolts, nuts, rubber insertions etc. all complete | | PN-1.0 | PN-1.6 |
| | 50mm dia | Each | 2473 | 2654 |
| | 65mm dia | Each | 2918 | 3137 |
| | 80mm dia | Each | 3454 | 3708 |
| | 100mm dia | Each | 4749 | 5090 |
| | 125mm dia | Each | 5773 | 6203 |
| | 150mm dia | Each | 7049 | 7559 |
| | 200mm dia | Each | 12271 | 13183 |
| | 250mm dia | Each | 18040 | 19213 |
| | 300mm dia | Each | 22580 | 24067 |

| S.No. | Items | Unit | Rates in Rupees | |
|-------|--|------|-----------------|--|
| 8.2 | Fixing of following Cast iron double flanged sluice valves fitted with cast iron cap testing with cost of jointing material such as bolts, nuts, rubber insertions etc. all complete (only valve to be supplied by deptt. free of cost. | | PN-1.0 | |
| | 50mm dia | Each | 211 | |
| | 65mm dia | Each | 219 | |
| | 80mm dia | Each | 229 | |
| | 100mm dia | Each | 358 | |
| | 125mm dia | Each | 390 | |
| | 150mm dia | Each | 520 | |
| | 200mm dia | Each | 718 | |
| | 250mm dia | Each | 1160 | |
| | 300mm dia | Each | 1312 | |
| | 350 mm dia | Each | 2164 | |
| | 400 mm dia | Each | 3322 | |
| | 450 mm dia | Each | 4019 | |
| | 500 mm dia | Each | 5074 | |
| | 600 mm dia | Each | 7351 | |
| | 700 mm dia | Each | 8747 | |
| | 750 mm dia | Each | 9406 | |
| | 800 mm dia | Each | 12380 | |
| | 900 mm dia | Each | 14009 | |
| | 1000 mm dia | Each | 17783 | |
| 8.3 | Labour for laying and fixing of following cast iron double flanged sluice valves (vide item no.1) including jointing and testing but without cost of Jointing materials. | | | |
| | 50mm dia | Each | 77 | |
| | 65mm dia | Each | 97 | |
| | 80mm dia | Each | 109 | |
| | 100mm dia | Each | 150 | |
| | 125mm dia | Each | 177 | |
| | 150mm dia | Each | 220 | |
| | 200mm dia | Each | 328 | |
| | 250mm dia | Each | 472 | |
| | 300mm dia | Each | 609 | |
| | 350mm dia | Each | 1064 | |
| | 400mm dia | Each | 1258 | |
| | 450mm dia | Each | 1504 | |
| | 500mm dia | Each | 1820 | |
| | 600mm dia | Each | 2769 | |
| | 700mm dia | Each | 3175 | |

| S.No. | Items | Unit | Rates in Rupees | |
|-------|--|------|----------------------|-----------------------|
| | 750mm dia | Each | 3297 | |
| | 800mm dia | Each | 3746 | |
| 8.4a | Providing & fixing following cast iron double flanged single door reflux (non return) valves including jointing & testing with cost of jointing material such as bolts,nuts and rubber insertion all complete as per IS :5312 (Part I) | | CLASS-PN- 1.0 | |
| | 50mm dia | Each | 1904 | |
| | 65mm dia | Each | 2386 | |
| | 80mm dia | Each | 2972 | |
| | 100mm dia | Each | 3808 | |
| | 150mm dia | Each | 6590 | |
| | 200mm dia | Each | 12793 | |
| | 250mm dia | Each | 19073 | |
| | 300mm dia | Each | 24694 | |
| | 350mm dia | Each | 42789 | |
| 8.4b | Providing & fixing following cast iron double flanged multi door reflux (non return) valves including jointing & testing with cost of jointing material such as bolts,nuts and rubber insertion all complete as per IS : 5312 (Part II) | | CLASS PN- 1.0 | CLASS PN- 1.60 |
| | 400mm dia | Each | 51266 | 60610 |
| | 450mm dia | Each | 60228 | 86661 |
| | 500mm dia | Each | 107469 | 162225 |
| | 600mm dia | Each | 147937 | 202516 |
| | 700mm dia | Each | 168653 | 255722 |
| | 750mm dia | Each | 247478 | 297522 |
| | 800mm dia | Each | 281305 | 340179 |
| 8.5 | Labour for laying and fixing of following Cast Iron Double Flanged reflux (non return) valves including jointing & testing but without cost of jointingmaterials | | | |
| | 50mm dia | Each | 61 | |
| | 65mm dia | Each | 76 | |
| | 80mm dia | Each | 87 | |
| | 100mm dia | Each | 120 | |
| | 125mm dia | Each | 138 | |
| | 150mm dia | Each | 169 | |
| | 200mm dia | Each | 209 | |
| | 250mm dia | Each | 343 | |

| S.No. | Items | Unit | Rates in Rupees | |
|--------------|---|-------------|------------------------|---------------------|
| | 300mm dia | Each | 435 | |
| | 350mm dia | Each | 668 | |
| | 400mm dia | Each | 870 | |
| | 450mm dia | Each | 980 | |
| | 500mm dia | Each | 1223 | |
| | 600mm dia | Each | 1860 | |
| | 700mm dia | Each | 2134 | |
| | 750mm dia | Each | 2216 | |
| | 800mm dia | Each | 2518 | |
| 8.6 | Providing & fixing following cast iron butterfly valves including jointing & testing with cost of jointing material such as bolts,nuts and rubber insertion all complete as per IS :13095-1991 | | CLASS PN- 1.0 | CLASS PN-1.6 |
| | 50mm dia | Each | 1560 | 1637 |
| | 65mm dia | Each | 1785 | 1875 |
| | 80mm dia | Each | 2043 | 2144 |
| | 100mm dia | Each | 2720 | 2855 |
| | 150mm dia | Each | 3464 | 3637 |
| | 200mm dia | Each | 6634 | 6965 |
| | 250mm dia | Each | 11114 | 11669 |
| | 300mm dia | Each | 15169 | 15927 |
| 8.7 | Labour for laying and fixing of following Cast Iron butterfly valves including jointing & testing but without cost of jointing materials | | | |
| | 50mm dia | Each | 61 | |
| | 65mm dia | Each | 76 | |
| | 80mm dia | Each | 87 | |
| | 100mm dia | Each | 120 | |
| | 150mm dia | Each | 138 | |
| | 200mm dia | Each | 169 | |
| | 250mm dia | Each | 209 | |
| | 300mm dia | Each | 343 | |
| 8.8 | Providing & fixing following cast iron single air valves, small orifice with screwed end as per IS: 14845-2000 including jointing & testing with cost of jointing material and rubber insertion all complete as per IS :13095-1991 | | CLASS PN- 1.0 | CLASS PN-1.6 |
| | 25mm dia | Each | 2912 | 3057 |
| | 40mm dia | Each | 3087 | 3242 |

| S.No. | Items | Unit | Rates in Rupees | |
|-------|---|------|----------------------|----------------------|
| 8.9 | Labour for laying and fixing of following Cast Iron Air valves small orifice with screwed end i/c jointing & testing but without cost of jointing material. | | | |
| | 25mm dia | Each | 25 | |
| | 40mm dia | Each | 34 | |
| 8.10 | Providing & fixing following cast iron single acting air valves, large orifice with screwed end as per IS : 14845-2000 including jointing & testing with cost of jointing material and rubber insertion all complete as per IS :13095-1991 | | CLASS PN- 1.0 | CLASS PN- 1.6 |
| | 25mm dia | Each | 2912 | 3057 |
| | 40mm dia | Each | 3087 | 3242 |
| | 50mm dia | Each | 3582 | 3761 |
| 8.11 | Labour for laying and fixing of following Cast Iron Air valves large orifice with screwed end i/c jointing & testing but without cost of jointing material. | | | |
| | 25mm dia | Each | 25 | |
| | 40mm dia | Each | 34 | |
| | 50mm dia | Each | 61 | |
| 8.12 | Providing & fixing following cast iron double acting air valves, flanged without in-built isolating valve as per IS : 14845-2000 including jointing & testing with cost of jointing material and rubber insertion all complete as per IS :13095-1991 | | CLASS PN- 1.0 | CLASS PN- 1.6 |
| | 40mm dia | Each | 3309 | 3473 |
| | 50mm dia | Each | 3918 | 4113 |
| | 65mm dia | Each | 4134 | 4341 |
| | 80mm dia | Each | 5768 | 6056 |
| | 100mm dia | Each | 9023 | 9473 |
| | 150mm dia | Each | 16688 | 17522 |
| | 200mm dia | Each | 28443 | 29865 |
| 8.13 | Labour for laying and fixing including testing following Cast Iron double acting air valves, flanged without in-built isolating valve. | | | |
| | 40mm dia | Each | 34 | |
| | 50mm dia | Each | 61 | |
| | 65mm dia | Each | 76 | |
| | 80mm dia | Each | 87 | |

| S.No. | Items | Unit | Rates in Rupees | |
|--------------|---|-------------|------------------------|----------------------|
| | 100mm dia | Each | 120 | |
| | 150mm dia | Each | 138 | |
| | 200mm dia | Each | 169 | |
| 8.14 | Providing & fixing following cast iron double acting air valves, flanged with inbuilt isolating valve as per IS : 14845-2000 including jointing & testing with cost of jointing material and rubber insertion all complete as per IS :13095-1991 | | CLASS PN- 1.0 | CLASS PN- 1.6 |
| | 40mm dia | Each | 3636 | 3818 |
| | 80mm dia | Each | 6337 | 6653 |
| | 100mm dia | Each | 9915 | 10411 |
| | 150mm dia | Each | 18343 | 19260 |
| | 200mm dia | Each | 29297 | 30761 |
| 8.15 | Labour for laying and fixing, including testing following Cast Iron double acting air valves, flanged with in-built isolating valve. | | | |
| | 40mm dia | Each | 34 | |
| | 80mm dia | Each | 61 | |
| | 100mm dia | Each | 120 | |
| | 150mm dia | Each | 138 | |
| | 200mm dia | Each | 169 | |

CHAPTER - IX

**HDPE PIPE, MDPE PIPE
&
SPECIALS**

CHAPTER -IX

HDPE PIPE, MDPE PIPE & SPECIALS

NOTES:

1. This specification covers the requirements for successfully designing, manufacturing, supplying, laying, jointing and testing at works and site of High Density Polyethylene Pipes used for water supply. Use of HDPE Pipes shall be of pressure class of minimum PN 6 or above.

2. **Applicable Codes**

The manufacturing, testing, supplying, laying, jointing and testing at work sites of HDPE pipes shall comply with IS: 4984-2016 all currently applicable statutes, regulations, standards and amendments and others as follows-

| Code no. | Title / Specification |
|----------|---|
| IS 4984 | High Density Polyethylene Pipes renamed as PE (Polyethylene Pipes) for Water Supply |
| IS 2530 | Methods of test for polyethylene molding materials and polyethylene compounds GRP Pipes, Joints and Fittings for use for Potable Water Supply |
| IS 5382 | Rubber sealing rings for gas mains, water mains and sewers. |
| IS 4905 | Methods for random sampling |
| IS 7328 | High density polyethylene materials for molding and extrusion |
| IS 7634 | Laying & Jointing of Polyethylene (PE) Pipes |
| IS 9845 | Method of analysis for the determination of specific and/or overall migration of constituents of plastics material and articles intended to come into contact with foodstuffs |
| IS 10141 | Positive list of constituents of polyethylene in contact with food stuffs, pharmaceuticals and drinking water. |
| IS 10146 | Polyethylene for its safe use in contact with foodstuff, Pharmaceuticals and drinking water. |

3. **Color**

The color of the pipe shall be black.

4. **Materials**

The material used for the manufacturer of pipes should not constitute toxicity hazard, should not support microbial growth, should not give rise to unpleasant taste or odour, cloudiness or discoloration of water. Pipe manufacturers shall obtain a certificate to this effect from the manufacturers of raw material by any internationally reputed organization as per the satisfaction of the Engineer-in-Charge.

5. Raw Material

- (a) Resin used to manufacture the HDPE pipes shall be 100% virgin PE Black pre-compounded confirming to IS: 4984, IS: 7328 and ISO: 4427-2007 (latest version). The resin proposed to be used for manufacturing of the pipes should also comply with the following norms as per ISO 9080-2003 (latest version).
- (b) The resin should also have been certified by an independent laboratory of international repute like Bodycote/Slevan/Advantica for having passed 10,000 hour long term hydrostatic strength (LTHS) test extrapolated to 50 years to show that the resin has a minimum MRS of over 10MPa. There should not be any brittle knee at 80°C before 5000 hours. Internal certificate of any resin manufacturer will not be acceptable.
- (c) Certificate from reputed organization OR Raw material supplier for having passed the full scale rapid crack propagation test as per ISO 13478. High density Polyethylene (HDPE) used for the manufacture of pipes shall conform to designation PEEWA-50-T-003 of IS 7328. HDPE conforming to designation PEEWA-50-T-003 of IS: 7328 may also be used. Melt Flow Rate (MFR) of the specific base density material shall also conform to clause of IS: 7328.
- (d) The resin shall be compounded with carbon black. The carbon black content in the material shall be within $2.5 \pm 0.5\%$ and the dispersion of carbon black shall be satisfactory when tested as per IS: 2530.

6. Anti-oxidant

The percentage of anti-oxidant used shall not be more than 0.3 percent by mass of finished resin. The anti-oxidant used shall be physiologically harm less and shall be selected from the list given in IS: 10141

7. Reworked Material

No addition of Reworked/ Recycled Material from the manufacturer's own rework material resulting from the manufacture of pipes is permissible and the vendor is required to use only 100% virgin resin compound.

8. Maximum Ovality of Pipe

The outside diameter of pipes, tolerance on the same and ovality of pipe shall be as given in table 2 of IS: 4984.

9. Detectability

HDPE Pipes shall be detectable when buried underground, by providing an insulated copper wire having minimum diameter of 1.20 mm, firmly attached along the entire length of pipe.

To avoid theft or dislocation during handling / laying or earth refilling in trench, the insulated Copper wire shall be firmly fixed on the outer surface of HDPE pipe at Pipe manufacturer's works through external adhesion or co- extrusion or any other appropriate method.

10. Length of Straight Pipe

The length of straight pipe used shall be more than 6 m or as agreed by Engineer-in-Charge in charge. Short lengths of 3 meter (minimum) up to a maximum of 10% of the total supply may be permitted.

11. Coiling

The pipes supplied in coils shall be coiled on drums of minimum diameter of

25 times the nominal diameter of the pipe ensuring that kinking of pipe is prevented. Pipe beyond 110mm dia shall be supplied in straight length not less than 6m.

12. Fittings & Specials

All HDPE fittings/ specials shall be of minimum PN 6 or above Pressure class, fabricated in accordance with IS: 8360 (Part I & III). PE Injection molded fittings shall be as per IS:8008 (Part I to IX). All fittings/specials shall be fabricated or molded at factory only. No fabrication or molding will be allowed at site, unless specifically permitted by the Engineer-in-Charge. Fittings will be welded on to the pipes or other fittings by use of Electro- fusion process. Recommended makes for PE/ Compression fittings / specials are Kimplas, Georg-Fischer, Glynwed, Trustlene, Astore, Magnum and GPS.

13. Bends

HDPE bends shall be plain square ended conforming to IS: 8360 Part I & III Specifications.

Bends shall be molded.

14. Tees

HDPE Tees shall be plain square ended conforming to IS: 8360 Part I & II Specifications.

Tees may be equal tees or reduced take off tees. Tees shall be molded.

15. Reducers

HDPE Reducers shall be plain square ended conforming to IS: 8008 Part I & VII

Specifications. Reducer must be molded.

16. Flanged HDPE Pipe Ends

HDPE Stub ends shall be square ended conforming to IS: 8008 Part I & VI Specifications. Stub ends will be welded on the pipe. Flange will be of slip on flange type as described below.

17. Slip-On Flanges

Slip-on flanges shall be metallic flanges covered by epoxy coating or plastic powder coating. Slip-on-flanges shall be conforming to standard mating relevant flange of valves, pipes etc. Nominal pressure rating of flanges will be PN10.

18. Electro Fusion Tapping Saddle, Branch Saddle & Electro Fusion fittings:

- a. All the Electro fusion fittings should be manufactured with top quality virgin pre-compounded PE 100 resin which should be compatible with the distribution mains.
- b. The products shall comply with the requirements of EN 12201-3, EN 1555-3 or ISO 8085-3.
- c. All the fittings shall be of SDR 11 rating.
- d. The fittings shall have the approval from any three Agencies like KIWA, DVGW, WRC-NSF, U.K. CIPET etc.

- e. All the products shall be manufactured by injection molding using virgin compounded PE 100 polymer having a melt flow rate between 0.2-1.4 grams/10 minutes and shall be compatible for fusing on PE 100 distribution mains manufactured according to the relevant national or international standards. The polymer used should comply with the requirements of EN 12201-1.
- f. Process voltage of all saddles must not exceed a maximum of 40 volts.

19. Compression Fitting-

Compression fitting used for House service connection should comply as per ISO 14236 with Threaded metal inserts –SS 304 with BSP Threads

Pressure Testing-

The Pressure rating of compression fittings should be as per clause 8 of ISO 14236 which shall be PN 16

Dimensions-

The Dimension of compression fittings shall be as per clause 7.1 of ISO 14236 Performed.

- Leaktightness under internal pressure.
- Leaktightness under internal Vacuum.
- Long term Pressure Test for Leaktightness for assembled joint
- MRS Value as per ISO 9080
- Resistance to Internal Pressure.

Effects on Quality of Water-

The Compression fitting for intended for conveyance of Potable water for Human consumption to be tested to comply with BS 6920 specifications in any of the laboratories like DVGW/ KIWA/ SPGN/ WRC –NSF and certificate of compliance to be produced for the following parameters:

- a. Odor & Flavor of Water.
- b. Appearance of Water.
- c. Growth of Micro Organism.
- d. Extraction of Metals.
- e. All fittings with threaded ends should be with BSP threads.

8. **This USOR contains the rates of all the items without GST. No claims against GST shall be entertained at any level. GST shall be paid by the Agency/ Contractor directly to the concerning department. Howerer, All the estimates prepared on this USOR will include GST, as an extra amount as per prevailing rates on the sum of the estimate to arrive at the gross amount.**

**HDPE PIPE (NOW RENAMED AS POLYETHYLENE PIPES)
MDPE PIPE & SPECIALS**

| S.No. | Items | Unit | Rates in Rs. | | |
|------------|--|---------|-------------------------|-------------------------|--------------------------|
| 9.1 | Providing, Laying, Jointing & field testing of HDPE pipes (High Density Polyethylene Pipes) confirming to IS 4984/14151/12786/13488 with necessary jointing material like mechanical connector of jointing pipes by heating to the ends of pipes with the help of Teflon coated electric mirror/ heater to the required temperature and then pressing the ends together against each other, to form a monolithic & leak proof joint by thermosetting process. It may be required to be done with Jack/ Hydraulic Jacks/ Butt fusion machine. (50 mm & above fusion jointed & below 50mm mechanical jointed) | | | | |
| | Pressure → | | 6Kg/ sq.cm : | 8Kg/ sq.cm : | 10 Kg/ sq.cm: |
| | 63 mm dia | R. mtr. | 116 | 142 | 176 |
| | 75 mm dia | R. mtr. | 167 | 204 | 250 |
| | 90 mm dia | R. mtr. | 236 | 287 | 359 |
| | 110 mm dia | R. mtr. | 395 | 433 | 527 |
| | 125 mm dia | R. mtr. | 459 | 555 | 679 |
| | 140 mm dia | R. mtr. | 572 | 698 | 851 |
| | 160 mm dia | R. mtr. | 766 | 915 | 1115 |
| | 180 mm dia | R. mtr. | 946 | 1148 | 1412 |
| | 200 mm dia | R. mtr. | 1170 | 1418 | 1737 |
| | 225 mm dia | R. mtr. | 1480 | 1795 | 2207 |
| | 250 mm dia | R. mtr. | 1825 | 2209 | 2713 |
| | 280 mm dia | R. mtr. | 2278 | 2777 | 3405 |
| 315 mm dia | R. mtr. | 2872 | 3518 | 4309 | |
| 9.2 | Providing and laying including testing Bend 90° confirming to specification. | | | | |
| | Pressure → | | 6Kg/ sq.cm : | 8Kg/ sq.cm : | 10Kg/ sq.cm: |
| | 63 mm dia | Each | 84 | 90 | 126 |
| | 75 mm dia | Each | 131 | 135 | 162 |
| | 90 mm dia | Each | 202 | 217 | 259 |
| | 110 mm dia | Each | 268 | 313 | 351 |
| | 125 mm dia | Each | 385 | 465 | 589 |
| | 140 mm dia | Each | 523 | 652 | 805 |
| | 160 mm dia | Each | 749 | 942 | 1171 |
| | 180 mm dia | Each | 1035 | 1310 | 1641 |
| 200 mm dia | Each | 1387 | 1762 | 2217 | |

| S.No. | Items | Unit | Rates in Rs. | | |
|------------|---|------|----------------------------------|----------------------------------|-----------------------------------|
| 9.3 | Providing and laying including testing Bend 45° confirming to IS specification. | | | | |
| | Pressure → | | 6Kg/ sq.cm : | 8Kg/ sq.cm : | 10Kg/ sq.cm: |
| | 63 mm dia | Each | 98 | 98 | 128 |
| | 75 mm dia | Each | 148 | 148 | 196 |
| | 90 mm dia | Each | 214 | 214 | 290 |
| | 110 mm dia | Each | 317 | 365 | 460 |
| | 125 mm dia | Each | 441 | 535 | 676 |
| | 140 mm dia | Each | 644 | 750 | 967 |
| | 160 mm dia | Each | 928 | 1141 | 1389 |
| | 180 mm dia | Each | 1256 | 1387 | 1904 |
| 200 mm dia | Each | 1654 | 1788 | 2524 | |
| 9.4 | Providing and laying including testing Equal Tee confirming to IS specification. | | | | |
| | Pressure → | | 6Kg/ sq.cm: PN6 | 8Kg/ sq.cm: PN8 | 10Kg/ sq.cm: PN10 |
| | 63 mm dia | Each | 104 | 115 | 127 |
| | 75 mm dia | Each | 172 | 179 | 220 |
| | 90 mm dia | Each | 305 | 310 | 375 |
| | 110 mm dia | Each | 446 | 461 | 539 |
| | 125 mm dia | Each | 493 | 617 | 730 |
| | 140 mm dia | Each | 674 | 844 | 1001 |
| | 160 mm dia | Each | 973 | 1227 | 1463 |
| | 180 mm dia | Each | 1352 | 1714 | 2058 |
| 200 mm dia | Each | 1821 | 2319 | 2792 | |
| 9.5 | Providing and laying including testing Pipe end confirming to IS specification. | | | | |
| | Pressure → | | 6Kg/ sq.cm : PN 6 | 8Kg/ sq.cm : PN 8 | 10Kg/ sq.cm: PN 10 |
| | 63 mm dia | Each | 75 | 77 | 79 |
| | 75 mm dia | Each | 97 | 105 | 105 |
| | 90 mm dia | Each | 140 | 158 | 158 |
| | 110 mm dia | Each | 178 | 210 | 210 |
| | 125 mm dia | Each | 277 | 313 | 313 |
| | 140 mm dia | Each | 348 | 396 | 396 |
| | 160 mm dia | Each | 354 | 416 | 416 |
| | 180 mm dia | Each | 547 | 625 | 625 |
| 200 mm dia | Each | 583 | 646 | 668 | |

| S.No. | Items | Unit | Rates in Rs. | | |
|------------|--|------|--------------------------------|--------------------------------|-----------------------------------|
| 9.6 | Providing and laying including testing Reducer: confirming to IS specifications. | | | | |
| | Pressure → | | 6Kg/ sq. cm PN6 | 8Kg/ sq.cm PN 8 | 10Kg/ sq. cm PN 10 |
| | 63 mm dia | Each | 93 | 94 | 97 |
| | 75 mm dia | Each | 118 | 120 | 126 |
| | 90 mm dia | Each | 127 | 133 | 140 |
| | 110 mm dia | Each | 129 | 156 | 166 |
| | 125 mm dia | Each | 135 | 181 | 185 |
| | 140 mm dia | Each | 161 | 199 | 205 |
| | 160 mm dia | Each | 209 | 260 | 290 |
| | 180 mm dia | Each | 246 | 332 | 369 |
| 200 mm dia | Each | 284 | 387 | 413 | |
| 9.7 | Providing butt fusion welded joint/joining by heating to the ends with the help of Teflon coated electric mirror/heater ends together etc. by thermosetting processes to HDPE Pipe and specials. (6 kg. 8 kg. 10 kg.) (50 mm & above fusion jointed & below 50 mm mechanical jointed) including testing | | | | |
| | 63 mm dia | Each | | 107 | |
| | 75 mm dia | Each | | 134 | |
| | 90 mm dia | Each | | 148 | |
| | 110 mm dia | Each | | 164 | |
| | 125 mm dia | Each | | 197 | |
| | 140 mm dia | Each | | 209 | |
| | 160 mm dia | Each | | 227 | |
| | 180 mm dia | Each | | 239 | |
| | 200 mm dia | Each | | 254 | |
| 9.8 | Providing and laying including testing End Cap confirming to IS specifications. | | | | |
| | Pressure → | | 6Kg/ sq.cm | 8Kg/ sq.cm | 10Kg/ sq.cm |
| | 63 mm dia | Each | 76 | 77 | 81 |
| | 75 mm dia | Each | 95 | 100 | 104 |
| | 90 mm dia | Each | 107 | 108 | 115 |
| | 110 mm dia | Each | 112 | 112 | 118 |

| S.No. | Items | Unit | Rates in Rs. | | |
|--------|---|--------|-----------------------|-----------------------|-------------------------|
| | 125 mm dia | Each | 134 | 185 | 188 |
| | 140 mm dia | Each | 193 | 220 | 226 |
| | 160 mm dia | Each | 230 | 320 | 334 |
| | 180 mm dia | Each | 330 | 385 | 402 |
| | 200 mm dia | Each | 395 | 461 | 480 |
| 9.9 | Providing and Supplying Blue MDPE pipes conforming to ISO 4427:1996 manufactured from virgin resin PE 80 Food grade compounded Raw Material having Blue Colour only with quality assurance certificate from quality agencies like WRC/CIPET (India)/ DVGW /KIWA /SPGN etc. for usage in Drinking Water System The cost shall include testing of all materials, Inspection charges, transportation up to site, transit insurance, loading, unloading, stacking etc. complete. | | | | |
| | PN 16 (SDR 9) | | 6Kg/ sq.cm | 8Kg/ sq.cm | 10 Kg/ sq.cm |
| | 20 mm dia | R. mtr | 37 | | |
| | 25 mm dia | R. mtr | 51 | | |
| | 32 mm dia | R. mtr | 84 | | |
| | 40 mm dia | R. mtr | 110 | | |
| | 50 mm dia | R. mtr | 167 | | |
| 9.10 | Providing & Supply of Electro Fusion Tapping Ferrule (Branch Tapping Saddle) female BSP Threaded with SS 304 insert fittings in accordance with BS EN 12201 : Part-3 suitable for drinking water with in black/ blue colour manufactured from compounded PE80/PE100 pipes, in pressure rating SDR 11 with minPN 12.5 rated. The cost such as testing, inspection charges, transportation up to site, transit insurance, loading, unloading, stacking etc. complete. | | | | |
| 9.10.1 | Electo Fusion Tapping Ferrule Saddle | | | | |
| 9.10.1 | 63x15mm | Each | 1016 | | |
| 9.10.2 | 63x20mm | Each | 1016 | | |
| 9.10.3 | 63x25mm | Each | 1016 | | |
| 9.10.4 | 75x15mm | Each | 1016 | | |
| 9.10.5 | 75x20mm | Each | 1016 | | |
| 9.10.6 | 75x25mm | Each | 1016 | | |

| S.No. | Items | Unit | Rates in Rs. |
|--------------|---|-------------|---------------------|
| 9.10.7 | 90x15mm | Each | 1016 |
| 9.10.8 | 90x20mm | Each | 1016 |
| 9.10.9 | 90x25mm | Each | 1016 |
| 9.10.10 | 90x32mm | Each | 1318 |
| 9.10.11 | 90X40mm | Each | 1318 |
| 9.10.12 | 90X50mm | Each | 1318 |
| 9.10.13 | 110X15mm | Each | 1016 |
| 9.10.14 | 110X20mm | Each | 1016 |
| 9.10.15 | 110X25mm | Each | 1016 |
| 9.10.16 | 110X32mm | Each | 1318 |
| 9.10.17 | 110x40mm | Each | 1318 |
| 9.10.18 | 110x50mm | Each | 1318 |
| 9.10.19 | 160x15mm | Each | 1016 |
| 9.10.20 | 160x20mm | Each | 1016 |
| 9.10.21 | 160x25mm | Each | 1016 |
| 9.10.22 | 160x32mm | Each | 1440 |
| 9.10.23 | 160x40mm | Each | 1440 |
| 9.10.24 | 160x50mm | Each | 1440 |
| 9.10.25 | 200x15mm | Each | 1434 |
| 9.10.26 | 200x20mm | Each | 1434 |
| 9.10.27 | 200x25mm | Each | 1434 |
| 9.10.28 | 200x32mm | Each | 2074 |
| 9.10.29 | 200x40mm | Each | 2074 |
| 9.10.30 | 200x50mm | Each | 2074 |
| 9.11 | Providing & Supply of Compression fitting, PN 16 rated in conformation to ISO: 14236-2000 and shall be tested as per ISO: 3459, ISO: 3501 & ISO:3503, suitable for drinking water & approved by WRAS, UKI KIWA etc., in food grade polypropylene and shall be inclusive of all cost such as testing, inspection charges, transportation up to site, transit insurance, loading, unloading, stacking etc. complete. | | |
| 9.11.1.1 | Compression Fittings Metal inserted Compression Female Threaded Adaptor with SS 304 Material | | |
| 9.11.1.1 | 20x15mm | Each | 173 |
| 9.11.1.2 | 25x20mm | Each | 224 |

| S.No. | Items | Unit | Rates in Rs. |
|--------------|--|-------------|---------------------|
| 9.11.1.3 | 32x25mm | Each | 305 |
| 9.11.1.4 | 40x32mm | Each | 519 |
| 9.11.1.5 | 50x40mm | Each | 671 |
| 9.11.1.6 | 63x50mm | Each | 915 |
| 9.11.2 | Metal inserted Compression Male Threaded Adaptor with SS 304Material | | |
| 9.11.2.1 | 20x15mm | Each | 173 |
| 9.10.2.2 | 25X20mm | Each | 224 |
| 9.11.2.3 | 32X25mm | Each | 305 |
| 9.11.2.4 | 40X32mm | Each | 519 |
| 9.11.2.5 | 50x40mm | Each | 671 |
| 9.11.2.6 | 63x50mm | Each | 915 |
| 9.11.3 | Compression 90° Elbow threaded male off take in Metal | | |
| 9.11.3.1 | 20x15mm | Each | 183 |
| 9.11.3.2 | 25X20mm | Each | 244 |
| 9.11.3.3 | 32X25mm | Each | 336 |
| 9.11.3.4 | 40X32mm | Each | 1169 |
| 9.11.3.5 | 50x40mm | Each | 1525 |
| 9.11.3.6 | 63x50mm | Each | 2237 |
| 9.11.4 | Compression 90° Elbow threaded Female off take inMetal | | |
| 9.11.4.1 | 20x15mm | Each | 183 |
| 9.11.4.2 | 25X20mm | Each | 244 |
| 9.11.4.3 | 32X25mm | Each | 336 |
| 9.11.4.4 | 40X32mm | Each | 1169 |
| 9.11.4.5 | 50x40mm | Each | 1525 |
| 9.11.4.6 | 63x50mm | Each | 2237 |
| 9.11.5 | Compression 90° Elbow | | |
| 9.11.5.1 | 20mm | Each | 112 |
| 9.11.5.2 | 25mm | Each | 153 |
| 9.11.5.3 | 32mm | Each | 198 |
| 9.11.5.4 | 40mm | Each | 397 |
| 9.11.5.5 | 50mm | Each | 563 |
| 9.11.5.6 | 63mm | Each | 764 |
| 9.12 | Providing & Supply of PVC Ball Valves in PN16 rating with one end compression using Blue color compression nut in polypropylene | | |

| S.No. | Items | Unit | Rates in Rs. |
|--------|---|------|--------------|
| | material & other end with female threads conforming to ISO: 4422-4, certified from WRAS UK/KIWA etc. suitable for food products & drinking water, female threads in accordance with ISO:7/BS/:21/IS: 554 and shall be inclusive of all cost such as testing, inspection charges, transportation up to site, transit insurance, loading, unloading, stacking etc.complete. | | |
| | PVC Ball Valve with Compression & Female Threads. | | |
| 9.12.1 | 20x15mm | Each | 178 |
| 9.12.2 | 25X20mm | Each | 231 |
| 9.12.3 | 32X25mm | Each | 260 |
| 9.12.4 | 40X32mm | Each | 559 |
| 9.12.5 | 50x40mm | Each | 749 |
| 9.12.6 | 63x50mm | Each | 1152 |
| 9.13 | Providing & Supplying of Clamp Saddle (DI Strap Saddle) for House Service connections from metal pipe water distribution mains shall be of fastened strap type with threaded outlet for service connection. Clamp Saddle shall be suitable for nominal size of distribution mains pipe line. The strap shall be elastomer coated (insulated) type for firm grip on pipe as well as to protect the coating on the pipe and to insulate the unidentical metals. The saddle shall be single strap type up to pipe sizes of NB 600 and service outlet 15mm, 20mm & 25mm. Fasteners shall be of threaded nut bolt washer type. The sealing between the saddle and mains shall be obtained by using a profiled elastomer seal matching to the curvature of the pipe. The seal shall be of elastomer type, suitable for all potable water application. The material of construction of the body, straps, fasteners etc. shall be of non-corrosive material such as engineering plastic (PE/PP) or stainless steel or a combination of both. and shall be inclusive of all cost such as testing, | | |

| S.No. | Items | Unit | Rates in Rs. |
|-----------|--|------|--------------|
| | inspection charges, transportation up to site, transit insurance, loading, unloading, stacking etc. complete. | | |
| 9.13.1 | 80 NB x 15mm, 20mm, 25mm | Each | 1017 |
| 9.13.2 | 100 NB x 15mm, 20mm, 25mm | Each | 1118 |
| 9.13.3 | 150 NB x 15mm, 20mm, 25mm | Each | 1322 |
| 9.13.4 | 200 NB x 15mm, 20mm, 25mm | Each | 1525 |
| 9.13.5 | 250 NB x 15mm, 20mm, 25mm | Each | 1729 |
| 9.13.6 | 300 NB x 15mm, 20mm, 25mm | Each | 1932 |
| 9.14 | Providing & Supply of Electro Fusion Fittings in accordance with BS EN 12201 : Part-3 suitable for drinking water with in black/blue color manufactured from compounded PE80/PE100 virgin polymer and compatible with PE80/PE100 pipes, in pressure rated SDR 11 with min PN 12.5 rated for water application and shall be inclusive of all cost such as testing, inspection charges, transportation up to site, transit insurance, loading, unloading, stacking etc. complete. | | |
| 9.14.1 | Electro Fusion Coupler | | |
| 9.14.1.1 | 20mm | Each | 102 |
| 9.14.1.2 | 25mm | Each | 102 |
| 9.14.1.3 | 32mm | Each | 102 |
| 9.14.1.4 | 40mm | Each | 188 |
| 9.14.1.5 | 50mm | Each | 233 |
| 9.14.1.6 | 63mm | Each | 251 |
| 9.14.1.7 | 75mm | Each | 451 |
| 9.14.1.8 | 90mm | Each | 484 |
| 9.14.1.9 | 110mm | Each | 689 |
| 9.10.1.10 | 125mm | Each | 701 |
| 9.14.1.11 | 140mm | Each | 1503 |
| 9.14.1.12 | 160mm | Each | 1647 |
| 9.14.1.13 | 180mm | Each | 2460 |
| 9.14.1.14 | 200mm | Each | 3211 |
| 9.14.1.15 | 225mm | Each | 3812 |
| 9.14.1.16 | 250mm | Each | 4645 |
| 9.14.1.17 | 280mm | Each | 9307 |

| S.No. | Items | Unit | Rates in Rs. |
|--------------|---------------------------------|-------------|---------------------|
| 9.14.1.18 | 315mm | Each | 9340 |
| 9.14.2 | Electro Fusion Equal Tee | | |
| 9.14.2.1 | 20mm | Each | 254 |
| 9.14.2.2 | 25mm | Each | 254 |
| 9.14.2.3 | 32mm | Each | 254 |
| 9.14.2.4 | 40mm | Each | 862 |
| 9.14.2.5 | 50mm | Each | 958 |
| 9.14.2.6 | 63mm | Each | 1068 |
| 9.14.2.7 | 75mm | Each | 1424 |
| 9.14.2.8 | 90mm | Each | 1769 |
| 9.14.2.9 | 110mm | Each | 2135 |
| 9.14.2.10 | 125mm | Each | 2644 |
| 9.14.2.11 | 140mm | Each | 5991 |
| 9.14.2.12 | 160mm | Each | 8744 |
| 9.14.2.13 | 180mm | Each | 11185 |
| 9.14.2.14 | 200mm | Each | 13218 |
| 9.14.2.15 | 225mm | Each | 19319 |
| 9.14.2.16 | 250mm | Each | 21353 |
| 9.14.2.17 | 280mm | Each | 23386 |
| 9.14.3 | Electro Fusion Elbow 90° | | |
| 9.14.3.1 | 20mm | Each | 193 |
| 9.14.3.2 | 25mm | Each | 193 |
| 9.14.3.3 | 32mm | Each | 193 |
| 9.14.3.4 | 40mm | Each | 508 |
| 9.14.3.5 | 50mm | Each | 508 |
| 9.14.3.6 | 63mm | Each | 508 |
| 9.14.3.7 | 75mm | Each | 1118 |
| 9.14.3.8 | 90mm | Each | 1525 |
| 9.14.3.9 | 110mm | Each | 2034 |
| 9.14.3.10 | 125mm | Each | 2440 |
| 9.14.3.11 | 140mm | Each | 5186 |
| 9.14.3.12 | 160mm | Each | 6711 |
| 9.14.3.13 | 180mm | Each | 8643 |
| 9.14.3.14 | 200mm | Each | 16269 |
| 9.14.3.15 | 225mm | Each | 18302 |
| 9.14.3.16 | 250mm | Each | 20336 |

| S.No. | Items | Unit | Rates in Rs. |
|--------------|-------------------------------|-------------|---------------------|
| 9.14.3.17 | 280mm | Each | 22369 |
| 9.14.3.18 | 315mm | Each | 25420 |
| 9.16.4 | Electro Fusion Reducer | | |
| 9.14.4.1 | 25x20mm | Each | 203 |
| 9.14.4.2 | 32x20mm | Each | 203 |
| 9.14.4.3 | 32x25mm | Each | 203 |
| 9.14.4.4 | 40x32mm | Each | 681 |
| 9.14.4.5 | 50x32mm | Each | 854 |
| 9.14.4.6 | 50x40mm | Each | 944 |
| 9.14.4.7 | 63x32mm | Each | 1007 |
| 9.14.4.8 | 63x40mm | Each | 1018 |
| 9.14.4.9 | 63x50mm | Each | 1179 |
| 9.14.4.10 | 90x63mm | Each | 1669 |
| 9.14.4.11 | 90x75mm | Each | 2135 |
| 9.14.4.12 | 110x75mm | Each | 2694 |
| 9.14.4.13 | 110x90mm | Each | 3071 |
| 9.14.4.14 | 125x90mm | Each | 3884 |
| 9.14.4.15 | 125x110mm | Each | 3884 |
| 9.14.4.16 | 140x90mm | Each | 4271 |
| 9.14.4.17 | 140x110mm | Each | 4271 |
| 9.14.4.18 | 140x125mm | Each | 4271 |
| 9.14.4.19 | 160x110mm | Each | 5592 |
| 9.14.4.20 | 160x125mm | Each | 5592 |
| 9.14.4.21 | 160x140mm | Each | 5592 |
| 9.14.4.22 | 180x125mm | Each | 6304 |
| 9.14.4.23 | 180x140mm | Each | 6304 |
| 9.14.4.24 | 180x160mm | Each | 6304 |
| 9.14.4.25 | 200x160mm | Each | 7524 |
| 9.14.4.26 | 200x180mm | Each | 7524 |
| 9.14.4.27 | 225x160mm | Each | 9151 |
| 9.14.4.28 | 225x180mm | Each | 9151 |
| 9.14.4.29 | 225x200mm | Each | 9151 |
| 9.14.4.30 | 250x160mm | Each | 11185 |
| 9.14.4.31 | 250x200mm | Each | 11185 |
| 9.14.4.32 | 250x225mm | Each | 11185 |
| 9.14.5 | Electro Fusion End Cap | | |
| 9.14.5.1 | 20mm | Each | 155 |

| S.No. | Items | Unit | Rates in Rs. |
|--------------|--|-------------|---------------------|
| 9.14.5.2 | 25mm | Each | 155 |
| 9.14.5.3 | 32mm | Each | 155 |
| 9.14.5.4 | 40mm | Each | 336 |
| 9.14.5.5 | 50mm | Each | 407 |
| 9.14.5.6 | 63mm | Each | 590 |
| 9.14.5.7 | 75mm | Each | 885 |
| 9.14.5.8 | 90mm | Each | 1118 |
| 9.14.5.9 | 110mm | Each | 1424 |
| 9.14.5.10 | 125mm | Each | 1729 |
| 9.14.5.11 | 140mm | Each | 2542 |
| 9.14.5.12 | 160mm | Each | 3660 |
| 9.14.5.13 | 180mm | Each | 4474 |
| 9.14.5.14 | 200mm | Each | 5287 |
| 9.14.5.15 | 225mm | Each | 8643 |
| 9.14.5.16 | 250mm | Each | 10168 |
| 9.14.5.17 | 280mm | Each | 11185 |
| 9.14.5.18 | 315mm | Each | 12201 |
| 9.14.6 | Spigot Long Neck Pipe End (Stub End) for Electro Fusion Joint | | |
| 9.14.6.1 | 63mm | Each | 364 |
| 9.14.6.2 | 75mm | Each | 410 |
| 9.14.6.3 | 90mm | Each | 513 |
| 9.14.6.4 | 110mm | Each | 783 |
| 9.14.6.5 | 125mm | Each | 1233 |
| 9.14.6.6 | 140mm | Each | 1403 |
| 9.14.6.7 | 160mm | Each | 2008 |
| 9.14.6.8 | 180mm | Each | 2708 |
| 9.14.6.9 | 200mm | Each | 3183 |
| 9.14.6.10 | 225mm | Each | 3818 |
| 9.14.6.11 | 250mm | Each | 4385 |
| 9.14.6.12 | 280mm | Each | 4909 |
| 9.14.6.13 | 315mm | Each | 6380 |

CHAPTER- X

MILD STEEL PIPES AND SPECIALS

CHAPTER – X

MILD STEEL PIPES AND SPECIALS

NOTES :

1. This Specification covers the requirements for manufacturing, supplying, laying, jointing, testing at worksite of Electrically Welded Steel pipes, internally lined with cement concrete and externally coated with cement mortar, used for water supply mains.

2. **Applicable Codes**

IS : 3589 Seamless/Electrically Welded Steel Pipes for Water, Gas, Sewage Specification

IS:5822 Code of Practice for laying of Electrically Welded Steel Pipes for Water Supply.

IS : 7322 Specification for Specials for Steel Cylinder Reinforced Concrete Pipes

IS:432 Mild Steel and Medium Tensile Bars Reinforcement Part I

IS:432 Specifications for Mild Steel and Medium Tensile Bars and Hard Drawn Steel Wire (Third Revision) Part II

IS:2328 Flattening Test for Seamless Pipes

IS : 12269 Specification for 53 Grade Ordinary Portland Cement (OPC)

IS:6452 Specification for High Alumina Cement for Structural Use (1st Revision)

IS : 8112 Specification for Curing of High Strength OPC

IS : 8041 Specifications for Curing of Rapid Hardening Cement

IS:269 Specifications for Ordinary Portland Cement (OPC)

IS:455 Specifications for Portland Slag Cement

IS : 1489 Specifications for Portland Pozzolana Cement

IS : 8043 Specifications for Hydrophobic Portland Cement

IS : 3600 Methods of Testing Fusion Welded Joints and Weld Metal in Steel cylinder pipes with concrete lining and crating (specifications)

Part I

Steel :

Other I.S. Codes not specifically mentioned here but pertaining to the use of Electrically Welded Steel pipes shall form part of these Specifications.

3. The preferred outside Diameter and thickness of the pipes shall be as per the Table -1 of IS : 1916:1969
4. Length: The pipes shall be manufactured in lengths of 6m, unless otherwise specified.
5. Welding: For manufacturing of the site pipes, the welding & testing should comply with IS: 816.

6. Fabrication of specials: Specials such as bends, tapers, tees shall Conform to IS: 7322, Specials shall be fabricated by cutting plates of the specified thickness to the required shape obtained by developing the form of specials onground.

7. Measurement:

The net length of pipes as laid or fixed should be measured in running meters correct to a fraction of the decimal. Specials should be excluded and enumerated and paid for separately. The portion of the pipe within the collar at the joints shall not be included in the length of pipe work.

8. Rates

The rates include charges for all tools & plants, required for lifting and laying the pipes and specials in positions as per approved drawing and specifications.

The rates include provision and use of all coverings etc. to protect the works from inclement weather etc. and from damages from fall of materials, and other causes.

9. The rates shown in item are exclusive of the cost of any type of coating but dimensionally suitable for internal epoxy lining. In case of inside cement mortar lining extra weight of shell shall be adjusted at the rate of Rs. 82.00 (Eighty two only) per kg according to the following factor.

$$\text{Extra mass per meter length of pipe} = t_c \times t \times 0.01233$$

Where in t_c = Cement mortar coating thickness in mm

t = Shell thickness in mm

10. The estimate rates for pipe using steel plate (shell) thickness other than mentioned in item shall be adjusted to the rate of Rs. 82.00 per kg for deffered thickness.

11 This USOR contains the rates of all the items without GST. No claims against GST shall be entertained at any level. GST shall be paid by the Agency/ Contractor directly to the concerning department. Howerer, All the estimates prepared on this USOR will include GST, as an extra amount as per prevailing rates on the sum of the estimate to arrive at the gross amount.

M.S. PIPES AND SPECIALS

| S. No. | Item | Unit | Rate (in Rs.) |
|--------|---|------|---------------|
| 10.1 | Manufacturing, Supplying at site & laying, jointing of following M.S. pipes as per IS specifications, duly testing for usage in Drinking water inclusive of all materials, inspection charges, transit insurance, loading/unloading, FOR site and stacking etc. complete as per direction of Engineer-in-Charge. (Excluding protective coating) | | |

| S. No. | Item | Unit | Rate (in Rs.) |
|---------------|---|-------------|----------------------|
| 10.1.1 | Dia of pipe 100.00 mm (I.D) Thickness of pipe | | |
| (i) | 4mm | RM | 682 |
| (ii) | 6mm | RM | 1047 |
| (iii) | 8mm | RM | 1428 |
| 10.1.2 | Dia of pipe 150.00 mm (I.D) Thickness of pipe | | |
| (i) | 4mm | RM | 1011 |
| (ii) | 6mm | RM | 1540 |
| (iii) | 8mm | RM | 2088 |
| 10.1.3 | Dia of pipe 200.00 mm (I.D) Thickness of pipe | | |
| (i) | 4mm | RM | 1339 |
| (ii) | 6mm | RM | 2035 |
| (iii) | 8mm | RM | 2748 |
| 10.1.4 | Dia of pipe 250.00 mm (I.D) Thickness of pipe | | |
| (i) | 4mm | RM | 1667 |
| (ii) | 6mm | RM | 2528 |
| (iii) | 8mm | RM | 3409 |
| 10.1.5 | Dia of pipe 300.00 mm (I.D) Thickness of pipe : | | |
| (i) | 4mm | RM | 1995 |
| (ii) | 6mm | RM | 3022 |
| (iii) | 8mm | RM | 4070 |
| 10.1.6 | Dia of pipe 350.00 mm (I.D) Thickness of pipe : | | |
| (i) | 4mm | RM | 2322 |
| (ii) | 6mm | RM | 3515 |
| (iii) | 8mm | RM | 4730 |
| 10.1.7 | Dia of pipe 400.00 mm (I.D) Thickness of pipe : | | |
| (i) | 4mm | RM | 2651 |
| (ii) | 6mm | RM | 4009 |
| (iii) | 8mm | RM | 5391 |
| (iv) | 10mm | RM | 6765 |
| 10.1.8 | Dia of pipe 450.00 mm (I.D) Thickness of pipe : | | |
| (i) | 4mm | RM | 2979 |
| (ii) | 6mm | RM | 4503 |
| (iii) | 8mm | RM | 6051 |
| (iv) | 10mm | RM | 7589 |
| 10.1.9 | Dia of pipe 500.00 mm (I.D) Thickness of pipe : | | |
| (i) | 5mm | RM | 4122 |
| (ii) | 6mm | RM | 4997 |
| (iii) | 8mm | RM | 6712 |
| (iv) | 10mm | RM | 8415 |
| (v) | 12mm | RM | 10189 |
| 10.1.10 | Dia of pipe 550.00 mm (I.D) Thickness of pipe | | |
| (i) | 5mm | RM | 4530 |
| (ii) | 6mm | RM | 5491 |
| (iii) | 8mm | RM | 7373 |
| (iv) | 10mm | RM | 9240 |

| S. No. | Item | Unit | Rate (in Rs.) |
|---------------|--|-------------|----------------------|
| (v) | 12mm | RM | 11184 |
| 10.1.11 | Dia of pipe 600.00 mm (I.D) Thickness of pipe : | | |
| (i) | 6mm | RM | 5984 |
| (ii) | 8mm | RM | 8033 |
| (iii) | 10mm | RM | 10063 |
| (iv) | 12mm | RM | 12179 |
| 10.1.12 | Dia of pipe 650.00 mm (I.D) Thickness of pipe | | |
| (i) | 6mm | RM | 6478 |
| (ii) | 8mm | RM | 8592 |
| (iii) | 10mm | RM | 10889 |
| (iv) | 12mm | RM | 13174 |
| 10.1.13 | Dia of pipe 700.00 mm (I.D) Thickness of pipe : | | |
| (i) | 6mm | RM | 6971 |
| (ii) | 8mm | RM | 9353 |
| (iii) | 10mm | RM | 11713 |
| (iv) | 12mm | RM | 14168 |
| (v) | 14mm | RM | 16491 |
| 10.1.14 | Dia of pipe 750.00 mm (I.D) Thickness of pipe : | | |
| (i) | 7mm | RM | 8686 |
| (ii) | 8mm | RM | 10014 |
| (iii) | 10mm | RM | 12538 |
| (iv) | 12mm | RM | 15162 |
| 10.1.15 | Dia of pipe 800.00 mm (I.D) Thickness of pipe : | | |
| (i) | 7mm | RM | 9260 |
| (ii) | 8mm | RM | 10675 |
| (iii) | 10mm | RM | 13364 |
| (iv) | 12mm | RM | 16158 |
| 10.1.16 | Dia of pipe 850.00 mm (I.D) Thickness of pipe : | | |
| (i) | 8mm | RM | 11335 |
| (ii) | 10mm | RM | 14188 |
| (iii) | 12mm | RM | 17152 |
| 10.1.17 | Dia of pipe 900.00 mm (I.D) Thickness of pipe : | | |
| (i) | 8mm | RM | 11996 |
| (ii) | 10mm | RM | 15013 |
| (iii) | 12mm | RM | 18147 |
| 10.1.18 | Dia of pipe 950.00 mm (I.D) Thickness of pipe : | | |
| (i) | 8mm | RM | 12656 |
| (ii) | 10mm | RM | 15838 |
| (iii) | 12mm | RM | 19141 |
| 10.1.19 | Dia of pipe 1000.00 mm (I.D) Thickness of pipe : | | |
| (i) | 8mm | RM | 13317 |
| (ii) | 10mm | RM | 16662 |
| (iii) | 12mm | RM | 20137 |
| 10.1.20 | Dia of pipe 1050.00 mm (I.D) Thickness of pipe : | | |
| (i) | 8mm | RM | 13978 |

| S. No. | Item | Unit | Rate (in Rs.) |
|---------------|--|-------------|----------------------|
| (ii) | 10mm | RM | 17487 |
| (iii) | 12mm | RM | 21131 |
| 10.1.21 | Dia of pipe 1100.00 mm (I.D) Thickness of pipe : | | |
| (i) | 10mm | RM | 18312 |
| (ii) | 12mm | RM | 22126 |
| 10.1.22 | Dia of pipe 1150.00 mm (I.D) Thickness of pipe : | | |
| (i) | 10mm | RM | 19137 |
| (ii) | 12mm | RM | 23121 |
| 10.1.23 | Dia of pipe 1200.00 mm (I.D) Thickness of pipe : | | |
| (i) | 10mm | RM | 19962 |
| (ii) | 12mm | RM | 24115 |
| 10.1.24 | Dia of pipe 1250.00 mm (I.D) Thickness of pipe : | | |
| (i) | 10mm | RM | 20786 |
| (ii) | 12mm | RM | 25110 |
| 10.1.25 | Dia of pipe 1300.00 mm (I.D) Thickness of pipe : | | |
| (i) | 10mm | RM | 21611 |
| (ii) | 12mm | RM | 26104 |
| 10.1.26 | Dia of pipe 1350.00 mm (I.D) Thickness of pipe : | | |
| (i) | 10mm | RM | 22435 |
| (ii) | 12mm | RM | 27099 |
| 10.1.27 | Dia of pipe 1400.00 mm (I.D) Thickness of pipe : | | |
| (i) | 12mm | RM | 28094 |
| (ii) | 14mm | RM | 3550 |
| 10.1.28 | Dia of pipe 1450.00 mm (I.D) Thickness of pipe : | | |
| (i) | 12mm | RM | 29088 |
| (ii) | 14mm | RM | 33810 |
| 10.1.29 | Dia of pipe 1500.00 mm (I.D) Thickness of pipe : | | |
| (i) | 12mm | RM | 30083 |
| (ii) | 14mm | RM | 34964 |
| 10.1.30 | Dia of pipe 1550.00 mm (I.D) Thickness of pipe : | | |
| (i) | 12mm | RM | 31078 |
| (ii) | 14mm | RM | 36119 |
| 10.1.31 | Dia of pipe 1600.00 mm (I.D) Thickness of pipe : | | |
| (i) | 14mm | RM | 37273 |
| (ii) | 16mm | RM | 42488 |
| 10.1.32 | Dia of pipe 1650.00 mm (I.D) Thickness of pipe : | | |
| (i) | 14mm | RM | 38429 |
| (ii) | 16mm | RM | 43802 |
| (iii) | 18mm | RM | 49189 |
| 10.1.33 | Dia of pipe 1700.00 mm (I.D) Thickness of pipe : | | |
| (i) | 14mm | RM | 39583 |
| (ii) | 16mm | RM | 45117 |
| (iii) | 18mm | RM | 50664 |
| 10.1.34 | Dia of pipe 1750.00 mm (I.D) Thickness of pipe | | |
| (i) | 14mm | RM | 40738 |

| S. No. | Item | Unit | Rate (in Rs.) |
|---------------|---|-------------|----------------------|
| (ii) | 16mm | RM | 46431 |
| (iii) | 18mm | RM | 52138 |
| 10.1.35 | Dia of pipe 1800.00 mm (I.D) Thickness of pipe : | | |
| (i) | 14mm | RM | 41892 |
| (ii) | 16mm | RM | 47745 |
| (iii) | 18mm | RM | 53612 |
| 10.1.36 | Dia of pipe 1850.00 mm (I.D) Thickness of pipe : | | |
| (i) | 14mm | RM | 43047 |
| (ii) | 16mm | RM | 49060 |
| (iii) | 20mm | RM | 61126 |
| 10.1.37 | Dia of pipe 1900.00 mm (I.D) Thickness of pipe : | | |
| (i) | 16mm | RM | 50375 |
| (ii) | 18mm | RM | 56561 |
| (iii) | 20mm | RM | 62761 |
| 10.1.38 | Dia of pipe 1950.00 mm (I.D) Thickness of pipe : | | |
| (i) | 16mm | RM | 51689 |
| (ii) | 18mm | RM | 58035 |
| (iii) | 20mm | RM | 64395 |
| 10.1.39 | Dia of pipe 2000.00 mm (I.D) Thickness of pipe : | | |
| (i) | 16mm | RM | 53003 |
| (ii) | 18mm | RM | 59510 |
| (iii) | 20mm | RM | 66029 |
| | FABRICATION OF M.S. PIPE AND SPECIALS | | |
| 10.2 | Fabrication of M.S. pipes & specials from steel plates as per relevant IS specifications inclusive of cost of all materials, for any thickness as per design, inspection charges, testing, transit insurance, loading/ unloading, FOR site and stacking etc. complete as per direction of the Engineer in charge. fabricating of pipes and specials from steel plates. | Kg. | 74 |
| 10.3 | Labour only for lowering and laying of MS pipe and specials as per approved specification complete as directed by Engineer in charge | Kg | 1 |
| 10.4 | Providing and applying primer and one coat of red oxide externally | Sqm | 34 |
| 10.5 | Providing and applying primer and one coat of red oxide of iron paint, internally | Sqm | 72 |
| | Laying of M.S. Pipes and Specials | | |
| 10.6 | Labour Only for lowering & laying of M.S. Pipes as per approved specification and as directed by Engineer in charge. | | |
| 10.6.1 | 4mm to 8mm thick | | |

| S. No. | Item | Unit | Rate (in Rs.) |
|--------|--|------|---------------|
| | 100mm Upto 500mm. dia | RM | 72 |
| | Above 500mm. Upto 750mm. dia | RM | 118 |
| | Above 750mm. Upto 1050mm. dia | RM | 163 |
| 10.6.2 | 10mm to 12mm thick | | |
| | 400mm Upto 750mm. dia | RM | 194 |
| | Above 750mm. Upto 1050mm. dia | RM | 268 |
| | Above 1050mm. Upto 1200mm. dia | RM | 335 |
| | Above 1200mm. Upto 1550mm. dia | RM | 401 |
| 10.6.3 | 14mm to 20mm thick | | |
| | Above 700mm. Upto 1000mm. dia | RM | 319 |
| | Above 1000mm. Upto 1250mm. dia | RM | 399 |
| | Above 1250mm. Upto 1450mm. dia | RM | 476 |
| | Above 1450mm. Upto 1750mm. dia | RM | 563 |
| | Above 1750mm. Upto 2000mm. dia | RM | 660 |
| 10.7 | Providing rigid welded joint to the following MS pipes including testing of joints and cost of jointing material as per relevant approved specification complete. | | |
| 10.7.1 | Dia of pipe 250.00 mm (I.D) Thickness of pipe : | | |
| (i) | 4mm | RM | 56 |
| (ii) | 6mm | RM | 114 |
| (iii) | 8mm | RM | 238 |
| 10.7.2 | Dia of pipe 300.00 mm (I.D) Thickness of pipe : | | |
| (i) | 4mm | RM | 66 |
| (ii) | 6mm | RM | 135 |
| (iii) | 8mm | RM | 274 |
| 10.7.3 | Dia of pipe 350.00 mm (I.D) Thickness of pipe : | | |
| (i) | 4mm | RM | 77 |
| (ii) | 6mm | RM | 158 |
| (iii) | 8mm | RM | 327 |
| 10.7.4 | Dia of pipe 400.00 mm (I.D) Thickness of pipe : | | |
| (i) | 4mm | RM | 87 |
| (ii) | 6mm | RM | 179 |
| (iii) | 8mm | RM | 372 |
| (iv) | 10mm | RM | 458 |
| 10.7.5 | Dia of pipe 450.00 mm (I.D) Thickness of pipe : | | |
| (i) | 4mm | RM | 99 |
| (ii) | 6mm | RM | 201 |
| (iii) | 8mm | RM | 418 |
| (iv) | 10mm | RM | 512 |
| 10.7.6 | Dia of pipe 500.00 mm (I.D) Thickness of pipe : | | |
| (i) | 5mm | RM | 110 |
| (ii) | 6mm | RM | 223 |
| (iii) | 8mm | RM | 463 |
| (iv) | 10mm | RM | 567 |

| S. No. | Item | Unit | Rate (in Rs.) |
|---------------|---|-------------|----------------------|
| (v) | 12mm | RM | 1020 |
| 10.7.7 | Dia of pipe 550.00 mm (I.D) Thickness of pipe : | | |
| (i) | 5mm | RM | 121 |
| (ii) | 6mm | RM | 246 |
| (iii) | 8mm | RM | 507 |
| (iv) | 10mm | RM | 621 |
| (v) | 12mm | RM | 1116 |
| 10.7.8 | Dia of pipe 600.00 mm (I.D) Thickness of pipe : | | |
| (i) | 6mm | RM | 267 |
| (ii) | 8mm | RM | 552 |
| (iii) | 10mm | RM | 676 |
| (iv) | 12mm | RM | 1214 |
| 10.7.9 | Dia of pipe 650.00 mm (I.D) Thickness of pipe : | | |
| (i) | 6mm | RM | 289 |
| (ii) | 8mm | RM | 597 |
| (iii) | 10mm | RM | 730 |
| (iv) | 12mm | RM | 1311 |
| 10.7.10 | Dia of pipe 700.00 mm (I.D) Thickness of pipe : | | |
| (i) | 6mm | RM | 311 |
| (ii) | 8mm | RM | 642 |
| (iii) | 10mm | RM | 785 |
| (iv) | 12mm | RM | 1408 |
| (v) | 14mm | RM | 1416 |
| 10.7.11 | Dia of pipe 750.00 mm (I.D) Thickness of pipe : | | |
| (i) | 7mm | RM | 334 |
| (ii) | 8mm | RM | 686 |
| (iii) | 10mm | RM | 839 |
| (iv) | 12mm | RM | 1506 |
| 10.7.12 | Dia of pipe 800.00 mm (I.D) Thickness of pipe : | | |
| (i) | 7mm | RM | 356 |
| (ii) | 8mm | RM | 730 |
| (iii) | 10mm | RM | 894 |
| (iv) | 12mm | RM | 1709 |
| 10.7.13 | Dia of pipe 850.00 mm (I.D) Thickness of pipe : | | |
| (i) | 8mm | RM | 775 |
| (ii) | 10mm | RM | 948 |
| (iii) | 12mm | RM | 1701 |
| 10.7.14 | Dia of pipe 900.00 mm (I.D) Thickness of pipe : | | |
| (i) | 8mm | RM | 820 |
| (ii) | 10mm | RM | 1003 |
| (iii) | 12mm | RM | 1776 |
| 10.7.15 | Dia of pipe 950.00 mm (I.D) Thickness of pipe : | | |
| (i) | 8mm | RM | 865 |
| (ii) | 10mm | RM | 1057 |
| (iii) | 12mm | RM | 1895 |

| S. No. | Item | Unit | Rate (in Rs.) |
|---------|--|------|---------------|
| 10.7.16 | Dia of pipe 1000.00 mm (I.D) Thickness of pipe | | |
| (i) | 8mm | RM | 910 |
| (ii) | 10mm | RM | 1111 |
| (iii) | 12mm | RM | 1992 |
| 10.7.17 | Dia of pipe 1050.00 mm (I.D) Thickness of pipe : | | |
| (i) | 8mm | RM | 955 |
| (ii) | 10mm | RM | 1166 |
| (iii) | 12mm | RM | 2090 |
| 10.7.18 | Dia of pipe 1100.00 mm (I.D) Thickness of pipe : | | |
| (i) | 10mm | RM | 1221 |
| (ii) | 12mm | RM | 2186 |
| 10.7.19 | Dia of pipe 1150.00 mm (I.D) Thickness of pipe : | | |
| (i) | 10mm | RM | 1276 |
| (ii) | 12mm | RM | 2284 |
| 10.7.20 | Dia of pipe 1200.00 mm (I.D) Thickness of pipe : | | |
| (i) | 10mm | RM | 1330 |
| (ii) | 12mm | RM | 2381 |
| 10.7.21 | Dia of pipe 1250.00 mm (I.D) Thickness of pipe : | | |
| (i) | 10mm | RM | 1385 |
| (ii) | 12mm | RM | 2478 |
| 10.7.22 | Dia of pipe 1300.00 mm (I.D) Thickness of pipe : | | |
| (i) | 10mm | RM | 1439 |
| (ii) | 12mm | RM | 2576 |
| 10.7.23 | Dia of pipe 1350.00 mm (I.D) Thickness of pipe : | | |
| (i) | 10mm | RM | 1494 |
| (ii) | 12mm | RM | 2673 |
| 10.7.24 | Dia of pipe 1400.00 mm (I.D) Thickness of pipe : | | |
| (i) | 12mm | RM | 2771 |
| (ii) | 14mm | RM | 2778 |
| 10.7.25 | Dia of pipe 1450.00 mm (I.D) Thickness of pipe : | | |
| (i) | 12mm | RM | 2867 |
| (ii) | 14mm | RM | 2875 |
| 10.7.26 | Dia of pipe 1500.00 mm (I.D) Thickness of pipe : | | |
| (i) | 12mm | RM | 2965 |
| (ii) | 14mm | RM | 2972 |
| 10.7.27 | Dia of pipe 1550.00 mm (I.D) Thickness of pipe : | | |
| (i) | 12mm | RM | 3062 |
| (ii) | 14mm | RM | 3070 |
| 10.7.28 | Dia of pipe 1600.00 mm (I.D) Thickness of pipe : | | |
| (i) | 14mm | RM | 3166 |
| (ii) | 16mm | RM | 3175 |
| 10.7.29 | Dia of pipe 1650.00 mm (I.D) Thickness of pipe | | |
| (i) | 14mm | RM | 3265 |
| (ii) | 16mm | RM | 3272 |
| (iii) | 18mm | RM | 3280 |

| S. No. | Item | Unit | Rate (in Rs.) |
|---------------|---|-------------|----------------------|
| 10.7.30 | Dia of pipe 1700.00 mm (I.D) Thickness of pipe : | | |
| (i) | 14mm | RM | 3362 |
| (ii) | 16mm | RM | 3370 |
| (iii) | 18mm | RM | 3377 |
| 10.7.31 | Dia of pipe 1750.00 mm (I.D) Thickness of pipe : | | |
| (i) | 14mm | RM | 3459 |
| (ii) | 16mm | RM | 3466 |
| (iii) | 18mm | RM | 3474 |
| 10.7.32 | Dia of pipe 1800.00 mm (I.D) Thickness of pipe : | | |
| (i) | 14mm | RM | 3557 |
| (ii) | 16mm | RM | 3564 |
| (iii) | 18mm | RM | 3571 |
| 10.7.33 | Dia of pipe 1850.00 mm (I.D) Thickness of pipe : | | |
| (i) | 14mm | RM | 3653 |
| (ii) | 16mm | RM | 3660 |
| (iii) | 20mm | RM | 3677 |
| 10.7.34 | Dia of pipe 1900.00 mm (I.D) Thickness of pipe : | | |
| (i) | 16mm | RM | 3758 |
| (ii) | 18mm | RM | 3766 |
| (iii) | 20mm | RM | 3774 |
| 10.7.35 | Dia of pipe 1950.00 mm (I.D) Thickness of pipe | | |
| (i) | 16mm | RM | 3856 |
| (ii) | 18mm | RM | 3864 |
| (iii) | 20mm | RM | 3444 |
| 10.7.36 | Dia of pipe 2000.00 mm (I.D) Thickness of pipe : | | |
| (i) | 16mm | RM | 3953 |
| (ii) | 20mm | RM | 3969 |
| 10.8 | Providing & applying 30 mm thick 1:3 cement mortar coating out side face of M.S pipe as per relevant IS specification including testing along with fixing of (100 x3 mm) wire meshas per approved specification per Sqmm | Sqm | 437 |
| 10.9 | Providing & applying inside 20 mm thick 1:2 cement mortar on inside face of pipe as per relevant IS specification including testing as directed by Engineer in Charge | Sqm | 320 |
| 10.10 | Providing & applying 400 micron epoxy coating as per relevant IS specification on out side face of pipe including testing. | Sqm | 146 |
| 10.11 | Providing & applying 400 micron food grade epoxy coating on inside face of pipe as per relevant IS specification including testing. | Sqm | 229 |

CHAPTER- XI

BAR WRAPPED STEEL CYLINDER PIPES (BWSC)

CHAPTER-XI

BAR WRAPPED STEEL CYLINDER PIPES (BWSC)

NOTES :

1. Scope

This specification covers the requirements for design, manufacturing, testing, supplying, laying, jointing, welding and testing at works and site of Bar Wrapped Steel Cylinder (BWSC) Pipes used for water supply mains.

2. Applicable Codes

IS:226 Specifications for structural Steel (Standard Quality)

IS:383 Specifications for coarse and fine aggregates from natural sources for concrete.

IS:432 Specifications for mild steel and medium tensile steel bar/wires for concrete reinforcement.

Part1 Mild Steel and medium tensile steel bar/wires

Part2 Hard drawn steel wire

IS:1566 Specifications for Hard Drawn Steel Wire for Concrete Reinforcement

IS:2062 Specifications for Steel for General Structural Purposes

IS:3597 Methods of Test for Concrete Pipes

IS:3658 Code of Practice for liquid penetrant flaw detection

IS:5822 Code of Practice for laying of Electrically Welded Steel Pipes for Water Supply

IS:7322 Specifications for Specials for Steel Cylinder Reinforced Concrete pipes

IS:15155 Specifications for Bar Wrapped steel Cylinder Pipes (including Fittings)

AWWA Manual M-9 Concrete pressure pipe

EN641 Reinforced Concrete Pressure Pipe, Cylinder Type, including Joints & fittings.

Other I.S. Codes not specifically mentioned here but pertaining to the use of BWSC pipes form part of these Specifications.

3. Design Criteria

The reinforcement of the pipe shall consist of a welded steel cylinder and bar/wire is directly wrapped under low tension. The average circumferential stress in the steel cylinder and bar/wire reinforcement of the pipe shall be as given below:-

At factory test pressure, stress shall not exceed 187 N/mm^2 nor 75 percent of the minimum yield strength of the steel used in the cylinder.

At site test pressure, stress shall neither exceed 165 N/mm^2 nor 75 percent of the minimum yield strength of the steel used in the cylinder.

At working pressure, stress shall not exceed 125 N/mm^2 nor 50 percent of the minimum yield strength of the steel used in the cylinder.

4. **Preparing Pipe faces for Welding:** Before aligning, assembling and welding, the pipe faces shall be cleaned by scrapping by wire brushes or any other method specified by the authority.
5. **Welding:** Generally the welding of pipe in the field should comply with IS 816: 1969.

5.1 For field welding rates applicable for similar welding in M.S. Pipes, shall be adopted.

6. **Internal Diameter:** The internal diameter shall be measured at each end of the pipe at approximately 50mm from the ends. Two measurements of the internal diameter at 90° to each other shall be made at each end and centre. The internal diameter shall be maintained within the tolerances specified.
7. **Wall Thickness:** Measurement of outside circumference of the pipe shall be made at three positions and average outside diameter of the pipe shall be calculated. The inside diameter shall be measured at three positions and average shall be calculated.

8. **Specials and Fittings**

8.1 The steel for fabricated steel plate specials, in cut, shaped and welded so that finished special has the required shape and internal dimensions. Adjacent segments are jointed by butt welding. Before lining and coating the welding of special shall be tested by use of hot oil or dye penetrant according to IS 3658 and defects, if any shall be rectified. The steel plate thickness for specials shall be as given in IS: 7322.

8.2 All the specials shall be tested for hydrostatic pressure as specified for BWSC pipes and to the pressure specified for pipes in the reaches where the specials are fitted.

9. For lowering, laying & pouring of cement mortar in the field on joints (after laying & welding) rate as per P.S.C. pipes Lowering, laying & jointing shall be adopted.
10. When ever manufacturer is separate and contractor for lowering, laying, jointing & testing are different, the principal contractor shall enter in to the agreement with BWSC pipe manufacturer for satisfactory manufacturing, transporting, lowering, laying, jointing and testing of pipe.

11. Measurement:

The net length of pipes as laid or fixed shall be measured in running meters correct to a cm. Specials shall be excluded and measured and paid separately under the relevant item. The portion of the pipe at the joints (inside the joints) shall not be included in the length of pipe work. Excavation, refilling, masonry and concrete work wherever required shall be measured and paid for separately under relevant items of work.

12. Rates

The rate shall include the cost of materials and labour involved in all the operations except for the items measured/enumerated separately under clause 'Measurements', which shall be paid for separately.

- 12 This USOR contains the rates of all the items without GST. No claims against GST shall be entertained at any level. GST shall be paid by the Agency/ Contractor directly to the concerning department. Howerer, All the estimates prepared on this USOR will include GST, as an extra amount as per prevailing rates on the sum of the estimate to arrive at the gross amount.**

BAR WRAPPED STEEL CYLINDER PIPES (BWSC)

| Sr.No. | Item | Unit | Rate (In Rs.) |
|--------|--|------|---------------|
| 11.1. | Providing Bar Wrapped Steel Cylinder Pipes test Presure 4 Kg/Sqcm including testing, inspection, trasportaion at site, transit insurance, loading unloading & stacking etc. complete. | | |
| | 350 mm | RM | 2400 |
| | 400 mm | RM | 2741 |
| | 450 mm | RM | 3172 |
| | 500 mm | RM | 3531 |
| | 600 mm | RM | 4700 |
| | 700 mm | RM | 5520 |
| | 800 mm | RM | 6308 |
| | 900 mm | RM | 7976 |
| | 1000 mm | RM | 9206 |
| | 1100 mm | RM | 13443 |
| | 1200 mm | RM | 14914 |
| | 1300 mm | RM | 16326 |
| | 1400 mm | RM | 18163 |
| | 1500 mm | RM | 21034 |
| | 1600 mm | RM | 22398 |

| Sr.No. | Item | Unit | Rate (In Rs.) |
|---------------|--|-------------|----------------------|
| 11.2. | Labour only for laying & jointing Bar Wrapped Steel Cylinder Pipe stest Presure 4 Kg/Sqcm including testing & cost of jointing materialas per relevant IS Specifications. | | |
| | 350 mm | RM | 488 |
| | 400 mm | RM | 561 |
| | 450 mm | RM | 642 |
| | 500 mm | RM | 765 |
| | 600 mm | RM | 864 |
| | 700 mm | RM | 1018 |
| | 800 mm | RM | 1166 |
| | 900 mm | RM | 1473 |
| | 1000 mm | RM | 1483 |
| | 1100 mm | RM | 2116 |
| | 1200 mm | RM | 2354 |
| | 1300 mm | RM | 2498 |
| | 1400 mm | RM | 2186 |
| | 1500 mm | RM | 2356 |
| | 1600 mm | RM | 2696 |
| 11.3 | Providing Bar Wrapped Steel Cylinder Pipes test Presure 6 Kg/Sqcm including testing, inspection, trasportaion at site, transit insurance, loading unloading & stacking etc. complete. | | |
| | 350 mm | RM | 2404 |
| | 400 mm | RM | 2745 |
| | 450 mm | RM | 2160 |
| | 500 mm | RM | 3539 |
| | 600 mm | RM | 4707 |
| | 700 mm | RM | 5535 |
| | 800 mm | RM | 6316 |
| | 900 mm | RM | 7984 |
| | 1000 mm | RM | 9219 |
| | 1100 mm | RM | 13451 |
| | 1200 mm | RM | 14926 |
| | 1300 mm | RM | 16335 |
| | 1400 mm | RM | 18175 |
| | 1500 mm | RM | 21051 |
| | 1600 mm | RM | 22418 |

| Sr.No. | Item | Unit | Rate (In Rs.) |
|---------------|---|-------------|----------------------|
| 11.4 | Labour only for laying & jointing Bar Wrapped Steel Cylinder Pipes test Presure 6 Kg/Sqcm including testing & cost of jointing material as per relevant IS specification. | | |
| | 350 mm | RM | 489 |
| | 400 mm | RM | 563 |
| | 450 mm | RM | 645 |
| | 500 mm | RM | 768 |
| | 600 mm | RM | 868 |
| | 700 mm | RM | 1021 |
| | 800 mm | RM | 1169 |
| | 900 mm | RM | 1475 |
| | 1000 mm | RM | 1488 |
| | 1100 mm | RM | 2117 |
| | 1200 mm | RM | 2356 |
| | 1300 mm | RM | 2500 |
| | 1400 mm | RM | 2187 |
| | 1500 mm | RM | 2358 |
| | 1600 mm | RM | 2698 |
| 11.5 | Providing Bar Wrapped Steel Cylinder Pipes test Presure 8 Kg/Sqcm including testing, inspection, trasportation at site, transit insurance, loading unloading & stacking etc. complete. | | |
| | 350 mm | RM | 2407 |
| | 400 mm | RM | 2753 |
| | 450 mm | RM | 3182 |
| | 500 mm | RM | 3550 |
| | 600 mm | RM | 4713 |
| | 700 mm | RM | 5553 |
| | 800 mm | RM | 6326 |
| | 900 mm | RM | 7989 |
| | 1000 mm | RM | 9232 |
| | 1100 mm | RM | 13463 |
| | 1200 mm | RM | 14944 |
| | 1300 mm | RM | 16344 |
| | 1400 mm | RM | 18191 |
| | 1500 mm | RM | 21069 |
| | 1600 mm | RM | 22433 |

| Sr.No. | Item | Unit | Rate (In Rs.) |
|---------------|--|-------------|----------------------|
| 11.6 | Labour only for laying & jointing Bar Wrapped Steel Cylinder Pipe test Pressure 8 Kg/Sqcm including testing & cost of jointing material as per relevant IS Specifications. | | |
| | 350 mm | RM | 489 |
| | 400 mm | RM | 567 |
| | 450 mm | RM | 649 |
| | 500 mm | RM | 772 |
| | 600 mm | RM | 873 |
| | 700 mm | RM | 1025 |
| | 800 mm | RM | 1172 |
| | 900 mm | RM | 1476 |
| | 1000 mm | RM | 1491 |
| | 1100 mm | RM | 2119 |
| | 1200 mm | RM | 2359 |
| | 1300 mm | RM | 2504 |
| | 1400 mm | RM | 2189 |
| | 1500 mm | RM | 2361 |
| | 1600 mm | RM | 2701 |
| 11.7 | Providing Bar Wrapped Steel Cylinder Pipes test Pressure 10 Kg/Sqcm including testing, inspection, transportation at site, transit insurance, loading unloading & stacking etc. complete. | | |
| | 350 mm | RM | 2408 |
| | 400 mm | RM | 2763 |
| | 450 mm | RM | 3189 |
| | 500 mm | RM | 3560 |
| | 600 mm | RM | 4722 |
| | 700 mm | RM | 5574 |
| | 800 mm | RM | 6339 |
| | 900 mm | RM | 7994 |
| | 1000 mm | RM | 9249 |
| | 1100 mm | RM | 13481 |
| | 1200 mm | RM | 14964 |
| | 1300 mm | RM | 16357 |
| | 1400 mm | RM | 18212 |
| | 1500 mm | RM | 21090 |
| | 1600 mm | RM | 22454 |

| Sr.No. | Item | Unit | Rate (In Rs.) |
|--------|--|------|---------------|
| 11.8 | Labour only for laying & jointing Bar Wrapped Steel Cylinder Pipe test Pressure 10 Kg/Sqcm including testing & cost of jointing material as per relevant IS Specification. | | |
| | 350 mm | RM | 490 |
| | 400 mm | RM | 571 |
| | 450 mm | RM | 653 |
| | 500 mm | RM | 777 |
| | 600 mm | RM | 877 |
| | 700 mm | RM | 1029 |
| | 800 mm | RM | 1177 |
| | 900 mm | RM | 1477 |
| | 1000 mm | RM | 1496 |
| | 1100 mm | RM | 2122 |
| | 1200 mm | RM | 2363 |
| | 1300 mm | RM | 2508 |
| | 1400 mm | RM | 2192 |
| | 1500 mm | RM | 2364 |
| | 1600 mm | RM | 2704 |
| 11.9 | Providing Bar Wrapped Steel Cylinder Pipes test Pressure 12 Kg/Sqcm including testing, inspection, transportation at site, transit insurance, loading unloading & stacking etc. complete. | | |
| | 350 mm | RM | 2411 |
| | 400 mm | RM | 2769 |
| | 450 mm | RM | 3194 |
| | 500 mm | RM | 3572 |
| | 600 mm | RM | 4734 |
| | 700 mm | RM | 5597 |
| | 800 mm | RM | 6632 |
| | 900 mm | RM | 8001 |
| | 1000 mm | RM | 9635 |
| | 1100 mm | RM | 13501 |
| | 1200 mm | RM | 14985 |
| | 1300 mm | RM | 16373 |
| | 1400 mm | RM | 18237 |
| | 1500 mm | RM | 21328 |
| | 1600 mm | RM | 22465 |

| Sr.No. | Item | Unit | Rate (In Rs.) |
|--------|--|------|---------------|
| 11.10 | Labour only for laying & jointing Bar Wrapped Steel Cylinder Pipe test Pressure 12 Kg/Sqcm including testing & cost of jointing material as per relevant IS Specification. | | |
| | 350 mm | RM | 490 |
| | 400 mm | RM | 578 |
| | 450 mm | RM | 658 |
| | 500 mm | RM | 782 |
| | 600 mm | RM | 883 |
| | 700 mm | RM | 1034 |
| | 800 mm | RM | 1238 |
| | 900 mm | RM | 1479 |
| | 1000 mm | RM | 1568 |
| | 1100 mm | RM | 2126 |
| | 1200 mm | RM | 2367 |
| | 1300 mm | RM | 2512 |
| | 1400 mm | RM | 2196 |
| | 1500 mm | RM | 2551 |
| | 1600 mm | RM | 2830 |
| 11.11 | Providing Bar Wrapped Steel Cylinder Pipes test Pressure 14 Kg/Sqcm including testing, inspection, transportation at site, transit insurance, loading unloading & stacking etc. complete. | | |
| | 350 mm | RM | 2413 |
| | 400 mm | RM | 2779 |
| | 450 mm | RM | 3204 |
| | 500 mm | RM | 3636 |
| | 600 mm | RM | 4824 |
| | 700 mm | RM | 6008 |
| | 800 mm | RM | 7256 |
| | 900 mm | RM | 8777 |
| | 1000 mm | RM | 11059 |
| | 1100 mm | RM | 13551 |
| | 1200 mm | RM | 15153 |
| | 1300 mm | RM | 17174 |
| | 1400 mm | RM | 19708 |
| | 1500 mm | RM | 24598 |
| | 1600 mm | RM | 25892 |

| Sr.No. | Item | Unit | Rate (In Rs.) |
|--------|--|------|---------------|
| 11.12 | Labour only for laying & jointing Bar Wrapped Steel Cylinder Pipe test Pressure 14 Kg/Sqcm including testing & cost of jointing material as per relevant IS Specification. | | |
| | 350 mm | RM | 491 |
| | 400 mm | RM | 582 |
| | 450 mm | RM | 674 |
| | 500 mm | RM | 791 |
| | 600 mm | RM | 892 |
| | 700 mm | RM | 1128 |
| | 800 mm | RM | 1445 |
| | 900 mm | RM | 1613 |
| | 1000 mm | RM | 1752 |
| | 1100 mm | RM | 2135 |
| | 1200 mm | RM | 2401 |
| | 1300 mm | RM | 2659 |
| | 1400 mm | RM | 2416 |
| | 1500 mm | RM | 2716 |
| | 1600 mm | RM | 3377 |
| 11.13 | Providing Bar Wrapped Steel Cylinder Pipes test Pressure 16 Kg/Sqcm including testing, inspection, transportation at site, transit insurance, loading unloading & stacking etc. complete. | | |
| | 350 mm | RM | 2417 |
| | 400 mm | RM | 2791 |
| | 450 mm | RM | 3226 |
| | 500 mm | RM | 3833 |
| | 600 mm | RM | 5088 |
| | 700 mm | RM | 6374 |
| | 800 mm | RM | 7243 |
| | 900 mm | RM | 9366 |
| | 1000 mm | RM | 11323 |
| | 1100 mm | RM | 13993 |
| | 1200 mm | RM | 16164 |
| | 1300 mm | RM | 18491 |
| | 1400 mm | RM | 21199 |
| | 1500 mm | RM | 25225 |
| | 1600 mm | RM | 27734 |

| Sr.No. | Item | Unit | Rate (In Rs.) |
|--------|--|------|---------------|
| 11.14 | Labour only for laying & jointing Bar Wrapped Steel Cylinder Pipe test Pressure 16 Kg/Sqcm including testing & cost of jointing material as per relevant IS Specification. | | |
| | 350 mm | RM | 492 |
| | 400 mm | RM | 587 |
| | 450 mm | RM | 700 |
| | 500 mm | RM | 858 |
| | 600 mm | RM | 971 |
| | 700 mm | RM | 1237 |
| | 800 mm | RM | 1517 |
| | 900 mm | RM | 1743 |
| | 1000 mm | RM | 1771 |
| | 1100 mm | RM | 2284 |
| | 1200 mm | RM | 2670 |
| | 1300 mm | RM | 2903 |
| | 1400 mm | RM | 2698 |
| | 1500 mm | RM | 3046 |
| | 1600 mm | RM | 3462 |
| 11.15 | Providing Bar Wrapped Steel Cylinder Pipes test Pressure 18 Kg/Sqcm including testing, inspection, transportation at site, transit insurance, loading unloading & stacking etc. complete. | | |
| | 350 mm | RM | 2421 |
| | 400 mm | RM | 2799 |
| | 450 mm | RM | 3382 |
| | 500 mm | RM | 4025 |
| | 600 mm | RM | 5371 |
| | 700 mm | RM | 6742 |
| | 800 mm | RM | 7724 |
| | 900 mm | RM | 9953 |
| | 1000 mm | RM | 12141 |
| | 1100 mm | RM | 14860 |
| | 1200 mm | RM | 17217 |
| | 1300 mm | RM | 19671 |
| | 1400 mm | RM | 22777 |
| | 1500 mm | RM | 26940 |
| | 1600 mm | RM | 30097 |

| Sr.No. | Item | Unit | Rate (In Rs.) |
|--------|--|------|---------------|
| 11.16 | Labour only for laying & jointing Bar Wrapped Steel Cylinder Pipe test Pressure 18 Kg/Sqcm including testing & cost of jointing material as per relevant IS Specification. | | |
| | 350 mm | RM | 493 |
| | 400 mm | RM | 594 |
| | 450 mm | RM | 714 |
| | 500 mm | RM | 889 |
| | 600 mm | RM | 1015 |
| | 700 mm | RM | 1292 |
| | 800 mm | RM | 1635 |
| | 900 mm | RM | 1829 |
| | 1000 mm | RM | 1872 |
| | 1100 mm | RM | 2394 |
| | 1200 mm | RM | 2805 |
| | 1300 mm | RM | 3122 |
| | 1400 mm | RM | 2855 |
| | 1500 mm | RM | 3199 |
| | 1600 mm | RM | 3771 |
| 11.17 | Providing Bar Wrapped Steel Cylinder Pipes test Pressure 20 Kg/Sqcm including testing, inspection, transportation at site, transit insurance, loading unloading & stacking etc. complete. | | |
| | 350 mm | RM | 2503 |
| | 400 mm | RM | 2961 |
| | 450 mm | RM | 3579 |
| | 500 mm | RM | 4293 |
| | 600 mm | RM | 5725 |
| | 700 mm | RM | 7233 |
| | 800 mm | RM | 9041 |
| | 900 mm | RM | 10803 |
| | 1000 mm | RM | 13444 |
| | 1100 mm | RM | 16101 |
| | 1200 mm | RM | 18678 |
| | 1300 mm | RM | 21402 |
| | 1400 mm | RM | 25027 |
| | 1500 mm | RM | 30086 |
| | 1600 mm | RM | 33247 |

| Sr.No. | Item | Unit | Rate (In Rs.) |
|--------|--|------|---------------|
| 11.18 | Labour only for laying & jointing Bar WrappedSteelCylinderPipestestPresure 20 Kg/Sqcm including testing & cost of jointing material as per relevant IS Specification. | | |
| | 350 mm | RM | 498 |
| | 400 mm | RM | 605 |
| | 450 mm | RM | 746 |
| | 500 mm | RM | 956 |
| | 600 mm | RM | 1093 |
| | 700 mm | RM | 1401 |
| | 800 mm | RM | 1766 |
| | 900 mm | RM | 2011 |
| | 1000 mm | RM | 2052 |
| | 1100 mm | RM | 2637 |
| | 1200 mm | RM | 3082 |
| | 1300 mm | RM | 3438 |
| | 1400 mm | RM | 3104 |
| | 1500 mm | RM | 3494 |
| | 1600 mm | RM | 4048 |

CHAPTER –XII

STONE WARE PIPES FOR SEWERS

CHAPTER - XII
STONE WARE PIPES FOR SEWERS
(Pipes conforming to IS: 651-1992)

Notes :

The salt Glazed stoneware pipe shall be confirming to IS:651 :1992.

The laying to S.W. pipes shall be done as per IS - 4127 :1983

The bedding of the S.W. pipes shall be as per the specification given in the CPHEEO manual of sewerage & sewage treatment, payment for which shall be made as per chapter XII allied civilworks.

The testing of the sewer line& refilling shall be done as per CPHEEO manual on sewerage and sewagemanagement.

In order to avoid damage to the pipes and especially to the spigot end, pipes shall not be dragged along concrete and similar pavements with hard surfaces.

The pipes and fittings shall be inspected for defects and be rung with a light hammer preferable while suspended to detectcracks.

All lumps, blisters and excess coating materials shall be removed gently from the socket and spigot of each pipe. The out side of the spigot and the insideofthesocketshallbewipedcleananddrybeforethepipeislaidd.

In shallow trenches, manual handing is enough but in deep trenches, they shall be lowered in to the trench by mean of ropes. Under no circumstances the pipe shall be dropped or dumped into thetrench.

Every precaution shall be taken to prevent foreign material from entering the pipe when it is being placed in the line.

The pipe between two manholes shall be laid truly in a straight line without vertical and horizontal undulations. The pipe shall be laid true to line and grade as specified in the relevant specifications.

2 Unloading of pipes:

While unloading, pipes shall not be thrown from the truck on hardground.

3. Trenches:

The width of trench at and below the top of sewer should be the minimum necessary for its proper installation with the due consideration to its bedding. It should be as per clause 7.1.1 page 126 of construction of sewers as per CPHEEO manual on sewerage and sewage treatment (second edition).

Unloading of pipes on timber skids without a steadying rope and thus allowing the pipes to bump hard against one another should not be allowed.

Where the sewer has to be laid in a soft under ground strata or in a reclaimed land, the trench shall be excavated deeper than what is ordinary required. The trench bottom shall be stabilised by the addition of coarse gravel or rock, in case of very bed soil the trench bottom shall be filled in with cement concrete. For class of bedding details clause 6.5.3.1 page 116 of CPHEEO manual on sewerage and sewage treatment should be followed.

In order to avoid damage to the pipes and especially to the spigot end, pipes should not be dragged along concrete and similar pavements with hard surfaces.

The pipe and fittings shall be inspected for defects and be rung with a light hammer preferably while suspended, to detect cracks.

All lumps, blisters and excess coating materials shall be removed gently from the socket and spigot end of each pipe and the outside of the spigot and the inside of the socket shall be wiped clean and dry before the pipe is laid.

In shallow trenches manual handling is enough but in deep trenches, they should be lowered into the trench by means of ropes. Under no circumstances shall not the pipes be dropped or dumped into the trench.

Every precaution shall be taken to prevent foreign materials from entering the pipe when it is being placed in the line.

The pipes between two main holes shall be laid truly in a straight line without vertical and horizontal undulations. The pipes shall be laid true to line and grade as specified.

Sight rails provided at all changes of direction or gradient and at distances of about 15 meters along straight lengths, with centre line marked each horizontal rail, which is fixed at true level, shall be used for laying all inverts.

Normally the socket ends should face the up stream. When the line runs up hill the socket ends should face the up grade.

The stone ware pipes shall be laid with sockets facing up the gradient, on desired, special bedding. Hunching or encasing may be provided where conditions so demand as discussed in clause 6.5 of CPHEEO manual on sewerage and sewage treatment.

Where pipes are not bedded on concrete, the trench floor shall be left slightly high and carefully buttoned up as pipe laying proceeds, so that the pipes barrels rest on firm and undisturbed ground. If the excavation has been carried too low the desired levels shall be made up with concrete 1:5:10 (1 cement: 5 fine cement: 10 graded stone aggregate 40 mm nominal size) for which no extra payment shall be made. The pipe shall be secured in place with approved back fill material or concrete tamped under it except at the socket.

Pipe and fittings, which do not allow a sufficient and uniform space for joints, shall be removed and replaced with pipe and fittings of proper dimensions to ensure such uniform space.

At times when pipe laying is not in progress, the open ends of pipe shall be closed by a water tight plug or canvas or other means approved by the Engineer incharge.

Trenches shall be kept free from water until the material in the joints has hardens.

When the pipe is closed and the trench to be flooded by rain; care shall be taken to prevent the pipe from floating.

The cutting of pipe for inserting, fittings or closure pieces shall be done in a neat and work manlike manner without damage to the pipe or inside coating so as to leave a smooth surface and at right angle to the axis of the pipe.

The Engineer In-charge should consult the appropriate authorities before preparing plans and specifications for pipeline crossing Railway lines, Irrigation channels or similar works.

The connection to an existing sewer shall be done through manholes.

Before connecting a pipe to a manhole, a relieving arch or any other similar protection device should be made in the manhole for the safety of the pipe.

The pipes when laid, should not be subjected to superimposed load beyond their safe crushing strength.

4. Jointing:

The stoneware pipes shall be cement jointed.

The materials shall consist of the following.

(a) Spun yarn or tarred gaskets.

(b) Cement.

(c) Sand

4.3. In each joint, spun yarn soaked in neat cement slurry or tarred gasket shall be passed round the joint and inserted in it by means of a caulking tool.

More yarn or gasket shall be added if necessary and shall be well caulked. Yarn or gasket so rammed shall not occupy more than one fourth of the depth of socket.

Cement mortar (1:1) (one part of cement to one part of sand) shall be slightly moistened and carefully inserted by hand into the remaining space of the joint after caulking of yarn or gasket. The mortar shall then be caulked into the joint with a caulking tool. More cement mortar shall be added until the joint space has been completely filled with tightly caulked mortar. The joint shall then be finished off neatly outside the socket at an angle of 45 degrees (IS4127-1983)

The cement mortar joints shall be cured at least for seven days before testing.

The joint with cast iron or concrete pipes shall be made with cement joints.

5. Testing:

Each section of sewer shall be tested for water tightness preferably between manholes.

Before commencing the hydraulic test the pipelines shall be filled with water for about a week before commencing the application of pressure to allow for the absorption by pipewall.

The sewers are tested by plugging the upper end with a provision for an air out let pipe with stopcock. The water is filled through a funnel connected at the lower end provided with a plug. After the air has expelled through the air out let, the stop cock is closed and water level in the funnel is noted after 30 minutes and gravity of water required to restore the original water level is determined. The pipe line under pressure is then inspected while the funnel is still in position. There shall be no any leaks in the pipe or joints (small sweating on the pipe surface is permitted).

Any sewer or part there of that does not meet the test shall be emptied and repaired or re-laid as required and tested again.

The leakage of quantity of water to be supplied to maintain the test pressure during the period of 10 minutes shall not exceed 0.2 litres/mm dia. of pipe per kilometre length per day.

It should be done as per clause 7.1.5 page 131 of CPHEEO manual on sewerage and sewage treatment.

6. **Refilling:**

No trench shall be filled in unless the sewer stretches have been tested and approved for water tightness of joints. However partial filling may be done keeping the joints open to avoid disturbance. Soft material screened free from stones or hard substances shall first be used and hand pressured under and around the pipes to half their height. Similarly soft material shall be put up to a height of 30cm above top of pipe and then this will be moistened with water and well rammed. The reminder of the trench can be filled with hard material, in stages, each not exceeding 60 cm. At each stage the filling shall be well rammed, consolidated and completely saturated with water and then only further filling shall be continued. It should be done as per procedure given in clause 7.1.9 page 133 of CPHEEO manual on sewerage and sewage treatment.

7. **Measurements:**

The lengths of pipe shall be measured in the running meters nearest to a cm as laid or fixed, from inside of one manhole to the inside of the other manhole the length shall be taken. Along the centre line of the pipes overall fittings. Such as bends, junction, etc., which shall not be measured separately. Excavation refilling shoring and timbering in trenches and cement concreting where ever required shall be measured separately under relevant item of work.

8. **Rate:**

The rate shall include the cost of material and labour involved in all the operation described above including the cost of concrete which shall be paid separately.

9. **This USOR contains the rates of all the items without GST. No claims against GST shall be entertained at any level. GST shall be paid by the Agency/ Contractor directly to the concerning department. Howerer, All the estimates prepared on this USOR will include GST, as an extra amount as per prevailing rates on the sum of the estimate to arrive at the gross amount.**

STONE WARE PIPES FOR SEWERS
(Pipes conforming to IS: 651-1992)

| S. No. | Items | Unit | Rates in Rs. |
|--------|---|----------|--------------|
| 12.1 | Providing and Laying and Jointing salt glazed stone ware (S.W.) pipes socket and spigot with stiff cement mortar 1:1 including testing of joints complete | | |
| | 100mm | R. Meter | 256 |
| | 150 mm | R. Meter | 370 |
| | 200 mm | R. Meter | 598 |
| | 250 mm | R. Meter | 958 |
| | 300 mm | R. Meter | 1271 |
| 12.2 | Labour only for Laying and Jointing salt glazed stone ware (S.W.) pipes s&s (socket and spigot) with stiff cement mortar 1:1 including testing of joints complete. | | |
| | 100mm | R. Meter | 82 |
| | 150 mm | R. Meter | 119 |
| | 200 mm | R. Meter | 141 |
| | 250 mm | R. Meter | 185 |
| | 300 mm | R. Meter | 210 |
| 12.3 | Providing and laying cement concrete 1:5:10 (1 cement:5 fine sand: 10 graded stone aggregate 40 mm nominal size) around S.W. pipe including bed concrete 15 cm thick i/c curing, testing etc. complete for 100mm dia. to 300mm dia pipe. (For type "Concrete Around") | | |
| | 100mm dia SW pipe | R. Meter | 523 |
| | 150mm dia | R. Meter | 639 |
| | 200mm dia | R. Meter | 745 |
| | 250mm dia | R. Meter | 815 |
| | 300mm dia | R. Meter | 988 |
| 12.4 | Providing and laying cement concrete 1:5:10 (1 cement:5 fine sand: 10 graded stone aggregate 40 mm nominal size) up to haunches of SW – pipes including bed concrete i/c curing, testing etc complete for 100mm to 300mm dia SW pipe For Type "Concrete up to Haunches ") | | |

| S. No. | Items | Unit | Rates in Rs. |
|---------------|---|-------------|---------------------|
| | 100mm dia pipe | R. Meter | 248 |
| | 150mm dia | R. Meter | 401 |
| | 200mm dia | R. Meter | 473 |
| | 250mm dia | R. Meter | 551 |
| | 300mm dia | R. Meter | 635 |
| 12.5 | Dismantling of old S.W. pipes including breaking of joints and bed concrete stacking of useful materials near the site within 50 m lead and disposal of unserviceable materials in to municipal dumps : | | |
| | 100mm dia pipe | R. Meter | 27 |
| | 150mm dia | R. Meter | 31 |
| | 200mm dia | R. Meter | 33 |
| | 250mm dia | R. Meter | 35 |
| | 300mm dia | R. Meter | 37 |

CHAPTER- XIII

REINFORCED CEMENT CONCRETE PIPES

CHAPTER- XIII
REINFORCED CEMENT CONCRETE PIPES
(PIPES CONFORMING TO IS: 458-1988)

NOTES :

All the pipes, specials, joints to be used in the work shall conform to relevant Indian Standards duly inspected and tested and having B.I.S. certificationmark.

1. Laying:

Reasonable care shall be exercised in loading, transporting and unloading concrete pipes. Handling shall be such as to avoid impact. Gradual unloading by inclined plane or by chain block is recommended.

Pipes shall be lowered in to the trench carefully by mechanical appliances. Under no circumstances shall the pipes be dropped or dumped in to the trench.

All pipe sections and connections shall be inspected carefully before being laid. Broken or defective pipes or connections shall not be used.

All lumps, blisters and excess coating materials shall be removed gently from the ends of each pipe and they should be wiped clean and dry before the pipe is laid.

In the case of pipes with joints to be made with loose collars, the collars shall be slipped on before the next pipe is laid.

Every precaution shall be taken to prevent foreign materials from entering the pipe when it is being placed in the line

Pipes shall be laid in true line and grade, as specified.

Sight rails provided at all change of directions or gradients and at distances of about 15 meters along. Straight lengths with centre line marked on each horizontal rail which is fixed at true level, shall be used for laying all inverts with the help of proper boning rods.

Laying of pipes shall always proceed up grade of a slope. If the pipes have spigot and socket joints, the socket ends shall face upstream. In the cases of pipes with joints to be made with loose collars, the collars shall be slipped on before the next pipe is laid.

The pipe shall be secured in place with approved back fill material or concrete tamped under it except at the joint portion.

Precautions shall be taken to prevent dirt from entering the joint space.

When pipe laying is not in progress, the open ends of pipe shall be closed by a water tight plug or canvas or other means approved by the Engineer in charge.

Trench shall be kept free from water until the material in the joints has hardened.

When the pipe is closed and the trench liable to be flooded by rain, care shall be taken to prevent the pipe from floating.

Walking or working on the completed pipe shall not be permitted until the trench has been back filled to a height of at least 30 CM over the pipe, except as may be necessary in tamping or backfilling.

The cutting of pipe for inserting, fittings or closure pieces shall be done in a neat and workmanlike manner without danger to the pipe so as to leave a smooth surface and at right angles to the axis of the pipe.

The Engineer-in-Charge should consult the appropriate authorities before preparing plans and specifications for pipe line crossing railway lines, Irrigation, channels or similar other works and services.

The connection to an existing sewer shall be done through manholes.

Before connecting a pipe to a manhole, a relieving arch or any other similar protection device should be made in the manhole for the safety of the pipe.

The pipe when laid should not be subjected to super imposed load beyond what the pipe can safely take up.

2. Pipe Bedding:

In case where the foundation conditions are unsafe such as in the proximity of trees or poles, under existing or proposed tracks, under manholes etc; the pipe shall be encased, in low strength concrete bedding or compacted sand or gravel.

The following class of pipe beddings are recommended as per CPHEEO manual. The class of bedding depends upon the site condition and loading.

| | |
|------------------|--|
| Class-A bedding | It may either concrete cradle or concrete arch depend upon the design. |
| Class-B bedding- | It is having a shaped bottom or compacted granular bedding with a carefully compacted back fill. |

Class-C bedding- It is ordinary bedding having a compacted granular bedding with a lightly compacted back fill.

The pipe bedding materials must remain firm and not permit displacement of pipes. Where rock or other unyielding foundation material is encountered, bedding shall be according to one of the classes A, B or C but with the following additional requirements.

Class-A bedding-The hard unyielding material should be excavated down to the bottom of the concrete cradle.

Class-B or C bedding: The hard unyielding material should be excavated below the bottom of the pipe and pipe bell to depth of at least 15cm. The width of trench should be at least 1.25 times the outside dia of pipe and it should be refilled with granular material.

When the pipe is laid in a trench in rock, hard clay, shale or other hard material, the space below the pipe shall be excavated and replaced with an equalising bed of concrete, sand or compacted earth. In no place the pipe shall be laid directly on such hard material.

The bedding shall be as per details given in chapter VI 'Structural design of buried sewer' given in CPHEEO manual on sewerage and sewage treatment (1993 second edition).

3. Jointing:

- (a) The socket and spigot pipes are laid and jointed with rubber gasket.
- (b) In case of collar jointed pipe, the jointing shall be done with hemp yarn soaked in cement slurry tamped with just sufficient quantity of water to have a consistency of semi dry condition, well packed and thoroughly rammed with caulking tools and then filled with cement mortar 1:2. The joint shall be finished off with a fillet slopping at 45 degrees to the surface of the pipe. The finished joint shall be protected and cured for at least 24 hours. For jointing, procedure shall be followed as per I.S. 783 –1985.

4. Testing:

Each section of sewer shall be tested for water tightness preferably between manholes. In case of cement mortar joints, the sewer line shall be tested three days after the cement mortar joints have been made. The pipe line shall be filled with water for about a week before commencing the application of pressure to allow for the absorption by pipe wall. The pipe line shall be tested by plugging the upper end with a provision for an air outlet pipe with stop cock. The water shall be filled through a funnel connected at the lower end provided with a plug. After expelling the air

through the air outlet, the stop cock shall be closed and water level in the funnel shall be raised to 2.5 m above the inlet at the upper end. Water level in the funnel is noted after 30 minutes and the quantity of water required to restore the original water level in the funnel is determined. The pipe line under pressure is then inspected while funnel is still in position. There shall not be any leaks in the pipe or joints (small sweating on the pipe surface is permitted).

Any sewer or part thereof that doesn't meet the test shall be emptied and repaired or re-laid as required and tested again. The leakage or quantity of water to be supplied to maintain the test pressure during the period of 10 minutes should not exceed 0.2 liters/mm diameter of pipe per Km. length per day. For non pressure pipes the leakage should be observed for a period of 24 hours. Exfiltration test for detection of leakage shall be carried out at a time when the ground water table is low. Air testing shall be done particularly in large diameter pipes when the required quantity of water is not available for testing subjected to the provisions made in the agreement. It is done as per procedure given in CPHEEO manual (1993 second edition).

5. Back filling of trenches:

The method of backfilling to be used shall vary with the width of trench, the character of material excavated, the method of excavation and degree of compaction required.

- (1) In open country, it shall be sufficient to mound the trench and after natural settlement return to regrade the areas.
- (2) In developed streets, it shall be compacted to minimize the load.
- (3) Soft material screened free from stones or hard substances shall first be used and hand pressed under and around the pipes to half the height. Similar soft material shall then be put up to a height of 30 cm. above the top of pipe and this will be moistened with water and well rammed. The remaining trench can be filled with hard material, in layers each not exceeding 60 cm. At each stage the filling shall be well rammed, consolidated and completely saturated with water and then only further filling shall be continued.

- 10. This USOR contains the rates of all the items without GST. No claims against GST shall be entertained at any level. GST shall be paid by the Agency/ Contractor directly to the concerning department. However, All the estimates prepared on this USOR will include GST, as an extra amount as per prevailing rates on the sum of the estimate to arrive at the gross amount.**

CHAPTER XIII
REINFORCED CEMENT CONCRETE PIPES
(PIPES CONFORMING TO IS: 458-1988)

| Sr.No. | Item | Unit | Rate (In Rs.) |
|-------------|---|-----------|---------------|
| 13.1 | Providing and Laying non-pressure (NP2) RCC socket & spigot pipes with rubber gasket joint including testing of joints. | | |
| | 100 mm Dia | Per Meter | 425 |
| | 150 mm Dia | Per Meter | 443 |
| | 200 mm Dia | Per Meter | 517 |
| | 250 mm Dia | Per Meter | 627 |
| | 300 mm Dia | Per Meter | 857 |
| | 350 mm Dia | Per Meter | 981 |
| | 400 mm Dia | Per Meter | 1146 |
| | 450 mm Dia | Per Meter | 1384 |
| | 500 mm Dia | Per Meter | 1506 |
| | 600 mm Dia | Per Meter | 1899 |
| | 700 mm Dia | Per Meter | 2490 |
| | 800 mm Dia | Per Meter | 3255 |
| | 900 mm Dia | Per Meter | 3813 |
| | 1000 mm Dia | Per Meter | 4414 |
| | 1100 mm Dia | Per Meter | 5298 |
| 1200 mm Dia | Per Meter | 6603 | |
| 1600 mm Dia | Per Meter | 10595 | |
| 13.2 | Labour only for Laying and Jointing non-pressure (NP2) RCC socket & spigot pipes with rubber gasket joint including testing of joints. | | |
| | 100 mm Dia | Per Meter | 77 |
| | 150 mm Dia | Per Meter | 122 |
| | 200 mm Dia | Per Meter | 141 |
| | 250 mm Dia | Per Meter | 183 |
| | 300 mm Dia | Per Meter | 227 |
| | 350 mm Dia | Per Meter | 230 |
| | 400 mm Dia | Per Meter | 262 |
| | 450 mm Dia | Per Meter | 301 |
| | 500 mm Dia | Per Meter | 335 |
| | 600 mm Dia | Per Meter | 406 |
| | 700 mm Dia | Per Meter | 455 |
| | 800 mm Dia | Per Meter | 543 |
| | 900 mm Dia | Per Meter | 653 |
| | 1000 mm Dia | Per Meter | 715 |
| | 1100 mm Dia | Per Meter | 788 |
| 1200 mm Dia | Per Meter | 905 | |
| 1600 mm Dia | Per Meter | 1307 | |
| 13.3 | Providing and Laying non-pressure (NP3) RCC socket & spigot pipes with rubber gasket joint including testing of joints. | | |

| Sr.No. | Item | Unit | Rate (In Rs.) |
|---------------|---|-------------|----------------------|
| | 150 mm Dia | Per Meter | 578 |
| | 250 mm Dia | Per Meter | 903 |
| | 300 mm Dia | Per Meter | 1128 |
| | 350 mm Dia | Per Meter | 1527 |
| | 400 mm Dia | Per Meter | 1959 |
| | 450 mm Dia | Per Meter | 2165 |
| | 500 mm Dia | Per Meter | 2451 |
| | 600 mm Dia | Per Meter | 2950 |
| | 700 mm Dia | Per Meter | 3895 |
| | 800 mm Dia | Per Meter | 4930 |
| | 900 mm Dia | Per Meter | 5849 |
| | 1000 mm Dia | Per Meter | 6674 |
| | 1100 mm Dia | Per Meter | 7623 |
| | 1200 mm Dia | Per Meter | 8381 |
| | 1400 mm Dia | Per Meter | 10493 |
| | 1600 mm Dia | Per Meter | 12372 |
| | 1800 mm Dia | Per Meter | 15829 |
| 13.4 | Labour only for laying and Jointing non-pressure (NP3) RCC socket & spigot pipes with rubber gasket joint including testing of joints. | | |
| | 150 mm Dia | Per Meter | 122 |
| | 250 mm Dia | Per Meter | 168 |
| | 300 mm Dia | Per Meter | 233 |
| | 350 mm Dia | Per Meter | 361 |
| | 400 mm Dia | Per Meter | 396 |
| | 450 mm Dia | Per Meter | 451 |
| | 500 mm Dia | Per Meter | 485 |
| | 600 mm Dia | Per Meter | 601 |
| | 700 mm Dia | Per Meter | 664 |
| | 800 mm Dia | Per Meter | 810 |
| | 900 mm Dia | Per Meter | 1002 |
| | 1000 mm Dia | Per Meter | 1115 |
| | 1100 mm Dia | Per Meter | 1159 |
| | 1200 mm Dia | Per Meter | 1254 |
| | 1400 mm Dia | Per Meter | 1626 |
| | 1600 mm Dia | Per Meter | 1931 |
| | 1800 mm Dia | Per Meter | 2265 |
| 13.5 | Providing and Laying non-pressure (NP4) RCC socket & spigot pipes with rubber gasket joint including testing of joints. | | |
| | 250 mm Dia | Per Meter | 1009 |
| | 300 mm Dia | Per Meter | 1434 |
| | 350 mm Dia | Per Meter | 2013 |
| | 400 mm Dia | Per Meter | 2340 |
| | 450 mm Dia | Per Meter | 2808 |
| | 500 mm Dia | Per Meter | 3176 |
| | 600 mm Dia | Per Meter | 3687 |
| | 700 mm Dia | Per Meter | 4540 |
| | 800 mm Dia | Per Meter | 5751 |

| Sr.No. | Item | Unit | Rate (In Rs.) |
|---------------|--|-------------|----------------------|
| | 900 mm Dia | Per Meter | 6733 |
| | 1000 mm Dia | Per Meter | 7626 |
| | 1100 mm Dia | Per Meter | 8383 |
| | 1200 mm Dia | Per Meter | 9322 |
| | 1400 mm Dia | Per Meter | 11931 |
| | 1600 mm Dia | Per Meter | 14441 |
| | 1800 mm Dia | Per Meter | 18539 |
| 13.6 | Labour only for laying and jointing non-pressure (NP4) RCC socket & spigot pipes with rubber gasket joint including testing of joints. | | |
| | 250 mm Dia | Per Meter | 194 |
| | 300 mm Dia | Per Meter | 253 |
| | 350 mm Dia | Per Meter | 368 |
| | 400 mm Dia | Per Meter | 416 |
| | 450 mm Dia | Per Meter | 459 |
| | 500 mm Dia | Per Meter | 506 |
| | 600 mm Dia | Per Meter | 608 |
| | 700 mm Dia | Per Meter | 685 |
| | 800 mm Dia | Per Meter | 839 |
| | 900 mm Dia | Per Meter | 1023 |
| | 1000 mm Dia | Per Meter | 1140 |
| | 1100 mm Dia | Per Meter | 1189 |
| | 1200 mm Dia | Per Meter | 1338 |
| | 1400 mm Dia | Per Meter | 1714 |
| | 1600 mm Dia | Per Meter | 1931 |
| | 1800 mm Dia | Per Meter | 2265 |
| 13.7 | Providing, Laying & jointing non-pressure (NP2) RCC pipes with collars jointed with stiff mixture of cement mortar in the proportion 1:2 (1 cement : 2 sand) including testing of joints. | | |
| | 150 mm Dia | Per Meter | 274 |
| | 200 mm Dia | Per Meter | 399 |
| | 250 mm Dia | Per Meter | 425 |
| | 300 mm Dia | Per Meter | 500 |
| | 350 mm Dia | Per Meter | 621 |
| | 400 mm Dia | Per Meter | 721 |
| | 450 mm Dia | Per Meter | 863 |
| | 500 mm Dia | Per Meter | 894 |
| | 600 mm Dia | Per Meter | 990 |
| | 700 mm Dia | Per Meter | 1560 |
| | 800 mm Dia | Per Meter | 2075 |
| | 900 mm Dia | Per Meter | 2673 |
| | 1000 mm Dia | Per Meter | 3232 |
| | 1100 mm Dia | Per Meter | 3733 |
| | 1200 mm Dia | Per Meter | 4548 |
| 13.8 | Labour only for laying & jointing non-pressure (NP2) RCC pipes with collars jointed | | |

| Sr.No. | Item | Unit | Rate (In Rs.) |
|--------|---|-----------|---------------|
| | with stiff mixture of cement mortar in the proportion 1:2 (1 cement : 2 sand) including testing of joints. | | |
| | 150 mm Dia | Per Meter | 66 |
| | 200 mm Dia | Per Meter | 87 |
| | 250 mm Dia | Per Meter | 110 |
| | 300 mm Dia | Per Meter | 117 |
| | 350 mm Dia | Per Meter | 130 |
| | 400 mm Dia | Per Meter | 136 |
| | 450 mm Dia | Per Meter | 149 |
| | 500 mm Dia | Per Meter | 159 |
| | 600 mm Dia | Per Meter | 189 |
| | 700 mm Dia | Per Meter | 208 |
| | 800 mm Dia | Per Meter | 224 |
| | 900 mm Dia | Per Meter | 282 |
| | 1000 mm Dia | Per Meter | 357 |
| | 1100 mm Dia | Per Meter | 432 |
| | 1200 mm Dia | Per Meter | 532 |
| 13.9 | Providing, Laying & jointing non-pressure (NP3) RCC pipes with collars jointed with stiff mixture of cement mortar in the proportion 1:2 (1 cement : 2 sand)including testing of joints | | |
| | 150 mm Dia | Per Meter | 350 |
| | 200 mm Dia | Per Meter | 519 |
| | 250 mm Dia | Per Meter | 573 |
| | 300 mm Dia | Per Meter | 667 |
| | 350 mm Dia | Per Meter | 998 |
| | 400 mm Dia | Per Meter | 1399 |
| | 450 mm Dia | Per Meter | 1499 |
| | 500 mm Dia | Per Meter | 1679 |
| | 600 mm Dia | Per Meter | 1947 |
| | 700 mm Dia | Per Meter | 3025 |
| | 800 mm Dia | Per Meter | 3193 |
| | 900 mm Dia | Per Meter | 3735 |
| | 1000 mm Dia | Per Meter | 4485 |
| | 1100 mm Dia | Per Meter | 5316 |
| | 1200 mm Dia | Per Meter | 5620 |
| 13.10 | Labour only for laying & jointing non-pressure (NP3) RCC pipes with collars jointed with stiff mixture of cement mortar in the proportion 1:2 (1 cement : 2 sand) includingtesting of joints. | | |
| | 150 mm Dia | Per Meter | 69 |
| | 200 mm Dia | Per Meter | 92 |
| | 250 mm Dia | Per Meter | 114 |
| | 300 mm Dia | Per Meter | 122 |
| | 350 mm Dia | Per Meter | 136 |
| | 400 mm Dia | Per Meter | 141 |

| Sr.No. | Item | Unit | Rate (In Rs.) |
|---------------|---|-------------|----------------------|
| | 450 mm Dia | Per Meter | 156 |
| | 500 mm Dia | Per Meter | 165 |
| | 600 mm Dia | Per Meter | 196 |
| | 700 mm Dia | Per Meter | 217 |
| | 800 mm Dia | Per Meter | 233 |
| | 900 mm Dia | Per Meter | 293 |
| | 1000 mm Dia | Per Meter | 370 |
| | 1100 mm Dia | Per Meter | 449 |
| | 1200 mm Dia | Per Meter | 553 |
| 13.11 | Providing, Laying & jointing non-pressure (NP4) RCC pipes with collars jointed with stiff mixture of cement mortar in the proportion 1:2 (1 cement : 2 sand)including testing of joints | | |
| | 150 mm Dia | Per Meter | 377 |
| | 200 mm Dia | Per Meter | 529 |
| | 250 mm Dia | Per Meter | 616 |
| | 300 mm Dia | Per Meter | 846 |
| | 350 mm Dia | Per Meter | 1382 |
| | 400 mm Dia | Per Meter | 1464 |
| | 450 mm Dia | Per Meter | 1572 |
| | 500 mm Dia | Per Meter | 1804 |
| | 600 mm Dia | Per Meter | 2076 |
| | 700 mm Dia | Per Meter | 3209 |
| | 800 mm Dia | Per Meter | 3363 |
| | 900 mm Dia | Per Meter | 3953 |
| | 1000 mm Dia | Per Meter | 4764 |
| | 1100 mm Dia | Per Meter | 5390 |
| | 1200 mm Dia | Per Meter | 5834 |
| 13.12 | Labour only for Laying & jointing non-pressure (NP4) RCC pipes with collars jointed with stiff mixture of cement mortar in the proportion 1:2 (1 cement : 2 sand) including testing of joints. | | |
| | 150 mm Dia | Per Meter | 72 |
| | 200 mm Dia | Per Meter | 96 |
| | 250 mm Dia | Per Meter | 119 |
| | 300 mm Dia | Per Meter | 127 |
| | 350 mm Dia | Per Meter | 141 |
| | 400 mm Dia | Per Meter | 147 |
| | 450 mm Dia | Per Meter | 162 |
| | 500 mm Dia | Per Meter | 171 |
| | 600 mm Dia | Per Meter | 203 |
| | 700 mm Dia | Per Meter | 225 |
| | 800 mm Dia | Per Meter | 242 |
| | 900 mm Dia | Per Meter | 303 |
| | 1000 mm Dia | Per Meter | 383 |
| | 1100 mm Dia | Per Meter | 467 |
| | 1200 mm Dia | Per Meter | 576 |

CHAPTER- XIV

DOUBLE WALL CORRUGATED (DWC) PIPES

CHAPTER- XIV

DOUBLE WALL CORRUGATED (DWC) PIPES

- **Dimensions of Pipes:** (i) Mean outside diameter :- The mean outside diameter, outside diameter at any point and tolerances shall be as give in the table 1 of IS 15328 and shall be measured according to the method in IS:12235 (part-1). (ii) Wall thickness:- The nominal wall thickness, e, shall be in accordance with table 2 of IS 15328. Tolerances in outside diameters shall be those given in IS 4985.
- **Marking:-**The colour of marking shall be different from the basic colour of the pipe. It shall be as under. (i) Identification of the source of manufacture. (ii) Outside diameter, (iii) Stiffness class, and (iv) Batch or lotnumber
- **Joints:**Elastomeric Sealing rings:- Elastomeric sealing rings shall be freefrom substances (for example, plasticizers) that can have a detrimental effect on the polyvinyl chloride of the pipe or fittings used in conjunction with thepipes.
- **Laying of pipes** includes all precautions to guard against possible damage to the existing structure/pipes lines, cables etc., taking precautions to prevent dirt from entering the pipe ends, lowering and laying pipes and specials in the trenches with specials arrangement such as cranes, tripods with chain pulley block, use of slings of canvas etc. to fit the ends of pipes and fittings/ specials to lift and lower the same. Inspection of pipes and fittings for defects by striking with a light hammer while suspended. Laying of pipes perfectly true in alignment and to gradientetc.
- **Minimum Cover**
A minimum cover of 0.9 m should be ensured when normal truck traffic is expected and 1.8m should be ensured when heavy truck traffic is expected. Bedding and backfill material must be free from boulders, sharp stones, flints etc. Bedding should be prepared by laying on soft soil duly compacting and watering so that thickness of bedding is 100 mm to 150 mm. Please refer Drawing No.3
- Providing and supply of DWC HDPE pipes class SN8 for non pressure underground sewerage drainage application as per EN: 13476-3 is also given in the given chapter. Pipes and fittings shall be as per relevant BIS/ISO specifications. Material should be used after obtaining third party quality assurancecertificate
- **Measurement**
All measurement should be of the finished work only. The net length of pipes as laid or fixed shall be measured in running meters correct to 10mm. The portion of the pipe inside the joints shall not be included in the length of pipe work.

Excavation, refilling, masonry and concrete work wherever required shall be measured and paid for separately under relevant items of work.

- **Rates**

The rate shall include the cost of material and labour involved in all the operation described above excluding the cost of concrete which shall be paid separately.

- 9 **This USOR contains the rates of all the items without GST. No claims against GST shall be entertained at any level. GST shall be paid by the Agency/ Contractor directly to the concerning department. Howerer, All the estimates prepared on this USOR will include GST, as an extra amount as per prevailing rates on the sum of the estimate to arrive at the gross amount.**

DOUBLE WALL CORRUGATED (DWC) PIPES

| S.No. | Items | Unit | Rate in Rs. | | |
|---------|--|------|-------------|--|-------|
| 14.1 | Providing of DWC/ PE (Earlier HDPE) Pipes of renowned manufacturer duly tested and inspected i/c transportation charges, transit insurance, loading/ unloading and stacking at site/ store etc, complete. | RM | | | |
| | Internal Dia/Outer dia | | | | |
| 14.1.1 | 100 mm/ 120 mm | RM | | | 149 |
| 14.1.2 | 135 mm/ 160 mm | RM | | | 224 |
| 14.1.3 | 150 mm/ 180 mm | RM | | | 264 |
| 14.1.4 | 170 mm/ 200 mm | RM | | | 319 |
| 14.1.5 | 200 mm/ 238 mm | RM | | | 438 |
| 14.1.6 | 250 mm/ 290 mm | RM | | | 682 |
| 14.1.7 | 300 mm/ 345 mm | RM | | | 910 |
| 14.1.8 | 400 mm/ 480 mm | RM | | | 1646 |
| 14.1.9 | 500 mm/ 580 mm | RM | | | 2400 |
| 14.1.10 | 600 mm/ 715 mm | RM | | | 4137 |
| 14.1.11 | 800 mm/ 955 mm | RM | | | 6860 |
| 14.1.12 | 1000 mm/ 1200 mm | RM | | | 11174 |
| 14.2 | Laying and jointing of DWC /PE (HDPE) Pipes of renowned manufacturer duly tested, and inspected i/c transportation charges, transit insurance, loading/ unloading and stacking at site/ store etc, complete. | | | | |
| | Internal Dia/Outer dia | | | | |
| 14.2.1 | 100 mm/ 120 mm | RM | | | 24 |

| S.No. | Items | Unit | Rate in Rs. | | |
|--------------|--|-------------|---------------------|--------------------------|------------------|
| 14.2.2 | 135 mm/ 160 mm | RM | | | 26 |
| 14.2.3 | 150 mm/ 180 mm | RM | | | 38 |
| 14.2.4 | 170 mm/ 200 mm | RM | | | 38 |
| 14.2.5 | 200 mm/ 238 mm | RM | | | 38 |
| 14.2.6 | 250 mm/ 290 mm | RM | | | 48 |
| 14.2.7 | 300 mm/ 345 mm | RM | | | 92 |
| 14.2.8 | 400 mm/ 480 mm | RM | | | 92 |
| 14.2.9 | 500 mm/ 580 mm | RM | | | 148 |
| 14.2.10 | 600 mm/ 715 mm | RM | | | 148 |
| 14.2.11 | 800 mm/ 955 mm | RM | | | 192 |
| 14.2.12 | 1000 mm/ 1200 mm | RM | | | 262 |
| 14.3 | Providing fittings for structural wall polyethylene piping systems (pipe with online/offline coupler and elasticmeric sealing ring) with non-smooth external annular corrugated and smooth internal surfaces (double wall) for non – pressure underground sewerage, drainage as per IS 16098(PART-2):2013&EN 13476-3. | | | | |
| | Internal dia/Outer dia | | Coupler Rate | Sealing Ring Rate | Bend rate |
| 14.3.1 | 100 mm/ 120 mm | RM | 47.00 | 11.00 | 207 |
| 14.3.2 | 135 mm/ 160 mm | RM | 81.00 | 20.00 | 315 |
| 14.3.3 | 150 mm/ 180 mm | RM | 110.00 | 23.00 | 376 |
| 14.3.4 | 170 mm/ 200 mm | RM | 167.00 | 34.00 | 547 |
| 14.3.5 | 200 mm/ 238 mm | RM | 204.00 | 59.00 | 656 |
| 14.3.6 | 250 mm/ 290 mm | RM | 502.00 | 128.00 | 1167 |
| 14.3.7 | 300 mm/ 345 mm | RM | 1053.00 | 280.00 | 1785 |
| 14.3.8 | 400 mm/ 480 mm | RM | 1670.00 | 516.00 | 3396 |
| 14.3.9 | 500 mm/ 580 mm | RM | 2344.00 | 617.00 | 4873 |
| 14.3.10 | 600 mm/ 715 mm | RM | 3292.00 | 1623.00 | 8148 |
| 14.3.11 | 800 mm/ 955 mm | RM | 7037.00 | 3967.00 | 17129 |
| 14.3.13 | 1000 mm/ 1200 mm | RM | 10398.00 | 5908.00 | 24891 |

CHAPTER-XV
SURGE PROTECTION WORKS

CHAPTER-XV

SURGE PROTECTION WORKS

NOTES:

1. Providing and supply of zero velocity valves and air cushion valves shall be Conforming to relevant Indian Standard with third party quality assurance certificate.
2. **Zero Velocity Valve**
3. The principle behind the design of this valve is to arrest the forward moving water column at zero momentum i.e. when its velocity is zero and before any return velocity is established.
4. The valve fitted in the pipeline consists of an outer shell and an inner fixed dome leaving a streamlined annular passage for water. A closing disc is mounted on central and peripheral guide rods and is held in the closed position by one or more springs when there is no flow of water.
5. A bypass connects the upstream and downstream sides of the disc. The springs are so designed that the disc remains in fully open position for velocity of water equal to 25% of the designed maximum velocity in the pipeline.
6. With sudden stoppage of pumps the forward velocity of water column goes on decreasing due to friction and gravity. When the forward velocity becomes less than 25% of the maximum, the flap starts closing at the same rate as the velocity of water.
7. The flap comes to the fully closed position when forward velocity approaches zero magnitude, water column on the upstream side of the valve is thus prevented from acquiring a revised velocity and taking part in creating surge pressures. The bypass valve maintains balanced pressures on the disc and also avoids vacuum on the downstream side of valve if that column experiences.
 - The main advantages of zero velocity valves are:
 - Controlled closing characteristics, and
 - Low loss of head due to streamlined design.

8. **Air Cushion Valve**

9. The principle of this valve is to allow large quantities of air in the pumping main during separation, entrap the air, compress it with the returning air column and expel the air under controlled pressure so as to dissipate the energy of the returning water column. An effective air cushion is thus provided.

10. The valve is mounted on TEE-joint on the rising main at locations where water column separation is likely. The valve has a spring loaded air inlet port, an outlet normally closed by a float, a spring loaded outlet poppet valve and an adjustable needle valve control orifice.

11. When there is sudden stoppage of pump due to power failure, partial vacuum is created in the main. With differential pressure, the spring loaded port opens and admits outside air into the main.

12. When the pressure in the main becomes near atmospheric, the inlet valve closes under spring pressure. The entrapped air is then compressed by the returning water column till the poppet valve opens. With float in dropped position, the air is expelled through poppet valve and controlled orifice under predetermined pressure thus dissipating the energy of the returning water column.

13. **Measurement**

Zero velocity valves and Air cushion valves shall be enumerated.

14. **Rate**

14.1 The rate shall include cost of all the materials and labour involved in the all the operation described in the item.

14.2 **This USOR contains the rates of all the items without GST. No claims against GST shall be entertained at any level. GST shall be paid by the Agency/ Contractor directly to the concerning department. Howerer, All the estimates prepared on this USOR will include GST, as an extra amount as per prevailing rates on the sum of the estimate to arrive at the gross amount.**

SURGE PROTECTION WORKS

| Sr. No. | Description of Item | Unit | Rate is Rs |
|---------|---|------|---------------|
| 15.1 | Providing and supply of Zero Velocity Valves of renowned make duly tested inclusive of all taxes related to central, state and municipal, inclusive of excise duty, inspection charges, transportation charges, transit insurance, loading/unloading and stacking at site/ store etc, complete. | | |
| 15.1.1 | 100mm 10 kg/cm ² | Each | 77326 |
| 15.1.2 | 100mm 15 kg/cm ² | Each | 83224 |
| 15.1.3 | 100mm 20 kg/cm ² | Each | 85189 |
| 15.1.4 | 100mm 25 kg/cm ² | Each | 97771 |
| 15.1.5 | 150mm 10 kg/cm ² | Each | 99474 |
| 15.1.6 | 150mm 15 kg/cm ² | Each | 106945 |
| 15.1.7 | 150mm 20 kg/cm ² | Each | 117693 |
| 15.1.8 | 150mm 25 kg/cm ² | Each | 135254 |
| 15.1.9 | 200mm 10 kg/cm ² | Each | 103931 |
| 15.1.10 | 200mm 15 kg/cm ² | Each | 111795 |
| 15.1.11 | 200mm 20 kg/cm ² | Each | 122934 |
| 15.1.12 | 200mm 25 kg/cm ² | Each | 141545 |
| 15.1.13 | 250mm 10 kg/cm ² | Each | 117299 |
| 15.1.14 | 250mm 15 kg/cm ² | Each | 126211 |
| 15.1.15 | 250mm 20 kg/cm ² | Each | 138662 |
| 15.1.16 | 250mm 25 kg/cm ² | Each | 159500 |
| 15.1.17 | 300mm 10 kg/cm ² | Each | 132109 |
| 15.1.18 | 300mm 15 kg/cm ² | Each | 141938 |
| 15.1.19 | 300mm 20 kg/cm ² | Each | 156093 |
| 15.1.20 | 300mm 25 kg/cm ² | Each | 179290 |
| 15.1.21 | 350mm 10 kg/cm ² | Each | 136827 |
| 15.1.22 | 350mm 15 kg/cm ² | Each | 147181 |
| 15.1.23 | 350mm 20 kg/cm ² | Each | 161728 |
| 15.1.24 | 350mm 25 kg/cm ² | Each | 186105 |
| 15.1.25 | 400mm 10 kg/cm ² | Each | 151243 |
| 15.1.26 | 400mm 15 kg/cm ² | Each | 162515 |
| 15.1.27 | 400mm 20 kg/cm ² | Each | 178897 |
| 15.1.28 | 400mm 25 kg/cm ² | Each | 205765 |
| 15.1.29 | 450mm 10 kg/cm ² | Each | 175883 |
| 15.1.30 | 450mm 15 kg/cm ² | Each | 189120 |
| 15.1.31 | 450mm 20 kg/cm ² | Each | 207992 |
| 15.1.32 | 450mm 25 kg/cm ² | Each | 239317 |
| 15.1.33 | 500mm 10 kg/cm ² | Each | 203275 |
| 15.1.34 | 500mm 15 kg/cm ² | Each | 218477 |

| Sr. No. | Description of Item | Unit | Rate is Rs |
|----------------|----------------------------|-------------|-------------------|
| 15.1.35 | 500mm20 kg/cm2 | Each | 240496 |
| 15.1.36 | 500mm25 kg/cm2 | Each | 276669 |
| 15.1.37 | 600mm10 kg/cm2 | Each | 249146 |
| 15.1.38 | 600mm15 kg/cm2 | Each | 267888 |
| 15.1.39 | 600mm20 kg/cm2 | Each | 294624 |
| 15.1.40 | 600mm25 kg/cm2 | Each | 338791 |
| 15.1.41 | 700mm10 kg/cm2 | Each | 351373 |
| 15.1.42 | 700mm15 kg/cm2 | Each | 377716 |
| 15.1.43 | 700mm20 kg/cm2 | Each | 415461 |
| 15.1.44 | 700mm25 kg/cm2 | Each | 477847 |
| 15.1.45 | 750mm10 kg/cm2 | Each | 397375 |
| 15.1.46 | 750mm15 kg/cm2 | Each | 427256 |
| 15.1.47 | 750mm20 kg/cm2 | Each | 469852 |
| 15.1.48 | 750mm25 kg/cm2 | Each | 540494 |
| 15.1.49 | 800mm10 kg/cm2 | Each | 438528 |
| 15.1.50 | 800mm15 kg/cm2 | Each | 471424 |
| 15.1.51 | 800mm20 kg/cm2 | Each | 471424 |
| 15.1.52 | 800mm25 kg/cm2 | Each | 596587 |
| 15.1.53 | 900mm10 kg/cm2 | Each | 521358 |
| 15.1.54 | 900mm15 kg/cm2 | Each | 560545 |
| 15.1.55 | 900mm20 kg/cm2 | Each | 616377 |
| 15.1.56 | 900mm25 kg/cm2 | Each | 709037 |
| 15.1.57 | 1000mm10 kg/cm2 | Each | 662904 |
| 15.1.58 | 1000mm15 kg/cm2 | Each | 712576 |
| 15.1.59 | 1000mm20 kg/cm2 | Each | 783741 |
| 15.1.60 | 1000mm25 kg/cm2 | Each | 901565 |
| 15.1.61 | 1100mm10 kg/cm2 | Each | 813230 |
| 15.1.62 | 1100mm15 kg/cm2 | Each | 874304 |
| 15.1.63 | 1100mm20 kg/cm2 | Each | 961722 |
| 15.1.64 | 1100mm25 kg/cm2 | Each | 1106019 |
| 15.1.65 | 1200mm10 kg/cm2 | Each | 1003268 |
| 15.1.66 | 1200mm15 kg/cm2 | Each | 1078628 |
| 15.1.67 | 1200mm20 kg/cm2 | Each | 1186359 |
| 15.1.68 | 1200mm25 kg/cm2 | Each | 1364470 |
| 15.1.69 | 1300mm10 kg/cm2 | Each | 1444810 |
| 15.1.70 | 1300mm15 kg/cm2 | Each | 1535896 |
| 15.1.71 | 1300mm20 kg/cm2 | Each | 1635372 |
| 15.1.72 | 1300mm25 kg/cm2 | Each | 1796969 |
| 15.1.72 | 1400mm10 kg/cm2 | Each | 1576919 |
| 15.1.73 | 1400mm15 kg/cm2 | Each | 1695135 |
| 15.1.74 | 1400mm20 kg/cm2 | Each | 1864597 |
| 15.1.75 | 1400mm25 kg/cm2 | Each | 2144411 |
| 15.1.76 | 1500mm10 kg/cm2 | Each | 241177 |
| 15.1.77 | 1500mm15 kg/cm2 | Each | 2160400 |
| 15.1.78 | 1500mm25 kg/cm2 | Each | 2733003 |

| Sr. No. | Description of Item | Unit | Rate is Rs |
|----------------|---|-------------|-------------------|
| 15.2 | Providing and supply of Air cushion Valves of renowned make duly tested inclusive of all taxes related to central, state and municipal, inclusive of excise duty, inspection charges, transportation charges, transit insurance, loading/unloading and stacking at site etc, complete | | |
| 15.2.1 | 100 mm TP 10 kg/cm ² | Each | 86238 |
| 15.2.2 | 100 mm TP 15 kg/cm ² | Each | 94756 |
| 15.2.3 | 100 mm TP 20 kg/cm ² | Each | 104193 |
| 15.2.4 | 100 mm TP 25 kg/cm ² | Each | 119920 |
| 15.2.5 | 150 mm TP 10 kg/cm ² | Each | 130798 |
| 15.2.6 | 150 mm TP 15 kg/cm ² | Each | 143774 |
| 15.2.7 | 150 mm TP 20 kg/cm ² | Each | 158190 |
| 15.2.8 | 150 mm TP 25 kg/cm ² | Each | 181911 |
| 15.2.9 | 200 mm TP 10 kg/cm ² | Each | 139580 |
| 15.2.10 | 200 mm TP 15 kg/cm ² | Each | 153603 |
| 15.2.11 | 200 mm TP 20 kg/cm ² | Each | 168937 |
| 15.2.12 | 200 mm TP 25 kg/cm ² | Each | 194100 |
| 15.2.13 | 300 mm TP 10 kg/cm ² | Each | 196329 |
| 15.2.14 | 300 mm TP 15 kg/cm ² | Each | 216119 |
| 15.2.15 | 300 mm TP 20 kg/cm ² | Each | 248491 |
| 15.2.16 | 300 mm TP 25 kg/cm ² | Each | 285712 |

CHAPTER-XVI
SMOOTH FLOW PIPES

CHAPTER - XVI SMOOTH FLOW PIPES

NOTES:-

1. Applicable Codes:-

| | |
|-----------------|---|
| IS: 3589 | Seamless/Electrically Welded Steel Pipes for Water, Gas, Sewage Specification. |
| IS: 5822 | Code of Practice for laying of Electrically Welded Steel Pipes for Water Supply. |
| IS : 7322 | Specification for Specials for Steel Cylinder Reinforced Concrete Pipes |
| IS: 432 Part I | Mild Steel and Medium Tensile Bars Reinforcement |
| IS: 432 Part II | Specifications for Mild Steel and Medium Tensile Bars and Hard Drawn Steel Wire (Third Revision) |
| IS: 2328 | Flattening Test for Seamless Pipes |
| IS: 6452 | Specification for High Alumina Cement for Structural Use (Ist Revision) |
| IS: 4853 | Recommended Practice for Radiographic Inspection of Fusion Welded Butt Joints in Steel Pipes (First Revision) |
| IS: 4260 | Recommended Practice for Ultrasonic Butt Welds in Ferric Steel |
| IS: 3600 Part I | Methods of Testing Fusion Welded Joints and Weld Metal in Steel |

Other I.S. Codes not specifically mentioned here but pertaining to the use of Electrically Welded Steel pipes shall form part of these Specifications.

2. The Smooth flow pipes shall be 3 Layer Polyethylene (3 LPE) coated & fusion bonded Epoxy lined Steel pipes for drinking water supply Application.
3. External 3 LPE coating shall be done as per Canadian Standard CSA Z245.20 & 21
4. Internal lining of Fusion Bond Epoxy (FEB) will be as per IS 3589 Annex "C".
5. Steel Pipes shall be as per Indian Standard IS 3589.
6. External coating shall be 3 layer polyethylene for buried or submerged application and dual layer fusion bonded epoxy for above ground pipe installation.

7. Internal lining shall be potable water contact approved fusion bonded epoxy.
8. Pipes on both the ends shall have steel ring 50mm long and 2mm extra thickness over and above the pipe thickness on each pipes upto 600mm dia only.
9. Pipes can be specially designed upto 6.3 Mpa depending on OD & thickness.
10. These pipes should be food grade approved for potable water.

11. **Measurement:**

The net length of pipes as laid or fixed should be measured in running meters correct to a cm. Specials should be excluded and enumerated and paid for separately.

12 **Rates:-**

- 12.1 The rates include charges for all tools & plants, chain pulley blocks, other appliances etc. required for lifting and laying the pipes and specials in positions as per approved drawing.
- 12.2 The rates include provision and use of all coverings etc. to protect the works from inclement weather etc. and from damages from fall of materials, and other causes
- 12.3 **This USOR contains the rates of all the items without GST. No claims against GST shall be entertained at any level. GST shall be paid by the Agency/ Contractor directly to the concerning department. Howerer, All the estimates prepared on this USOR will include GST, as an extra amount as per prevailing rates on the sum of the estimate to arrive at the gross amount.**

SMOOTH FLOW PIPES

| Sr. No. | Description of Item | Unit | Rate in Rs. |
|-------------|--|------|-------------|
| 16.1 | Providing, laying, Jointing & field testing of Smooth Flow Pipes (3 Layer Polyethylene -3LPE) Coated & fusion bonded Epoxy lined Steel pipes) for drinking water purposes for underground application with necessary jointing material having working pressure of 10Kg/sq.cm., cost of pipes & jointing material complete as per relevant IS specification complete as directed by the Engineer-in-charge. | | |
| 16.1.1 | 300mm | RM | 5787 |
| 16.1.2 | 350mm | RM | 6755 |
| 16.1.3 | 400mm | RM | 7721 |
| 16.1.4 | 450mm | RM | 8616 |
| 16.1.5 | 500mm | RM | 9517 |
| 16.1.6 | 550mm | RM | 11894 |
| 16.1.7 | 600mm | RM | 12951 |
| 16.1.8 | 700mm | RM | 16491 |
| 16.1.9 | 750mm | RM | 17651 |
| 16.1.10 | 800mm | RM | 18901 |
| 16.1.11 | 900mm | RM | 21208 |
| 16.1.12 | 1000mm | RM | 25887 |
| 16.1.13 | 1200mm | RM | 31054 |
| 16.1.14 | 1400mm | RM | 39798 |
| 16.1.15 | 1500mm | RM | 42597 |
| 16.1.16 | 1600mm | RM | 45425 |
| 16.1.17 | 1800mm | RM | 51037 |
| 16.1.18 | 2000mm | RM | 66092 |
| 16.2 | Providing, laying, Jointing & field testing of Smooth Flow Pipes (3 Layer Polyethylene-3LPE) Coated & fusion bonded Epoxy lined Steel pipes) for drinking water purposes for underground application with necessary jointing material having working pressure of 20Kg/sq.cm., cost of pipes & jointing material complete as per relevant IS specification complete as directed by the Engineer-in-charge. | | |

| Sr. No. | Description of Item | Unit | Rate in Rs. |
|----------------|----------------------------|-------------|--------------------|
| 16.2.1 | 300mm | RM | 6473 |
| 16.2.2 | 350mm | RM | 7510 |
| 16.2.3 | 400mm | RM | 8544 |
| 16.2.4 | 450mm | RM | 9577 |
| 16.2.5 | 500mm | RM | 10616 |
| 16.2.6 | 550mm | RM | 13041 |
| 16.2.7 | 600mm | RM | 14201 |
| 16.2.8 | 700mm | RM | 18143 |
| 16.2.9 | 750mm | RM | 19424 |
| 16.2.10 | 800mm | RM | 20793 |
| 16.2.11 | 900mm | RM | 25462 |
| 16.2.12 | 1000mm | RM | 28261 |
| 16.2.13 | 1200mm | RM | 33896 |
| 16.2.14 | 1400mm | RM | 46415 |
| 16.2.15 | 1500mm | RM | 49562 |
| 16.2.16 | 1600mm | RM | 53001 |
| 16.2.17 | 1800mm | RM | 59567 |
| 16.2.18 | 2000mm | RM | 75548 |

CHAPTER- XVII
SEWER APPURTENANCES

CHAPTER- XVII SEWER APPURTENANCES

SEWER APPURTENANCES

Following are the General Sewer Appurtenances-

- (I) Manholes
- (II) Inverted Siphons
- (III) Storm Water Inlets
- (IV) Sewer Ventilators

Out of the above, manholes are the most essential items in any sewerage system.

1 Manholes **Function**

Manholes is the essential ancillary structure in any sewerage system. They shall be provided for inspection, testing, cleaning, repairing and removal of obstruction from sewer line.

Provision:-

Manholes should be built at every change of alignment, gradient or diameter, at the head of all sewer and branches and at every junction of two or more sewers, on sewer, which is to be cleaned manually or which cannot be entered for cleaning or inspection.

Spacing:-

The Maximum spacing of manholes in the sewer shall be kept as follows: -

| <u>Pipe dia (mm)</u> | <u>Max. Spacing (mt)</u> |
|----------------------|--------------------------|
| Upto 900 | 30 |
| 900 to 1500 | 90-150 |
| 1500 to 2000 | 150-200 |
| Above 2000 | 300 |

A spacing allowance of 100m per 1m dia of sewer is a general rule in case of very large sewers.

Types of manholes:

Following is the general classification of manholes-

Straight-through manholes:-

The simplest type of manhole is that built on a straight run of sewer with no side junctions. Where there is a change in the size of sewer, the soffit or crown level of the two sewers should be the same, except where special conditions require otherwise.

Junction Manholes:-

A manhole should be built at every junction of two or more sewers, and the curved portions of the inverts of tributary sewers should be formed within the manhole. To achieve this with the best economy of space, the chamber may be built of a shape other than rectangular. The soffit of the smaller sewer at a junction should be not lower than that of the larger sewer, in order to avoid the surcharging of the former when the latter is running full, and the hydraulic design usually assumes such a condition. The gradient of the smaller sewer may be increased from the previous manhole sufficiently to reduce the difference of invert level at the point of junction to a convenient amount.

Side Entrance Manholes:-

In large sewer or where it is difficult to obtain direct vertical access to the sewer from ground level, owing to existing services, gas, water etc. the access shaft should be constructed in the nearest convenient position off the line of sewer, and connected to the manhole chamber by a lateral passage.

In the tunnelled sewer the shaft and the lateral access heading may be used as a working shaft, the tunnel being broken out from the end of the heading, or alternatively the shaft and heading may be used as a working shaft, the tunnel being broken out from the end of the heading, or alternatively the shaft and heading maybe constructed after the main tunnel is completed, provision having been made for breaking in from the access heading to build the chamber.

The floor of the side-entrance passage, which should fall at about 1 in 30 towards the sewer, should enter the chamber not lower than the soffit level of the sewer. In large sewer where the floor of the side entrance passage is above the soffit either steps or a ladder (which should be protected either by a removable handrail or by safety chains) should be provided to reach the benching.

Drop Manholes:-

When a sewer connects with another sewer, where the difference in level between water lines (peak flow levels) of main line and the invert level of branch line is more than 600 mm or a drop of more than 600 mm is required to be given in the same sewer line and it is uneconomical or impractical to arrange the connection within 600 mm a drop connection shall be provided for which is manholes maybe built incorporating a vertical or nearly vertical drop pipe from the higher sewer to the lower one. This pipes maybe either outside the shaft and enclosed in concrete or supported on brackets inside the shaft, which should be suitably enlarged. If the drop pipe is outside the shaft, a continuation of the sewer should be built through the shaft wall to form a rodding and inspection eye, which should be provided with a half blank flange. If the drop pipe is inside the shaft. It should be in cast iron and it would be advantageous to

provide adequate means for rodding and water cushion of 150 mm depth should also be provided. The diameter of the backdrop should be at-least as large as that of the incoming pipe

The drop pipe should terminate at its lower end with a plain or duck-foot bend turned so as to discharge its flow at 45 degree or less then to the direction of the flow in the main sewer and the pipe, unless of cast iron, should be surrounded with 150 mm of concrete.

In the case of sewer over 450 mm in diameter the drop in level may be accomplished by one of the following methods: -

(a) A cascade: - This is a steep ramp composed of steps over which the flow is broken up and retarded. A pipe connecting the two levels is often concreted under the steps to allow small flow to pass without trickling over the steps. The cascade steps maybe made of heavy-duty bricks of class- I quality (IS: 2180- 1985) cement concrete with granolithic finish or dressed granite.

(b) A Ramp: - A ramp maybe formed by increasing the grade of the last length of the upper sewer to about 45 degrees or by constructing a steeply graded channel or culvert leading from the high level to the low level sewer. In order to break up the flow down the ramp and minimize the turbulence in the main sewer the floor of culvert ramp should be obstructed by riced transverse ribs of either bricks or concrete at 1.50m intervals and a stilling pool provided at the bottom of the ramp and

(c) By drop in previous successive manholes instead of providing the total drop require at the junction manholes, the same may be achieved by giving smaller drops in successive manhole preceding the junction manhole. Thus, for example, if a total drop of 2.4m is required to be given, 0.6m drop maybe given in each of the previous three manholes and the last 0.6m-drop maybe given at the junction manhole.

Scraper (Service) Type Manhole:-

All sewers above 450mm diameter should have manhole at intervals for 110 to 120 m of scraper type. This manhole should have clear opening of 1200 x 900 mm at top to facilitate lowering of buckets.

Flushing manholes:-

Where it is not possible to obtain self-cleaning velocities due to flatness of the gradient specially at the top end of branch sewer which receive very little flow, it is essential that same form of flushing device be incorporated in the system. This can be done by making grooves at intervals of 45 to 50m in the main drains in which wooden planks are inserted & water allow to head up and which will rush on with great velocity when the planks are removed. Alternatively, an overhead water tanks is built, from which connection are made through pipe flushing hydrants to rush water to the sewer. The relevant Indian standard is IS:

4111(part two).Flushing can be very conveniently accomplished by use of fire hydrant or tanker.

Where flushing manhole is provided, they are located generally at the head of a sewer. Sufficient velocity shall be imparted in the sewer to wash away the deposited solid. The flush is usually effective up to a certain distance after which the imparted velocity gets dissipated.

The automatic systems which are operated by mechanical units gets often corroded by the sewer gases and do not generally function satisfactorily and hence are not recommended. In case of hard chock ages in sewers, care should be exercised to be ensuring that there is no possibility or back flow of sewer into the water supply mains.

Approximate quantities of water needed for flushing are as follows: -

| No. | Slope | Quantity of water (litres) | | |
|-----|--------|----------------------------|----------|----------|
| | | 200mmdia | 250mmdia | 300mmdia |
| 1 | 1: 200 | 2300 | 2500 | 3000 |
| 2 | 1: 133 | 1500 | 1800 | 2300 |
| 3 | 1: 100 | 1300 | 1500 | 2000 |
| 4 | 1: 50 | 500 | 800 | 1000 |
| 5 | 1: 33 | 400 | 500 | 700 |

2. Constructional Details:-

Manhole is usually constructed directly over the centre line of the sewer they are usually constructed with brickwork. However in areas where sewers are to be laid in high water condition manhole shall be constructed in R.C.C. They are circular, rectangular or square in shape. Manholes should be of such size as will allow necessary cleaning and inspection of manholes.

- (a) **Rectangular Manholes** - The minimum internal sizes of rectangular manholes between brick face should be as follows:
- (i) For depth of manholes less than 0.9m, 900mm x 800mm and
 - (ii) For depths of manholes from 0.9m and upto 2.5m, 1200mm x 900mm
- (j) **Arch type manholes** - For depth of 2.5m and above, arch type manholes can be provided and the internal size of the chambers between brick faces shall be 1400mm x 900mm. The width of manhole chamber on bents and junction of pipes with diameter greater than 450mm should be suitably increased to 900mm or more so that benching width on either side of the channel at-least 200mm.

3. Circular manholes-

Circular manholes are longer than rectangular and arch type manhole and thus there are preferred over rectangular as well as arch type manholes. The circular manholes can be provided for all depths starting from 0.9m circular manholes are straight down in lower portion and slanting into proportion so as to narrow down

the top opening equal to internal dia.of manhole over. Depending upon the depth of manhole, the diameter of manhole changes. The internal diameter of circular manholes may be kept as following for verifying depths.

- For depths 0.9m and up to 1.65m, 900mm diameter.
- For depths above 1.65m and up to 2.30m, 1200mm diameter.
- For depths above 2.30m and up to 9.0m, 1500mm diameter.
- For depths above 9.0m and up to 14.0m, 1800mm diameter.

Typical circular manholes are shown in fig.6

If the sewer is constructed in a tunnel, the manhole should be located at the access or working shaft and the manhole chamber maybe constructed of a size to suit the working shaft or vice-versa.

The width /diameter of the manhole should not be less than internal diameter of the sewer +150mm benching as both sides (150mm+ 150mm) The opening for entry into the manhole (without cover) should be such minimum diameters as to allow a workman with the cleaning equipments into the interior of the manhole without difficulty. A minimum clear opening of 60cm preferably circular is recommended. Suitable steps usually cast iron shall be provided for entry.

Access shaft for large sewers - Access shaft shall be circular in shape and shall have a minimum internal dia of 750mm, where the depth of the shaft exceeds 3m suitable dimensions shall be provided to facilitate cleaning and maintenance.

Access shaft where built of brick work should be carvel led on three sides to reduce it to the size of the opening in the cover frame, and to provide easy access on the fourth side to step iron or ladder .In determining sizes the dimensions of the maintenance equipments likely to be used in sewer, shall be kept in view.

Where the diameter of the sewer is increased, the crown of the entering leaving pipes shall be fixed at the same level and necessary slopes given in the inverted of the manholes chamber .In exceptional cases and where unavoidable the crown of the entering sewer maybe fixed at lower level but in each cases too the peak flow level of the two sewer shall be kept the same.

A slab generally of plain cement concrete at least 150mm thick should be provided at the base to support the walls of the manhole and to prevent the entry of foul water. The thickness of the base also shall be suitably increased up to 300mm, for manholes on large dia sewers, with adequate reinforcement provided to withstand excessive uplift pressures. In the case of larger manholes, the flow in the sewer should be carried in U-Shaped smooth channel constructed integrally with the concrete base of the manhole. The side of the channel should be equal to the dia. of the largest sewer pipe. The adjacent floor should have a

slope of 1 in 10 draining to the channel. Where more than one sewer enters the manhole the flow through channel should be curved smoothly and should have sufficient capacity to carry the maximum flow.

It is desirable to place the first pipe joint outside the manhole as close as practicable. The pipe shall be built inside the wall of the manhole flush with the internal periphery protected with an arch of masonry or cement concrete to prevent it from being crushed.

The sidewalls of the manhole are usually constructed of cement brickwork 250mm thick and corbelled suitably to accommodate the frame of the manhole cover.

The inside and outside of the brickwork should be plastered with cement mortar 1:3 (1 cement: 3 coarse sand) and inside finished smooth with a coat of neat cement.

Where subsoil water condition exist, a richer mix may be used and it shall further be water proofed with addition of approved water proofing compound in a quantity as per manufacturer's specifications.

4. Covers and frames: -

The size of manhole covers should be such that there should be clear opening of not less than 560mm diameter for manholes exceeding 0.9m depths. When cast iron manhole covers and frames are used they shall conform to IS 1726 (parts 1 to 7). The frames of manhole shall be firmly embedded to correct alignment and level in plain concrete on the top of masonry. After completion of the work, manhole covers shall be sealed by means of thick grease.

Where sewer are to be laid in high subsoil water conditions, manholes maybe constructed in R.C.C. of grade M 20 or 1:1.5:3. The manholes in this type of construction shall be preferably circular.

Heavy reinforced concrete covers with suitable lifting arrangements could also be used instead of C.I manhole covers. However pre-cast cement concrete covers reinforced by materials other than mild steel should be used provided that those are properly tested & certified for use by competent authority. Fibre reinforcement plastic covers (FRP) conforming to relevant IS: may be used wherever such covers are available.

5. Inverted siphon

Function and provision

In the course of laying sewers, at times it is found necessary to cross obstructions like nallah etc. Such obstruction shall be crossed by means of "Inverted Syphon" i.e. by laying the sewer under the obstruction and regaining as much elevation as possible after the obstruction is passed. As the siphons are depressed below the hydraulic grade line, maintenance of self cleaning velocity at all flows is very important. Two considerations, which govern the profile of a siphon, are

provision for hydraulic losses and ease of cleaning.

Construction

To ensure self-cleaning velocities for the wide variations in flows, generally, two or more pipes not less than 200mm dia are provided in parallel so that up to the average flows, first pipe is used and when the flow exceeds the average, the second and subsequent pipes take the balance flow. Siphons may need cleaning other than gravity sewers and hence should not have any sharp bends either horizontal or vertical. Only smooth curves of adequate radius should be used. The design criteria for inverted siphons are given in IS: 411 part -III. It is necessary to have a self-cleaning velocity of 1.0 mps for the minimum flow to avoid deposition in the line. Provision should be made for isolating the individual pipes as well as the siphon to facilitate cleaning. It is desirable to provide a coarse screen to prevent the entry of rags etc, into the siphon.

Inlet and outlet chambers:-

In the multiple pipe siphon, the inlet should be such that the pipes come into action successively as the flow increases. This may be achieved by providing lateral with heights kept in accordance with the depth of flow at which one or more siphon pipes function. In the two-pipe siphon, the first should take 1.25 to 1.5 times the average flow and second should take the balance of the flow.

A manhole at each end of the siphon should be provided with clearance for rodding. The design of inlet and outlet chambers should allow sufficient room for entry for cleaning and maintenance of siphons. The outlet chambers should be so designed as to prevent the flow of sewage into pipes, which are not being used at the time of minimum flow.

6. Hatchbox:

Hatch boxes of adequate size in manholes shall be provided on the pipes so as to give access into the pipes for rodding.

7. By pass:

Proper by pass arrangements should be provided from the inlet chamber and if required special arrangements should be made for pumping the sewage to the lower reach of sewer line. Alternatively a vacuum pump may be provided at the outlet to overcome maintenance problems arising out of dogging and silting of siphons. If it is possible a blow off may be installed at the low point to facilitate emergency maintenance operations.

8 Storm water inlets:-

There are devices meant to admit the surface runoff to the sewers and form a very important part of the systems. Their location and design should therefore be given careful considerations.

Storm water inlets may be categorised under three major groups viz. curb inlets, gutter inlets and combination inlets, each being either depressed or flush depending upon their elevation with reference to the pavement surface.

The actual structure of an inlet is usually made of brickwork. Normally cast-iron

gratings conforming to IS: 5961 shall be used. In case there is no vehicular traffic, fabricated steel gratings may be used. The clear opening shall not be more than 25mm. The connecting pipe from the street inlet to the main street sewer should not be less than 200mm in dia. and should have sufficient slope.

Maximum spacing of inlets would depend upon various conditions of road surface, size and type of inlet and rainfall. A maximum spacing of 30m is recommended.

9. Sewer ventilators:-

In a modern, well designed sewerage system, there is no need to provide ventilation on such elaborate scale considered necessary in the past, especially with the present day policy to omit intercepting traps in house connections. The ventilating columns/shafts are not necessary where intercepting traps are not provided. It is necessary however, to make provision for the escape of air to take care of the exigencies of full flow and also to keep the sewage as fresh as possible especially in outfall sewers. In case of storm sewers providing ventilating manhole covers can do these.

9.1 Provision:-

Ventilating columns/ shafts shall be provided at an interval of 180m in all mains intercepting and outfall sewers, near the manholes. The connections of house drains to the sewer shall be allowed without the use of any intercepting trap and thus permitting ventilation of laterals and branch sewers via. House drains and their ventilating pipes.

9.2. Construction: -

The ventilating shaft shall consist of vertical columns of R.C.C. or cast iron about 6 to 8 metre in height and about 100 to 150mm in diameter (opening) at the top, the diameter increasing uniformly towards the bottom for stability. The shaft shall be provided with a Crowell or fitted with a wire ground at the top.

- 10 This USOR contains the rates of all the items without GST. No claims against GST shall be entertained at any level. GST shall be paid by the Agency/ Contractor directly to the concerning department. However, All the estimates prepared on this USOR will include GST, as an extra amount as per prevailing rates on the sum of the estimate to arrive at the gross amount.**

SEWER APPURTENANCES

| S.No. | Items | Unit | Rate (Rs.) |
|------------------|--|------|---------------|
| 17.1 | Providing and fixing SW gully trap complete with CI grating, Brick masonry chamber in cement mortar 1:5 (1 cement :5 fine sand) water tight CI cover with frame of 30x30cm size including necessary Excavation, cement concrete CC 1:5:10 (1 cement: 5 fine sand: 10 graded stone aggregate 40mm size),CC 1:2:4(1cement:2coarse sand:4 graded stone aggregate 20mm nominal size) for fixing CI cover with frame,12 mm thick cement plaster 1:2 (1 cement:2 coarse sand) finished with a floating coat of neat cementcomplete. | | |
| 17.1.1 | 100x100mm size "P" Gully Trap Chamber | Each | 1881 |
| 17.1.2 | 125x100mm size "P", "Q" or "S" type Gully trap chamber | Each | 1959 |
| 17.1.3 | 180x150mm size "P" or "S" type | Each | 2053 |
| MAN HOLES | | | |
| 17.2 | Constructing Brick Masonry Manhole in Cement Mortar 1 :4 (1 cement : 4 fine sand) R.C.C. top slab 1:1.5:3 (1 cement : 1.5 coarse sand : 3 graded stone aggregate 20 mm nominal size), foundation concrete 1:4:8 mix (1cement : 4 coarse sand : 8 graded stone aggregate 40mm nominal size) inside plastering 12mm thick with cement mortar 1:3 (1cement : 3 fine sand) finished with a floating coat of neat cement and making channels in CC 1:2:4 (1 cement : 2 coarsesand : 4 graded stone aggregate 20mm nominal size) including finishing the channel to shape, curing etc. (Excavation foot rest and external cementplaster shall be paid for separately) | | |
| 17.2.1 | Inside size 90x80 cm and 45 cm deep including CI cover with frame 455x610 mm internal dimensions total weight of cover and frames to be not less than (23+15) 38 kg. | Each | 9627 |
| 17.2.2 | Inside size 90x80 cm and 60 cm deep including CI cover with frame 455x610mm internal dimensions totalweightofcoverandframestobenotlessthan (23+15) 38kg | Each | 10438 |

| S.No. | Items | Unit | Rate (Rs.) |
|--------|--|-----------|------------|
| 17.2.3 | Inside size 120x90 cm and 90 cm deep Manhole including CI cover with frame (medium duty) 500 mm internal diameter total weight of cover and frame to be not less than (58+58) 116 kg. | Each | 20777 |
| 17.2.4 | Inside size 120x90 cm and 90 cm deep Manhole including CI cover with frame (Heavy duty) 560 mm internal diameter total weight of cover and frame to be not less than (108+100) 208 kg. | Each | 27793 |
| 17.2.5 | Manhole for property (House) connection | | |
| (i) | Inside size 60x60 cm and 90 cm deep manhole with fixing of ISI marked pre cast RCC manhole cover & frame i/c transportation etc. 600x600 mm size heavy duty. | Each | 8120 |
| (ii) | Inside size 60x45 cm and 60 cm deep manhole with fixing of ISI marked pre cast RCC manhole cover & frame i/c transportation etc. 600x450mm size heavy duty | Each | 6155 |
| 17.3 | Extra for depth up to 1.00 m for man holes over item 15.2 | | |
| 17.3.1 | 90x80cm size manhole over item | per meter | 5410 |
| 17.3.2 | 120x90cm size manhole over item. | per meter | 6465 |
| 17.3.3 | 60x60cm size manhole over item | per meter | 4092 |
| 17.3.4 | 60x45 cm size manhole over item | per meter | 3696 |
| 17.4 | Constructing Brick Masonry Circular Man Hole 1500 mm internal dia at bottom & 560 mm dia at top in cement Mortar 1:4 (1 cement: 4 fine sand), inside Cement plaster 12 mm thick with cement mortar 1:3 (1 cement : 3 fine sand) finished with a floating coat of neat cement, foundation concrete 20 cm thick in 1:3:6 (1 cement : 3 coarse sand : 6 graded stone aggregate 40 mm nominal size) and making channels in cement concrete 1:2:4 (1cement : 2 coarse sand : 4 graded stone aggregate 20mm nominal size) finishedwithafloatingcoatofneatcement etc. all complete. | | |

| S.No. | Items | Unit | Rate (Rs.) |
|--------------|--|-------------|-------------------|
| 17.4.1 | For one manhole upto 2650 mm deep with fixing of 560 mm dia ISI marked reinforcement cement concrete cover & frame heavy duty including transportation etc. in cement concrete 1:2:4 all complete. (Excavation, foot rests & cement plaster at the | Each | 25918 |
| 17.4.2 | For one manhole upto 2650 mm deep with fixing of 560 mm dia CI cover & frame (medium duty) weight not less than (58+58) 116 kg. including transportation etc. in cement concrete 1:2:4 all complete. (Excavation, foot rests & cement plaster at the | Each | 32478 |
| 17.5 | Extra for depth for circular manholes over item 15.4 | | |
| 17.5.1 | Depth 2.65m to 4.25 m | per meter | 10367 |
| 17.5.2 | Depth 4.25m to 9.75m | per meter | 14255 |
| 17.6 | Constructing Brick Masonry Circular Man Hole 1200 mm internal dia at bottom & 560 mm dia at top in cement Mortar 1:4 (1 cement: 4 fine sand), inside Cement plaster 12 mm thick with cement mortar 1:3 (1 cement : 3 fine sand) finished with a floating coat of neat cement, foundation concrete 20 cm thick in 1:3:6 (1 cement : 3 coarse sand : 6 graded stone aggregate 40 mm nominal size) and making channels in cement concrete 1:2:4 (1cement : 2 coarse sand : 4 graded stone aggregate 20mm nominal size) finished with a floating coat of neat cement etc. allcomplete. | | |
| 17.6.1 | For one manhole upto 1650 mm deep with fixing of 560 mm dia ISI marked reinforcement cement concrete cover & frame heavy duty including transportation etc. in cement concrete 1:2:4 all complete. (Excavation, foot rests & cement plaster at the | Each | 16397 |
| 17.6.2 | Add extra for depth 1.65 to 2.30 mtr. | Per Mtr. | 6558 |

| S.No. | Items | Unit | Rate (Rs.) |
|--------|---|------|------------|
| 17.7 | Constructing Brick Masonry Circular Man Hole 900 mm internal dia at bottom & 560 mm dia at top in cement Mortar 1:4 (1 cement: 4 fine sand), inside Cement plaster 12 mm thick with cement mortar 1:3 (1 cement : 3 fine sand) finished with a floating coat of neat cement, foundation concrete 20 cm thick in 1:3:6 (1 cement : 3 fine sand : 6 graded stone aggregate 40 mm nominal size) and making channels in cement concrete 1:2:4 (1 cement : 2 coarse sand : 4 graded stone aggregate 20mm nominal size) finished with a floating coat of neat cement etc. all complete. | | |
| 17.7.1 | For one Manhole 900mm deep with fixing of 560 mm dia ISI marked reinforcement cement concrete cover & frame heavy duty including transportation etc. in cement concrete 1:2:4 all complete. (Excavation, foot rests & cement plaster at the external surface shall be paid for separately) | Each | 11924 |
| 17.7.2 | Add extra for depth 0.90 to 1.65mtr. | Each | 4770 |
| 17.8 | Providing MS foot rests i/c fixing in manhole with 20x20x10cm CC blocks of 1:3:6 (1 cement:3 coarse sand : 6 graded stone aggregate 20mm nominal size) | | |
| 17.8.1 | With 20mm square bar foot rest | Each | 259 |
| 17.8.2 | With 20mm round bar foot rest | Each | 229 |
| 17.9 | Making connection of drain or sewer line with existing service lines Manhole including breaking into and making good the walls, floors etc. with cement concrete 1:2:4 (1 cement : 2 coarse sand : 4 graded stone aggregate 20mm nominal size), cement plastered with CM 1:3(1 cement : 3 coarse sand) finishedwithafloatingcoatofneatcementandmaking necessary channels etc. complete. | | |
| 17.9.1 | For 100 to 200 mm dia pipes | Each | 353 |
| 17.9.2 | For 250 to 300 mm dia pipes | Each | 405 |
| 17.9.3 | For 350 to 450 mm dia pipes | Each | 661 |

| S.No. | Items | Unit | Rate (Rs.) |
|---------|---|----------|------------|
| 17.10 | Providing SCI (Sand Cast Iron) drop connection with SCI (Sand Cast Iron) drop pipe and bend encased alround with CC 1:5:10 (1 cement: 5 coarse sand: 10 graded stone aggregate 40 mm nominal size) including cutting holes and making good with brick work in cement mortar 1:5 (1 cement:5 fine sand) plastered with cement mortar 1:3 (1 cement: 3 fine sand) on inside walls including lead caulked joints and jointing SW pipes & SCI pipes with stiff cement mortar 1:1(1 cement: 1fine sand) including making required channel etc.complete. | | |
| 17.10.1 | 100 mm dia Sand cast iron drop connection | Each | 4745 |
| 17.10.2 | 150 mm dia Sand cast iron drop connection | Each | 7119 |
| 17.10.3 | Extra rate shall be payable for depths of drop more than 60 cm | | |
| (i) | 100 mm dia Sand cast iron drop connection | Per mtr. | 1424 |
| (ii) | 150 mm dia Sand cast iron drop connection | Per mtr. | 2135 |
| 75.11 | Road Gully Chambers ConstructionofBrickmasonryroadgullychambers with brick work in cement mortar 1:5 (1 cement: 5 fine sand) and 12mm thick plaster in cement mortar 1:3includingfoundationconcrete1:5:10(1cement :5 coarse sand :10 graded stone aggregate40mm nominal size)including excavation etc. complete. | | |
| 17.11.1 | Chamber 45x45x77.5cm with vertical grating 450x100 mm | each | 4376 |
| 17.11.2 | Chamber 50x45x60cm with horizontal grating 500x450 mm | each | 3878 |
| 17.11.3 | Chamber 110 x 50 x 77.5cm with horizontal 500 x 450 mm and vertical gratings 450x100 mm both. | each | 6779 |
| | REPAIRING | | |
| 17.12 | Dismantling of manhole including R.C.C./C.C. top slab, CI / pre cast RCC cover with frame including stacking of useful materials near the site and disposal of unserviceable materials into municipal dumps within 50 m lead | | |
| 17.12.1 | Manhole size 90x80 and 45 cmdeep | Each | 846 |
| 17.12.2 | Manhole size 90x80 and 60 cm deep | Each | 933 |
| 17.12.3 | Manhole size 120x90 and 90 cm deep | Each | 1398 |
| 17.12.4 | Manholes size 60x45 and 60 cm deep. | Each | 458 |
| 17.12.5 | Manholes size 60x60 and 90 cm deep. | Each | 664 |

| S.No. | Items | Unit | Rate (Rs.) |
|----------|---|-----------|------------|
| 17.12.6 | Extra for depth of manholes dismantling | | |
| (i) | Manhole size 90x80 cm, depth above 60 cm | Per Mtr. | 537 |
| (ii) | Manhole size 120x90cm, depth above 90 cm | Per Mtr. | 640 |
| (iii) | Manholes size 60x45 cm, depth above 60 cm | Per Mtr. | 377 |
| (iv) | Manholes size 60x60 cm, depth above 90 cm | Per Mtr. | 416 |
| 17.12.7 | Manhole 1.50 m dia circular and upto 2.65 m deep | Each | 2920 |
| 17.12.8 | Manhole 1.20 m dia circular, and upto 1.65 m deep | Each | 1818 |
| 17.12.9 | Manhole 0.90 m dia circular and upto 0.90 m deep | Each | 1098 |
| 17.12.10 | Extra for depth of manholes dismantling | | |
| (i) | Manhole 1.50 m dia circular, depth 2.65 to 4.25m | Per Mtr. | 1168 |
| (ii) | Manhole 1.50 m dia circular, depth 4.25 to 9.75m | Per Mtr. | 1607 |
| (iii) | Manhole 1.20 m dia circular, depth 1.65 to 2.30 m | Per Mtr. | 727 |
| (iv) | Manhole 0.90 m dia circular, depth 0.90 to 1.65m | Per Mtr. | 439 |
| 17.13 | Replacement of M.S. Foot rests in manhole including dismantling concrete block and fixing with 20x20x10 cm C.C. blocks of 1:3:6 (1 cement : 3 coarse sand : 6 graded stone aggregate 20mmnominalsize) | | |
| 17.13.1 | With 20mm square bar foot rest. | Each | 289 |
| 17.13.2 | With 20mm round bar foot rest. | Each | 259 |
| 17.14 | Pumping out to remove the sewers blockages by using suitable pump sets operated by generators , whole assembly mounted on two/four wheelstrailer /pickup van. Including diesel & labour charges etc. | Per Hours | 219 |
| 17.15 | Providing and fixing in position Cast Iron Manhole Covers and frame conforming to IS 1726. Allexposed edgesroundedendfinishedincementmortar etc. complete. | Kg. | 76 |
| 17.16 | Labour only for fixing in position Cast Iron Manhole Covers & frame conforming to IS:1726. | Kg | 5 |
| 17.17 | Providing & fixing of ISI marked pre cast reinforced cement concrete manhole cover including frame and transporting at site, cost of all material etc. | | |
| 17.17.1 | 500 mm dia extra heavy duty | Each | 2680 |

| S.No. | Items | Unit | Rate (Rs.) |
|--------------|---|-------------|-------------------|
| 17.17.2 | 560 mm dia extra heavy duty | Each | 2884 |
| 17.17.3 | 600 mm dia extra heavy duty | Each | 3290 |
| 17.17.4 | 500 mm dia heavy duty | Each | 2019 |
| 17.17.5 | 560 mm dia heavy duty | Each | 2375 |
| 17.17.6 | 600 mm dia heavy duty | Each | 2629 |
| 17.17.7 | 600 x 900 mm size extra heavy duty | Each | 4612 |
| 17.17.8 | 600 x 900 mm size heavy duty | Each | 4053 |
| 17.17.9 | 450 x 900 mm size heavy duty | Each | 3595 |
| 17.17.10 | 600 X 600 mm size extra heavy duty | Each | 3290 |
| 17.17.11 | 600 X 600 mm size heavy duty | Each | 2528 |
| 17.17.12 | 600 X 600 mm size mediumduty | Each | 2070 |
| 17.17.13 | 600 X 450 mm size heavy duty | Each | 2324 |
| 17.17.14 | 600 X 450 mm size medium duty | Each | 1969 |
| 17.17.15 | 450 X 450 mm size heavy duty | Each | 1765 |
| 17.17.16 | 450 X 450 mm size medium duty | Each | 1460 |
| 17.18 | Providing & fixing of ISI marked pre cast reinforced cement concrete manhole cover without frame and transporting at site, cost of all material etc. | | |
| 17.18.1 | 500 mm dia extra heavy duty | Each | 1657 |
| 17.18.2 | 560 mm dia extra heavy duty | Each | 1962 |
| 17.18.3 | 600 mm dia extra heavy duty | Each | 2267 |
| 17.18.4 | 500 mm dia heavy duty | Each | 1301 |
| 17.18.5 | 560 mm dia heavy duty | Each | 1657 |
| 17.18.6 | 600 mm dia heavy duty | Each | 2064 |
| 17.18.7 | 600 x 900 mm size extra heavy duty | Each | 3996 |
| 17.18.8 | 600 x 900 mm size heavy duty | Each | 3691 |
| 17.18.9 | 450 x 900 mm size heavy duty | Each | 2776 |
| 17.18.10 | 600 X 600 mm size extra heavy duty | Each | 2013 |
| 17.18.11 | 600 X 600 mm size heavy duty | Each | 1861 |
| 17.18.12 | 600 X 600 mm size mediumduty | Each | 1301 |
| 17.18.13 | 600 X 450 mm size heavy duty | Each | 1607 |
| 17.18.14 | 600 X 450 mm size medium duty | Each | 1068 |
| 17.18.15 | 450 X 450 mm size heavy duty | Each | 1098 |
| 17.18.16 | 450 X 450 mm size medium duty | Each | 895 |

CHAPTER XVIII

SURVEY
&
ALLIED CIVIL WORKS

CHAPTER XVIII

SURVEY & ALLIED CIVIL WORKS

1. SURVEY

1 **Applicable Codes:**

| IS Code No. | Title |
|--------------------|---|
| 273 - 1990 | Picks and beaters (Third revision) reaffirmed 2006 |
| 1492 - 1970 | Metric surveying chains (first revision, with 2 amendments) (Reaffirmed 1998) |
| 1759 - 1986 | Powrahs (Second revision) reaffirmed 2002 |
| 1779 - 1961 | 4 - Metre levelling staff, folding type (reaffirmed 2006) |
| 1842 - 1961 | Surveying chain pins (arrows) (reaffirmed 2006) |
| 1955 - 1961 | Prismatic compass, liquid (reaffirmed 2006) |
| 1957 - 1961 | Prismatic compass, non-liquid (reaffirmed 2006) |
| 2286 - 1963 | Ranging rods (reaffirmed 2006) |
| 2976 - 1964 | Optical theodolite (reaffirmed 2000) |
| 2988 - 1995 | Venire theodolite (with 3 amendments) (reaffirmed 2007) |
| 4080 - 1994 | Specification for Vertical staff gauges. (reaffirmed 2000) |
| 4590-1980 | Secondary level (First revision) (reaffirmed 2006) |
| 5497-1983 | Guide for topographical surveys for river valley projects (reaffirmed 2005) |
| 5510-1969 | Guide for soil survey for river valley projects (reaffirmed 2005) |
| 8330-2004 | Telescopic tripod for surveying instruments. |

- 2 Length of the survey will be measured along the lines on which particular type of survey is to be done. For example, for chain and compass survey, it would be the length along which the chaining and compassing is to be done. For levelling, it would be the total length of the lines along which levels are to be taken.
- 3 The rate are based on the following average daily progress that can be normally achieved under average conditions by one surveyparty:-

| Item | Head works |
|------|------------|
|------|------------|

| | |
|--------------------------------|------|
| Chain and compass survey | 2 km |
| Levelling (above 15m interval) | 2 km |

- 4 The labour strength of one survey party for chain and compass survey considered in (a) above is 12 mazdoors (3 for ranging, 1 for preparing pegs, 1 peg man, 2 chainmen, 1 compass man, 2 axe men for removing, obstacles, 1 waterman and 1 watchman for watch and ward of camp.)
- 5 For levelling (above 15m interval) the labour strength considered is mazdoors (2 chain and tape man, 1 staff man, 1 instrument man, 1 umbrella man, 1 waterman and 2 axe men to removing obstacles).
- 6 In very difficult terrain and special circumstances where the progress may be less special sanction for the rate should be obtained from the Superintending Engineer and the provisions for the same be made in the estimate.
- 7 To carry out survey for item No. 1.1 to 1.6 by Total Station Electronic Instrument the rates will be increased by 15% for Computer Engineer, other computer staff, computer stationary & plotting by computer as directed by Engineer-in-Charge & additional 10% for profit of the contractor.
- 8 **Measurement:**
The survey work shall be measured in Km/Hectare. No payment shall be made for surveying equipments.
9. **Ultra High Resolution UAV Mapping:-**
- 9.1 The surveying capacity of UAV should be of capacity more than 1000 Hect. per hour. In suitable flying conditions per day surveying coverage should be 2000 Hect.
- 9.2 The UAV should have accuracy range up to 25 cm X 25 cm to ensure meeting the surveying requirements as per need.
- 10 **Rates:**
- 10.1 The rates include charges for all tools & plants, survey equipments, other appliances etc. required for the work
- 10.2 The rates include provision and use of all covering etc. to protect the works from inclement weather etc.
- 11 **This USOR contains the rates of all the items without GST. No claims against GST shall be entertained at any level. GST shall be paid by the Agency/ Contractor directly to the concerning department. Howerer, All the estimates prepared on this USOR will include GST, as an extra amount as per prevailing rates on the sum of the estimate to arrive at the gross amount**

1. SURVEY

| Sr.No | Particulars of Items | Unit | Rates (in Rs.) |
|--------|--|-------|----------------|
| 18.1 | Chain and compass survey | Km | 1035 |
| 18.2 | Chain and theodolite survey | Km | 1035 |
| 18.3 | Theodolite work involving fixing of stones at every tenth chain, tangent apex and vertex point of final alignment | Km | 2071 |
| 18.4 | Fly levelling for fixing temporary bench marks : | | |
| 18.4.1 | Up to 15m interval | Km | 1035 |
| 18.4.2 | Above 15m interval | Km | 518 |
| 18.5 | Levelling Head works | | |
| 18.5.1 | Below 5m interval (for basin survey and dam seat survey) | Km | 1726 |
| 18.5.2 | 5 to 10m interval | Km | 1381 |
| 18.5.3 | more than 10 but up to 15m interval | Km | 1035 |
| 18.5.4 | Above 15m interval | Km | 690 |
| 18.6 | Double levelling for transfer of bench marks: | | |
| 18.6.1 | Up to 15m interval | Km | 4142 |
| 18.6.2 | Above 15m interval | Km | 2071 |
| 18.7 | Total Station Survey Detailed Geo referenced topographical mapping and development of graphic database for any selected area using digital state of art total station, automatic levels grid size 30 M x 30 M etc. as per site condition requirement and as directed by the Engineer-in-Charge including transfer of entire area data to computer system in different Geo referenced layer/themes using features of standard software. Compatible with urban area project system design software packages including supply of soft copies and 5 hard copies in appropriate scale complete. | | |
| 18.7.1 | Upto 5 Hect. | Hect. | 1496 |
| 18.7.2 | 5 Hect to 10 Hect. | Hect. | 998 |

| | | | |
|----------|---|-------|------|
| 18.7.3 | 10 Hect to 25 Hect. | Hect. | 748 |
| 18.7.4 | Above 25 Hect. | Hect. | 499 |
| 18.7.5 | Add extra in above for following grid levels in place of 30 mtr x 30 mtr grid size | | |
| 18.7.5.1 | Grid size 10mtr. x 10mtr. | Hect. | 200 |
| 18.7.5.2 | Grid size 20mtr. x 20mtr. | Hect. | 100 |
| 18.8 | Boring holes with auger for preparing trial pit for the investigation of the type of soil up to a depth of 3.5 m in any soil. | | |
| 18.8.1 | For 20 cm dia holes | Each | 137 |
| 18.8.2 | For 25 cm dia holes | Each | 168 |
| 18.8.3 | Add to or deduct from the rate for the trial holes of 3.5m depth if the trial holes are deeper or shallower | | |
| 18.8.3.1 | For 20 cm dia holes | Meter | 39 |
| 18.8.3.2 | For 25 cm dia holes | Meter | 48 |
| | | | |
| 18.9 | “Unmanned Aerial Vehicle (UAV)” – Detailed Geo Referenced topographical mapping with a surveying capacity of 1000 Hect. per hour of more and development of graphical database for any selected area using digital state of art UAV, automatic levels grid size 30M X 30M etc. as per site condition requirement and as directed by the Engineer-in-charge including transfer of entire area data set to computer system in different geo referenced layer/themes using features of standard photogrammetric software. Compatible with urban water/waste-water supply/drainage system design software packages including supply of soft copies and 5 hard copies in appropriate scale. | | |
| 18.9.1 | Up to 5 Hect | Hect | 1600 |
| 18.9.2 | 5 Hect. to 10 Hect | Hect | 1100 |
| 18.9.3 | 10 Hect. to 25 Hect | Hect | 850 |
| 18.9.4 | Above 25 Hect | Hect | 700 |
| 18.10 | Add extra in 18.9 the above for following grid levels in place of 30mx30m grid size:- | | |
| 18.10.1 | Grid Size 25 CM X 25 CM | Hect | 400 |
| 18.10.2 | Grid Size 50 CM X 50 CM | Hect | 350 |
| 18.10.3 | Grid Size 1 M X 1 M | Hect | 300 |
| 18.10.4 | Grid Size 5 M X 5 M | Hect | 250 |
| 18.10.5 | Grid Size 10 M X 10 M | Hect | 200 |

| | | | |
|---------|--|------|-------|
| 18.10.6 | Grid Size 20 M X 20 M | Hect | 100 |
| 18.11 | Survey and Leveling Head works by UAV - Detailed Geo Referenced topographical mapping (covering 15 m with on either side of center line) with a minimum surveying capacity of 10 km per hour and development of graphical database for any selected area using digital state of art UAV, automatic levels with 15 m interval as per site condition requirement and as directed by the Engineer-in-charge including transfer of entire area data set to computer system in different geo referenced layer/themes using features of standard photogrammetric software. Compatible with urban water/waste-water supply/drainage system design software packages including supply of soft copies and 5 hard copies in appropriate scale. | | |
| 18.11.1 | Up to 5 km | Km | 12000 |
| | 5 Km to 10 Km | Km | 9500 |
| | 10 Km to 25 Km | Km | 8500 |
| | Above 25 Km | Km | 7500 |
| 18.12 | Add extra in above for following levels in place of 15 m interval | | |
| 18.12.1 | 25cm to 50cm interval | Km | 1600 |
| 18.12.2 | 50cm to 1m interval | Km | 1400 |
| 18.12.3 | 1m to 3 m interval | Km | 1200 |
| 18.12.4 | 3m to 5 m interval | Km | 1000 |
| 18.12.5 | 5m to 10 m interval | Km | 800 |
| 18.12.6 | 10m to 15 m interval | Km | 700 |

2. ALLIED CIVIL WORKS

Excavation and Preparation of Trench

1. The rates for various items of civil works given in this chapter shall be applicable for the civil works connected with laying and jointing of water supply and sewerage pipeline works only. These rates shall not be applicable for the items of civil works for which the rates has already given in the relevant chapters.
2. The trenches shall run in perfectly straight line between points or manholes, as shown on the approved drawings.

3. The excavation of the trench shall be commenced at the downstream end of the sewer and be continued up the gradient.
4. The trench shall be excavated only so far in advance of pipe laying as specified by the Engineer in Charge. It shall usually be so regulated as to enable the excavation to be completed about one day in advance of pipe laying.
5. The trench shall be so shored and drained that the workmen may work there in safely and efficiently.
6. The trench shall be kept free from water. Excavation below water table shall be done after dewatering trenches. The discharge of the trench dewatering pumps shall be conveyed either to discharge channels or to natural drains.
7. The excavation shall be carried out with manual labour or with suitable mechanical equipment as approved by the Engineer in charge.
8. When the pipeline is under a roadway, a minimum cover of 100 cm is recommended for adoption but it may be modified to suit local conditions and in case of A.C. pipe a cover of at least 1.25 m is provided. Where the pipe line or drains crosses the road, the road crossing shall be excavated half at a time, the 2nd half being, commenced after the pipes have been laid in the 1st half and the trench refilled. Necessary safety measures for traffic as directed shall be adopted. All water mains; cables and any other such services etc. met within the course of excavation shall be carefully protected and supported. Care shall be taken not to disturb the electrical and communicator cable met with during course of excavation, removal of which if necessary shall be arranged by the engineer in charge.
9. Trench shall be of sufficient width to provide a free working space on either side of pipe. At the bottom between the faces, it shall be such as to provide not less than 200mm clearance on either side of pipe. Additional width shall have to be provided at position of sockets, flanges, D.Joints for jointing. Depth of pit at such places shall also be sufficient to permit finishing of joints.
10. In obtaining the formation of the bottom of the trenches in case of sewer line, the usual method of using sight rails and boning rods shall be adopted during the whole of the process. The sight rails shall be fixed at all changes of direction or gradient and at suitable intervals, which may not be more than 15 meters apart, before excavation is started. The centre line shall be marked on each horizontal rail, which is fixed at true level.
11. The excavation shall be boned in at least once in every 2 meters, the foot of the boning rod being set on a block of wood of the exact thickness of the material of the pipes.
12. Except where special foundations are to be provided, the trench shall be

excavated in accordance with one of the following alternatives as may be considered appropriate by the Engineer incharge.

- (a) The trench shall be excavated to the exact gradient specified so that no making of the sub grade by back filling is required and the concrete bed, where required, may be prepared with greatest ease giving a uniform and continuous bearing and support for the pipe
 - (b) When the bottom of the trench at the specified gradient is found to be unstable or to include ashes and cinders, all types of refuse, vegetable or other organic material, or large pieces or fragments of inorganic material, they shall be removed to the satisfaction of the Engineer in charge. Before laying the concrete bed, where necessary, the specific gradient shall be attained by back filling with an approved material in compacted layers of 8 cm. The layers shall then be tamped as directed by the Engineer in Charge.
 - (c) The bed of the trench, if in soft or made up earth, shall be well watered and rammed before laying the pipes and the depression. If any shall be properly filled with approved earth and consolidated in 20 cm layer.
 - (d) The bed of the trench, if in B.C. Soil, shall be excavated 20cm more than the normal depth and then filled up by moorum or granular material.
13. If the sides of the trench are not vertical the toes of the side slopes shall end at the top of the pipe and practically, vertical sided trench shall be dug from these down to the subgrade.

14. The bottom of the trench shall be properly trimmed off to present a plain surface and all irregularities shall be levelled.
15. Where rock and large stone or boulders are encountered the trench shall be trimmed to a depth of at least 8 cm below the level at which the bottom of the barrel of the pipe is to be laid and the trench brought back to the required grade by filling with selected fine sand broken stone (passing sieve of 12.5mm aperture size) and compacted so as to provide a smooth bedding for the pipes.
16. After the Excavation of the trench is completed hollows shall be cut at required position to receive the socket of the pipe and these hollows shall be of sufficient depth to ensure that the bearer of the pipe shall rest throughout their entire length on the solid ground and that sufficient space left for joining the under side of the pipe joint. These socket holds shall be refilled with sand after joining the pipe.
17. Where the bottom of the trench at sub grade is found to consist of material which is unstable to such a degree that, in the opinion of the Engineer in charge, it cannot be removed and replaced with an approved material thoroughly compacted in place to support the pipe properly, a suitable foundation for the consist of piling, timbers or other materials, in accordance with plan prepared by the Engineer in Charge shall be constructed.
18. Trench excavation in rock in inhabited areas should be done by hammering and chiselling or other appropriate mechanical means but not by blasting.
19. Excavation for trenches in rock by blasting shall be permitted only in open areas, with the written permission of the competent authority, after the Engineer in charge has satisfied himself that there is no danger to persons or property if blasting is done in that area. All necessary licenses etc shall be the responsibility of the contractor.
20. Proper precautions shall be taken for the protection of persons or property during blasting by the contractor after obtaining necessary permission for blasting from the concerned authorities..
21. The hours of blasting shall be fixed by the Engineer in charge in consultation with the concerned local authorities.
22. The procedure of blasting shall conform to the requirements of local administration controlling authorities.
23. Open cut deep trenches in bad ground shall be sheeted and braced as required by local municipal regulations and as may be necessary to protect life, property or the work. Payment shall be regulated as per terms of the agreement.

24. When close sheeting is required, it shall be so driven as to prevent adjacent soil from entering the trench either below or through such sheeting for which no extra payment shall be made.
25. Engineer in charge shall have the right to order the sheeting to be driven to the full depth of the trench or to such additional depths as may be required for the protection of the work, as per manual on water supply and sewage and sewage treatment (1993 Second edition) for which no extra payment shall be made.
26. Where the soil in the lower limits of a trench has the necessary stability, the Engineer in charge at his discretion, may permit stopping of the driving of sheeting at some designated elevation above the trench bottom for which no extra payment shall be made.
27. Sheeting done in trenches near heavy or important buildings shall be left in ground, if any settlement of the buildings is anticipated as per direction of Engineer in Charge and for which no extra payment shall be made.
28. Sheeting and bracing which have been ordered left in place should be removed for a distance of 90 cm. below the established street level or the existing surface of the street whichever is lower for which no extra payment shall be made.
29. Trench bracing, except that which has been left in place may be removed after the back filling has been completed or has been brought up to such an elevation as to permit its safe removal for which no extra payment shall be made.
30. Sheeting and bracing may be removed before filling the trench, but only in such manner as will ensure the adequate protection of the completed work and adjacent structures.
31. All surface materials which in the opinion of the Engineer in charge, are suitable for reuse in restoring the surface, shall be kept separate from the general excavation material as directed by the Engineer in charge.
32. The excavated material shall be not placed within one meter or half of the depth of the trench, whichever is greater, from the edge of the trench. The excavated material shall be separated and stacked so that in refilling it may be re laid and compacted in the order to the satisfaction of the engineer in charge.
33. (a) If the hard rock is found throughout the depth, then the trench after pipe laying should be filled up with good excavated earth except B.C. soil, if available within 50m lead, on either side of pipe and upto 30cm above

the pipe and remaining depth shall be filled up with excavated hard rock. The balance hard rock shall be compulsorily issued to the contractor at

such issue rate, which are specified in the contract agreement after maintaining proper M.A.S. account. If good soil and hard rock in excavation is obtained, then suitable action as explained above shall be taken accordingly.

If hard rock in excavation is obtained throughout the length and no good soil is obtained on either side within 50m of excavation then it shall be filled up by moorum and payment shall be made as per item No. 16.11. In this case overall rock shall be compulsorily issued at the rate of Rs 170 per cum to be specified in the contract agreement after maintaining proper M.A.S. account. Payment shall be regulated as per terms of agreement at appropriate rate.

- (b) In case of B.C. soil the side of pipe and filling above 30 cm of pipe shall be done by moorum and balance depth shall be filled up by excavated B.C. Soil.
34. Hydrants under pressure, surface boxes, fire or other utility controls shall be left unobstructed and accessible until the work is completed.
 35. Gutters shall be kept clear or other satisfactory provisions made for street drainage and natural watercourses shall not be obstructed.
 36. To protect person from injury and to avoid danger to property, adequate barricades, construction signs, torches, red lanterns and guards as required shall be placed and maintained during the progress of the construction work and until it is safe for traffic to use the road way.
 37. All materials, piles, equipment and pipe which may serve as obstructions to traffic shall be enclosed by fences or barricade and shall be protected by proper lights when the visibility is poor.
 38. The rules and regulations or the local authority regarding safety provisions shall be observed.
 39. The work shall be carried in such a manner, which will cause the least interruption to traffic, and the road or street may be closed in such a manner that it causes the least interruption to the traffic.
 40. Where it is necessary for traffic to cross open trenches, suitable cross over planks shall be provided.
 41. Suitable signs indicating that a street is closed shall be placed and necessary detour signs for the proper maintenance of traffic shall be provided.
 42. Temporary support, adequate protection and maintenance of all underground and surface structure, drains, sewers and other obstructions encountered in the progress of the work shall be provided under the direction of the Engineer in charge.

- 43 The structure, which may have to be disturbed, shall be restored upon completion of the work.
- 44 Trees, shrubbery, fences, poles and all other property and surface structures shall be protected unless their removal is shown on the drawing or authorised by the Engineer in charge.
- 45 Root of trees within a distance of about 0.5m from the site of the pipeline shall be removed or killed for which no extra payment shall be made.
- 46 No valve or other control of the existing serving shall be operated without the permission of the Engineer in charge.
- 47 The rates include the element of hire and running charges of all types of plants, machinery & equipment, required to complete the work, unless specified otherwise.
- 48 The rates also include the element of testing of samples of various materials brought by contractor for use on the work, as well as other necessary test for item of work as stipulated in the specifications.
- 49 The work should not be accepted in any case if the contractor fails to observe the instruction of department regarding testing of material.
- 50 Before making any payment, it will be responsibility of the officer making payment to assure that all tests are as per prescribed frequency have been carried out and found as per requirement.
- 51 The contractor shall have to provide bound ruled register named as Site Order Book it shall be kept in the charge of Deptt. Supervisory staff inspecting officer will enter their remarks in this book which will be noted by contractor or his authorized representative for compliance and report.
- As mentioned in para 12.9, the width of excavation shall be as per specification given in the relevant I.S. Specification. The bottom width, which shall be kept as minimum required for the work as per ISS and if the depth of the trench is more the top width shall depend on the angle of repose for a particular type of soil where the pipe line is to be laid.
- 52 The rate for cutting and making in the same condition include all lead of the material and also required work and equipment to complete the work as per specification and as directed by Engineer in charge.
- 53 The contractor shall be fully responsible to carry out the work in a most safe way and he shall be fully liable and responsible for any accidents due to any reason, during the currency of the contract.

II. SPECIFICATION FOR CIVILWORKS

All the civil works shall be done strictly as per relevant I.S. Specifications and all the materials shall also confirm to the relevant I.S. Specifications. All the necessary tests of material and work shall be carried out for each work. Where applicable, the contractor shall also submit manufacturer's test certificates for materials to the Engineer in Charge.

Materials Specification

(a) **Cement:**

Cement to be used in the work shall be any of the following types with prior approval of Engineer-in-charge.

Ordinary Portland cement 43 or 53 grade conforming to IS: 8112-1489 or P.P.C. conforming to IS : 1489 bearing ISI mark.

(b) **Coarse Aggregate:**

Coarse aggregate consist of clear, hard, strong, dense, non-porous and durable pieces of crushed stone. They shall not consist pieces of elongated particles salt, alkali, vegetable matter or other deleterious material.

All coarse aggregate shall confirm to IS:383& tests for conformity shall be carried out as per IS:2386 Part I to VIII. The maximum value of flakiness index for coarse aggregate shall not exceed 35%. The coarse aggregate shall satisfy the following requirement of grading.

| I.S.Sieve | Percentage by Weight Passing the Sieve | | |
|-----------|--|--------|--------|
| | 40mm | 20mm | 12.5mm |
| 63mm | 100 | -- | -- |
| 40mm | 95-100 | 100 | -- |
| 20mm | 30-70 | 95-100 | 100 |
| 12.5mm | -- | -- | 90-100 |
| 10mm | 10-35 | 25-55 | 40-85 |
| 4.75mm | 0-5 | 0-10 | 0-10 |

(c) **Sand / Fine Aggregate:**

Sand shall not contain dust, lumps and soft or flaky materials fine aggregate having positive alkali silica reaction shall not be used. All fine aggregate shall confirm to IS: 383. The fineness modulus of fine aggregate shall neither be less than 2.0 nor greater than 3.5. Sand to be used in work shall confirm to IS:1542-1960 for plaster and IS: 166-1965 for masonry work. Clay content should not be more than permissible limit.

(d) **Water:**

Water used for mixing and curing shall be clean and free from injurious amounts of oils, acids, salts, sugar, organic material or other substances that may be deleterious to concrete potable water in generally consider satisfactory for mixing and curing of concrete.

- (e) **Steel:**
For R.C.C. works steel to be used shall confirm to IS:1786. All steel be procured from original producer and no re-rolled steel shall be used in the work. Only new steel shall be delivered to site. Brittle burnt, defective, cracked bar shall be discarded.
- (f) **Concrete:**
Normally concrete shall be mixed either in a concrete mixer or in a batching & mixing plant. Hand mixing is prohibited and under unavoidable circumstances it should be done only with the prior permission of Engineer-in-charge. Mixing shall be continued till materials are uniformly distributed and a uniform colour of entire mass is obtained and each particle of aggregate shows coating of cement. In no case mixing shall be done for less than 2 minutes. Concrete shall be transported and placed as near as practicable to its final position within 30 minutes of its discharge from the mixer.
- (i) Structural steel shall be of tested, standard quality confirming to IS:226-69 and commercial quality shall confirm to IS:1977-69.
- (ii) Steel work riveted or bolted shall confirm to IS:1148-1968 and IS:800-1962.
- (iii) Welding of steel shall be electric arc welding as per IS:816-1956 and shall be on the lines given in IS: 800-1962.
- (iv) Rolled steel section for fabrication of steel shall confirm to IS:7452-1974.
- (v) Rates of steel angle includes all forgoing, reducing to required size, shape and figure, drilling, tapping, punching etc. and every description of workmanship that may be necessary to fabricate, finish, erect and fix in position in perfect manner.
- (g) **Bricks:**
- (i) The brick work shall be carried out as per relevant I.S. Specifications and the drawing, specification and direction by the Engineer-in-charge.
- (ii) Burnt clay bricks shall confirm to the requirement of IS:1077. They shall be free from cracks and flaws and nodules of free lime. The brick shall have smooth rectangular faces with sharp edges and corners.
- (iii) Cement mortar for work shall be as per the relevant specification.
- (iv) All bricks shall be thoroughly soaked in tank filled with water for minimum period one hour prior to being laid such soaked bricks shall be stacked on a clean place where they are not contaminated with earth / dirt etc.
- (v) The thickness of joint shall not exceed 10mm
- (vi) The Brick work shall be built in uniform layers.
- (vii) Brick work shall be done true to plumb in specified manner. All courses shall be laid truly horizontal and vertical joints shall be truly vertical.
- (viii) In case of vertical or inclined joints proper bond between old and new masonry has to be ensured by interlocking the bricks.

- (ix) Green work / fresh work shall be protected from rain by suitable covering and shall be kept constantly moist on all faces for minimum of 7days.
- (h) **MORTAR:**
The mortar mixing shall preferably be done in mechanical mixer operated manually or by power. Hand mixing can be restored to as long as uniform density of the mix and its strength are assured subject to prior approval of Engineer-in-charge. Hand mixing operation, if permitted, carried out on clean water tight platform when cement and sand shall be first mixed dry in required proportion several times till the mixture is of uniform. Minimum quantity of water shall be added to bring the mortar to the consistency of still paste. Mortar shall be mixed only in such quantity as required for immediate use. The mortar normally be considered to use within 30 minutes. Mortar after 30 minutes remains unused shall be rejected and removed from site.
- (i) **PLASTER:**
Plastering shall be done where shown on as per drawing. Plastering shall be started from top and worked down. Wooden screeds 75mm wide and of the thickness of the plaster shall be fixed vertically 2.5 to 4 mt. apart to act as gauge and guide in applying plaster. The mortar shall be laid on the wall between the screeds using the plasters float and pressing the mortar so that packed joints are properly filled. The plaster shall there be finished off with a wooden straight edge reaching across the screeds. The straight edge shall be worked on the screeds with small upward and side ways motion 50mm to 75mm at a time. Finally, the surface shall be finished off with a plasters wooden float metal floats shall not beused.
Curing shall be commenced as soon as mortar used for finishing has hardened sufficiently not be damaged during curing. It shall be kept wet fora period of at least 7days.
- (j) **FORM WORK:**
- (i) Form work shall include all temporary form for forming concrete of shape with all props, staging and centring required forsupport.
- (ii) All material shall confirm to relevant I.S.specifications
- (iii) Form work shall be constructed with metal or timber, for metal all bolts should be countersunk.
- (iv) The form work should be robust and strong and joint shall be leak proof, staging must have cross bracing and diagonal bracing in bothdirection.
- (v) The rates include provision of gradient in form work for terrace roof and gradient shall be provided necessarily for water drained out quickly and effectively. Concrete shall not be freely dropped into place from height exceeding 1.50 mt. And it shall be compacted in its final position within 30 minutes of its discharge from mixer. It shall be compacted thoroughly by vibration or other means during placing so as to produce a dense homogenous void free mass having required surfacefinish.

This USOR contains the rates of all the items without GST. No claims against GST shall be entertained at any level. GST shall be paid by the Agency/ Contractor directly to the concerning department. However, All the estimates prepared on this USOR will include GST, as an extra amount as per prevailing rates on the sum of the estimate to arrive at the gross amount.

2. ALLIED CIVIL WORKS

| S.No. | Items | Unit | Rates in Rs. |
|-------------------|--|------------|--------------|
| EXCAVATION | | | |
| 18.13 | Surface dressing of the ground including removing vegetation and in - equalities not exceeding 15 cm deep and disposal of rubbish, lead up to 50 m and lift up to 1.5 m. All kind of soil | 100 Sqm | 1055 |
| 18.13.1 | Clearing jungle including uprooting of rank vegetation, grass, brush wood, trees and saplings of girth up to 30 cm measured at a height of 1 m above ground level and removal of rubbish up to a distance of 50 m outside the Periphery of the area cleared. | 100 Sqm | 544 |
| 18.13.2 | Clearing grass and removal of rubbish up to a distance of 50 m outside the periphery of the area cleared. | 100 Sqm | 279 |
| 18.14 | Installation of HDPE pipe by Horizontal Direction Drilling Method including preparing and setting up the plant and equipment, making string of new pipe material, installing new pipe string and making the system ready for commissioning by HDD operation including drilling, stringing, reaming and pulling back the new pipe on the designed bore path alignment, proper disposal of drilling fluid, as per code of practice for horizontal direction drilling technique suiting indian conditions. Required pipes/ specials and other civil work shall be paid separately-in all types of soils. (This item shall be executed only after prior permission of Superintending Engineer) | | |
| | HDPE pipe of any class-90 mm outer dia | Meter | 459 |
| | HDPE pipe of any class-110 mm outer dia | Meter | 500 |
| 18.15 | Earth work in excavation for pipe trench in ordinary soil areas including dressing, watering, ramming and disposal of excavated earth lead up to 50m and lift up to 1.5m, disposal earth to be levelled, neatly dressed. | Cum | 161 |

| S.No. | Items | Unit | Rates in Rs. |
|---------|--|------|--------------|
| 18.16 | Earth work in excavation for pipe trench in Hard soil areas including dressing, watering, ramming and disposal of excavated earth lead up to 50m and lift up to 1.5m, disposal earth to be levelled, neatly dressed. | cum | 213 |
| 18.17 | Earth work in excavation for pipe trench in Laterite soil areas including dressing, watering, ramming and disposal of excavated earth lead up to 50m and lift up to 1.5m, disposal earth to be levelled, neatly dressed. | Cum | 308 |
| 18.18 | For muddy area, extra rate for item No. 18.15 (extra percentage rate is applicable in respect of each item but limited to quantities of work executed in these difficult conditions). | Cum | 20 % |
| 18.19 | Earth work in excavation for pipe trench in all kinds of rocks in areas including dressing, stacking of useful material and disposal of unserviceable material up to lead up to 50m and lift up to 1.5m. | | |
| 18.19.1 | Soft rock with or without blasting or bituminous pavement / cement concrete road. | Cum | 373 |
| 18.19.2 | Hard rock (requiring blasting.) | Cum | 458 |
| 18.19.3 | Hard rock requiring chiseling / where blasting is prohibited. | Cum | 532 |
| 18.20 | Extra for every additional lift of 1.5m or part there of | | |
| 18.20.1 | All kind of soils (over item No. 18.15, 18.16 and 18.17) | Cum | 54 |
| 18.20.2 | Ordinary soft and Hard rock (over item No. 18.19.1, 18.19.2 and 18.19.3) | Cum | 96 |
| 18.19 | Extra for every additional lead up to 50 m or part thereof over item 18.15 to 18.19.3 | cum | 56 |
| 18.20 | Earthwork in excavation of foundation for structures as per drawing and technical specification including setting out, construction of shoring and bracing, removal of stumps and other deleterious matel, dressing of sites and bottom and back filling with approved materials etc. and as per relavent codes in practice. | | |
| | Ordinary soil | | |
| 18.20.1 | Up to 3m depth | cum | 165 |
| 18.20.2 | 3m to 6m depth | cum | 201 |

| S.No. | Items | Unit | Rates in Rs. |
|---------|--|------|--------------|
| 18.21 | Pumping out water caused by springs, tides or river seepage, broken water mains or drains or well or the like. | KL | 57 |
| 18.22 | Filling available excavated earth in trenches, plinth sides of foundation in layers not exceeding 20cm. in depth including consolidation of each layer by ramming watering, lead up to 50m and lift up to 1.5m in all kinds of soils | cum | 66 |
| 18.23 | Filling available excavated earth in trenches, lead up to 50m and lift up to 1.5m in all kind of soil excluding Watering and ramming. | Cum | 50 |
| 18.24 | Supply & Filling moorum/river sand for pipe bedding or over the pipe (including supply) | cum | 693 |
| 18.25 | Supply & Filling crusher stone dust for pipe bedding or over the pipe (including supply of crusher stone dust.) | cum | 897 |
| | DISMANTLING & DEMOLISHING | | |
| 18.26 | Demolishing Brick work in lime or cement mortar in any mix including stacking of serviceable material and disposal of unserviceable material with in 50 meter lead as per direction of engineer-in-charge. (In cement mortar) | Cum | 640 |
| 18.27 | Demolishing stone rubble masonry manually/mechanical means including stacking of serviceable material and disposal of unserviceable material with in 50 meter lead as per direction of engineer-in-charge.(In lime mortar) | Cum | 360 |
| 18.28 | Demolishing stone rubble masonry manually/mechanical means including stacking of serviceable material and disposal of unserviceable material with in 50 meter lead as per direction of engineer-in-charge.(In cement mortar) | Cum | 763 |
| 18.29 | Demolishing cement concrete manually / bymechanical means including disposal of material within 50 m lead as per direction of engineer-in-charge. | | |
| 18.29.1 | Nominal concrete 1:3:6 or richer mix (i/c equivalent design mix) | Cum | 758 |
| 18.29.2 | Nominal concrete 1:4:8 or Leaner mix (i/c equivalent design mix) | Cum | 467 |

| S.No. | Items | Unit | Rates in Rs. |
|---------|---|------|--------------|
| 18.29.3 | Dismantling of Cement Concrete Pavment by mechanical means using pneumatic tools, cutter breaking to pieces not exceeding 0.02 cum in volume and stock piling at designated locations and disposal of dismantled materials up to a lead of 1000 metres, stacking serviceable and unserviceable materials separately | Cum | 984 |
| 18.30 | Demolishing R.C.C. work manually / by mechanical means including stacking of steel bars and disposal of unserviceable material within 50 m lead as per direction of engineer-in- charge. | Cum | 1105 |
| 18.31 | Dismantling old plaster or skirting raking out joints and cleaning the surface for plaster including disposal of rubbish to the dumping within 50 meters lead. | Sqm | 14 |
| 18.32 | Dismantling stone slab flooring laid in cement mortar including stacking of serviceable material and disposal of unserviceable material within 50 m lead | Sqm | 83 |
| 18.33 | Dismantling kharanja of any thickness in cement mortar of any mix | Sqm | 64 |
| | REPAIRS TO BUILDING/ ROAD WORK | | |
| 18.34 | Providing& Fixing of stone slab 30 mm thick in cement mortar 1:6 (1 cement 6 sand) | Sqm | 150 |
| 18.35 | Labour only for Fixing of stone slab 30 mm thick in cement mortar 1:6 (1 cement 6 sand) | Sqm | 69 |
| 18.36 | Providing & FixingofKharanja of any thicknessin C.M. 1:6 (1 cement 6 sand) | Sqm. | 506 |
| 18.37 | Labour only for fixing of Kharanja of any thickness. | Sqm | 134 |
| 18.38 | Cutting of Water bound macadam road and making good the same including supply of extra quantities of materials i.e. aggregate, moorum screening and labour required including compaction inlayer by appropriatemethods. | Cum | 1063 |
| 18.39 | Cutting of Bituminous road and making good the same including supply of extra quantities of materials i.e. aggregate, moorum screening and labour requiredincluding compaction inlayer by appropriate methods. | Cum | 2157 |
| | CEMENT CONCRETE | | |

| S.No. | Items | Unit | Rates in Rs. |
|-----------|--|------|--------------|
| 18.40 | Providing and laying mechanically mixed cement concrete with crushed stone aggregate excluding centering and shuttering (with 40mm nominal size graded stone aggregate) | | |
| 18.40.1 | In foundation and plinth | | |
| 18.40.1.1 | 1:5:10 (M-5) | cum | 3530 |
| 18.40.1.2 | 1:4:8 (M-7.5) | cum | 3744 |
| 18.40.1.3 | 1:3:6 (M-10) | cum | 4032 |
| 18.40.1.4 | 1:2:4 (M-15) | cum | 4739 |
| 18.40.2 | In walls & Superstructure up to 4 mt. height above plinth (with 40mm nominal graded metal) | | 0 |
| 18.40.2.1 | 1:3:6(M-10) | cum | 4106 |
| 18.40.2.2 | 1:2:4(M-15) | cum | 4812 |
| 18.41 | Providing & laying mechanically mixed cement concrete 20mm nominal size graded crushed stone excluding cost of centering & shuttering. | | |
| 18.41.1 | In Plinth & foundation | | |
| 18.41.1.1 | 1:3:6 (M-10) | cum | 4182 |
| 18.41.1.2 | 1:2:4 (M-15) | cum | 4774 |
| 18.41.1.3 | 1:1 ¹ / ₂ :3 (M-20) | cum | 5248 |
| 18.41.1.4 | 1:1:2(M-25) | cum | 6492 |
| 18.41.2 | In walls and superstructure up to 4 mt. height above plinth (with 20mm nominal graded metal) | | |
| 18.41.2.1 | 1:3:6 (M-10) | Cum | 4257 |
| 18.41.2.2 | 1:2:4 (M-15) | Cum | 4849 |
| 18.41.2.3 | 1:1 ¹ / ₂ :3 (M-20) | Cum | 5323 |
| 18.41.2.4 | 1:1:2(M-25) | Cum | 6566 |
| | REINFORCED CEMENT CONCRETE | | |
| 18.42 | Providing & laying mechanically mixed R.C.C. excluding centering & shuttering and reinforcement in foundation/plinth (20mm graded metal) | | |

| S.No. | Items | Unit | Rates in Rs. |
|---------|--|------|--------------|
| 18.42.1 | 1: 1 ¹ / ₂ :3 (M 20) | cum | 4831 |
| 18.42.2 | 1:1:2 (M 25) | cum | 6074 |
| 18.42.3 | 1:0.75:1.5 (M 30) | cum | 6400 |
| 18.43 | Providing & laying mechanically mixed R.C.C. excluding centering & shuttering and reinforcement in superstructure up to 4 mtr. Height above plinth level (20mm graded metal) | | |
| 18.43.1 | 1: 1 ¹ / ₂ :3 (M 20) | cum | 4867 |
| 18.43.2 | 1:1:2 (M 25) | cum | 6111 |
| 18.43.3 | 1:0.75:1.5 (M 30) | cum | 6437 |
| | STEEL | | |
| 18.44 | Providing and placing in position cold twisted steel and hot rolled deformed steel reinforcement for R.C.C. work i/c cutting, bending, binding etc. complete i/c cost of binding wire and wastage. | Kg | 56 |
| 18.45 | Structural steel work in single section, fixed with or without connecting plate, including cutting, hoisting fixing in position and applying a priming coat of approved steel primer all complete. | Kg | 60 |
| 18.46 | Structural steel work riveted, bolted or welded in built-up section trusses and framed work i/c cutting/hoisting /fixing in position and applying a priming coat of approved steel primer all complete. | Kg | 77 |
| 18.47 | Steel work in welded built-up section/ framed work, including cutting hoisting, fixing in position and applying a priming coat of approved steel primer using structural steel etc. as required. | | |
| 18.47.1 | In stringers treads landings etc. of stair cases including use of chequered plate wherever required all complete. | Kg | 80 |
| 18.47.2 | In gratings, frames, guard bar, ladder ,railings, brackets, gates and similar works | Kg | 99 |
| 18.48 | Providing and fixing 1mm thick M.S. sheet door shutters with frame and diagonal braces of 40x40x6 mm angle iron, 3mm M.S. gusset plates at the junctions and corners i/c all necessary fittings complete including applying a priming coat of approved steel primer. with diagonal braces and central cross piece of M.S. angle / flats as required. | Sqm | 2941 |

| S.No. | Items | Unit | Rates in Rs. |
|---------|---|------|--------------|
| | CEMENT MORTAR | | |
| 18.49 | Cement Mortar 1:3 (1 Cement : 3 sand) | Cum | 4749 |
| 18.50 | Cement Mortar 1:4 (1 Cement : 4 sand) | Cum | 3983 |
| 18.51 | Cement Mortar 1:5 (1 Cement : 5 sand) | Cum | 3509 |
| 18.52 | Cement Mortar 1:6 (1 Cement : 6 sand) | Cum | 3213 |
| 18.53 | Cement Mortar 1:8 (1 Cement : 8 sand) | Cum | 3114 |
| | BRICK WORK | | |
| 18.54 | Brick work with well burnt chimney bricks having crushing strength not less than 25 kg/cm ² and water absorption not more than 20 % in foundation & plinth i/c curing etc. complete. | | |
| 18.54.1 | In Cement Mortar 1:3 | Cum | 6085 |
| 18.54.2 | In Cement Mortar 1:4 | Cum | 5799 |
| 18.54.3 | In Cement Mortar 1:5 | Cum | 5681 |
| 18.54.4 | In Cement Mortar 1:6 | Cum | 5607 |
| 18.55 | Brick work with well burnt chimney bricks having crushing strength not less than 25 kg/cm ² and water absorption not more than 20% in super structure above plinth level and up to floor two level i/c form work & curing etc. complete. | | |
| 18.55.1 | In Cement Mortar 1:3 | Cum | 6629 |
| 18.55.2 | In Cement Mortar 1:4 | Cum | 6105 |
| 18.55.3 | In Cement Mortar 1:5 | Cum | 5977 |
| 18.55.4 | In Cement Mortar 1:6 | Cum | 5891 |
| 18.56 | Extra rate for Brick work in superstructure above floor two level for each additional floor or part thereof respective item. | Cum | 162 |
| 18.57 | Half brick masonry with well burnt chimney bricks crushing strength not less than 25kg/cm ² and water absorption not more than 20% is superstructure above plinth level and up to floor two level. | | |
| 18.57.1 | Cement mortar 1:3 | Sqm | 765 |

| S.No. | Items | Unit | Rates in Rs. |
|---------|--|------|--------------|
| 18.57.2 | Cement mortar 1:4 | Sqm | 702 |
| 18.58 | Brick work with open Bhatta bricks having crushing strength not less than 20 kg/cm² and water absorption not more than 25% in foundation & plinth i/c curing etc.complete. | | |
| 18.58.1 | In Cement Mortar 1:3 | Cum | 5791 |
| 18.58.2 | In Cement Mortar 1:4 | Cum | 5583 |
| 18.58.3 | In Cement Mortar 1:5 | Cum | 5454 |
| 18.58.4 | In Cement Mortar 1:6 | Cum | 5376 |
| 18.59 | Brick work with open Bhatta bricks having crushing strength not less than 20 kg/cm² and water absorption not more than 25% in super structure above plinth level and up to floor two level i/c form work & curing etc. complete. | | |
| 18.59.1 | In Cement Mortar 1:3 | Cum | 6502 |
| 18.59.2 | In Cement Mortar 1:4 | Cum | 5809 |
| 18.59.3 | In Cement Mortar 1:5 | Cum | 5681 |
| 18.59.4 | In Cement Mortar 1:6 | Cum | 5601 |
| | PLASTER | | |
| 18.60 | 12mm thick cement plaster in single coat including finishing even, smooth and curing complete. | | |
| 18.60.1 | 1:3(Cement 1: Sand 3) | Sqm | 159 |
| 18.60.2 | 1:4(Cement 1: Sand 4) | Sqm | 148 |
| 18.60.3 | 1:5(Cement 1: Sand 5) | Sqm | 141 |
| 18.60.4 | 1:6(Cement 1: Sand 6) | Sqm | 137 |
| 18.61 | 15mm thick cement plaster in single coat i/c finished even, smooth and curing complete | | |
| 18.61.1 | in CM 1:3 | Sqm | 172 |
| 18.61.2 | in CM 1:4 | Sqm | 160 |
| 18.61.3 | in CM 1:5 | Sqm | 150 |
| 18.61.4 | in CM 1:6 | Sqm | 145 |
| 18.61.5 | Neat cement punning | Sqm | 27 |
| 18.62 | 18mm thick cement plaster in 2 coats under layer 12mm CP 1:5 (1 cement:5 coarse sand) and top layer 6mm thick cement plaster 1:3 (1 cement:3 fine sand) finished even, smooth and curingcomplete. | Sqm | 199 |

| S.No. | Items | Unit | Rates in Rs. |
|---------|---|------|--------------|
| 18.63 | 20 mm thick cement plaster in single coat i/c finishing even, smooth and curing complete | | |
| 18.63.1 | in CM 1:3 | Sqm | 215 |
| 18.63.2 | in CM 1:4 | Sqm | 197 |
| 18.63.3 | in CM 1:5 | Sqm | 186 |
| 18.63.4 | in CM 1:6 | Sqm | 180 |
| | FORM WORK | | |
| 18.64 | Providing & fixing form work i/c centering and shuttering including strutting, propping etc. and removal of form work for: | | |
| 18.64.1 | Foundation , footing, bases of columns ,etc for mass concrete | sqm | 185 |
| 18.64.2 | Wall (any thickness) including attached pilasters, buttresses, plinth and string courses etc. | sqm | 322 |
| 18.64.3 | Suspended floors, roofs, landings, balconies and access platform. | sqm | 360 |
| 18.64.4 | Lintels, beams , plinth beams, girders, bressumers and cantilevers. | sqm | 303 |
| 18.64.5 | Columns, pillars, piers, Abutments, posts and Struts | sqm | 413 |
| 18.64.6 | Stairs, (excluding landings) except spiral- staircases | sqm | 436 |
| 18.65 | Close timbering in trenches including strutting, shoring and packing cavities (wherever required) complete (Measurement to be taken of the face area timbered) | | |
| 18.65.1 | Depth not exceeding 1.5 mtr. | Sqm | 171 |
| 18.65.2 | Depth exceeding 1.5 mtr. but not exceeding 3.0 mtr. | Sqm | 176 |
| 18.65.3 | Depth exceeding 3.0 mtr. but not exceeding 4.5 mtr. | Sqm | 181 |
| 18.65.4 | Depth exceeding 4.5 mtr. but not exceeding 6.0 mtr. | Sqm | 186 |
| 18.65.5 | Depth exceeding 6.0 mtr. but not exceeding 7.5 mtr. | Sqm | 191 |
| 18.65.6 | Depth exceeding 7.5 mtr. but not exceeding 9.0 mtr. | Sqm | 196 |
| 18.66 | Close Timbering in case of shafts, wells, cesspits manholes and the like including strutting, shoring and packing cavities (wherever required) etc. complete (Measurements to be taken of the face area timbered) | | |
| 18.66.1 | Depth not exceeding 1.5 mtr. | Sqm | 174 |
| 18.66.2 | Depth exceeding 1.5 mtr. but not exceeding 3.0 mtr. | Sqm | 184 |
| 18.66.3 | Depth exceeding 3.0 mtr. but not exceeding 4.5 mtr. | Sqm | 195 |
| 18.66.4 | Depth exceeding 4.5 mtr. but not exceeding 6.0 mtr. | Sqm | 205 |

| S.No. | Items | Unit | Rates in Rs. |
|---------|--|------|--------------|
| 18.66.5 | Depth exceeding 6.0 mtr. but not exceeding 7.5 mtr. | Sqm | 216 |
| 18.66.6 | Depth exceeding 7.5 mtr. but not exceeding 9.0 mtr. | Sqm | 226 |
| | STONE WORK | | |
| 18.67 | Coursed rubble masonry (first sort) with hard stone in foundation and plinth cement mortar 1:6 | cum | 4414 |
| 18.68 | Coursed rubble masonry (Second sort) with hard stone in foundation and plinth Cement mortar 1:6 | cum | 4115 |
| 18.69 | Coursed rubble masonry with hard stone (first or Second sort) in Superstructure above plinth level and up to floor two level. | | |
| 18.69.1 | Masonry work (first sort) in Cement mortar 1:6 | cum | 5054 |
| 18.69.2 | Masonry work (Second sort) in Cement mortar 1:6 | cum | 4756 |
| 18.70 | Extra Coursed rubble masonry with hard stone (first or Second sort) in Superstructure above floor II level for every floors or part thereof. | cum | 112 |
| 18.71 | Extra Coursed rubble masonry with hard stone (first or Second sort) in | | |
| 18.71.1 | Square or rectangular pillars | cum | 372 |
| 18.71.2 | Circular pillars | cum | 1249 |
| 18.72 | Pointing on stone work with cement mortar 1:3 (1 cement : 3 fine sand) | | |
| 18.72.1 | Flush / ruled pointing | sqm | 129 |
| 18.72.2 | Raised and cut pointing | sqm | 236 |
| | FINISHING WORK | | |
| 18.73 | White washing with lime to give an even shade : New work (three or more coats) | sqm | 15 |
| 18.74 | White washing with lime to give an even shade : | | |
| 18.74.1 | Old work (two or more coats) | sqm | 9 |
| 18.74.2 | Old work (One or more coats) | sqm | 5 |
| 18.75 | Finishing walls with water proofing cement paint of required shade : New work (two or more coats applied @ 3.84 kg/10 sqm) | sqm | 54 |

| S.No. | Items | Unit | Rates in Rs. |
|--------------|---|-------------|---------------------|
| 18.76 | Finishing walls with Acrylic Smooth exterior paint of required shade : New work (two or more coats applied @ 1.67 ltr/10 sqm over and including priming coat of exterior primer applied @ 2.20 kg/ 10sqm) | sqm | 93 |
| 18.77 | Painting with synthetic enamel paint of approved brand and manufacture to give an even shade : (two or more coats) on New work | sqm | 69 |
| 18.78 | Painting with synthetic enamel paint of approved brand and manufacture to give an even shade : (One or more coats) on Old work | sqm | 46 |
| | CONSTRUCTION OF BRICK MASONARY VALVE CHAMBER | | |
| 18.79 | Construction of Brick masonry valve chamber with 20 cm thick wall in 1:6 C.M. with 12mm thick 1:4 Cement Plaster and base course 10 cm. thick in M-15. Inside Dimensions 110x80x100cm M-20 RCC chamber cover size 130x100cmx120cm including cost of materials, labour etc.complete. | No. | 6323 |

CHAPTER- XIX
GENERAL MISCELLANEOUS

CHAPTER – XIX

GENERAL MISCELLANEOUS

NOTES:

1. The rates include all tools and plants, chain, pulley blocks, other appliances etc. required for execution of the works.
2. The works to be executed in accordance with the I.S.Specifications, General specifications in vogue in P.H.E. Department and the special notes if any covered under the N.I.T. of the work.
3. Rates for items of cutting and making good roads etc. include lead for the materials and reconstruction by appropriate compaction equipment and methods as per relevant IS Codes.
4. Where cracked pipe or cut piece is required to be used on line to take a tyton ring joint, it is necessary to cut the cracked portion and chamfer for the pipe. In a cut piece, only chamfering would be required. These rates have been introduced separately for cutting and chamfering. The rates include requirement of tools and plants, lead and lift etc.
5. During the course of execution, it sometimes becomes necessary to provide a non-standard special to fit into the pipeline. This can be made out of steel plates.
6. All materials shall conform to relevant ISS.
7. Pavement and road surface may be removed as a part of the trench excavation and the amount removed shall depend upon the width of trench specified for the installation of the pipe and the width and length of the pavement area required to be removed for laying pipes. The width of pavement removal along the normal trench for the installation of the pipe shall not exceed the width of the trench specified by more than 15 CM on each side of the trench. Wherever in the opinion of the Engineer in charge existing conditions make it necessary or advisable to remove additional pavement, it shall be removed as directed by the Engineer in charge.
8. Where any pavement, shrubbery, fence, poles or other property and surface structures have been damaged, removed or disturbed during the course of the work, such property and surface structures shall be replaced or repaired after completion of work.
9. All pavements, paved foot paths, curbing, gutters, shrubbery, fences, poles, rod or other property and surface structures removed or disturbed as a part of the work shall be restored to a condition equal to that before the work began, furnishing all labour and material incidental thereto. In restoring the pavement sound materials may be reused. No Permanent pavements shall be restored unless and

until, in the opinion of the Engineer in charge the condition of the backfill is such as to properly support the pavement.

10. All construction material, and all tools and temporary structures shall be removed from the site as directed by the Engineer in charge. All dirt, rubbish and excess earth from the excavation shall be taken off to a specified dumping site as directed by Engineer in Charge and the construction site shall be kept clean to the satisfaction of the Engineer-in-charge.
- 11 **This USOR contains the rates of all the items without GST. No claims against GST shall be entertained at any level. GST shall be paid by the Agency/ Contractor directly to the concerning department. However, All the estimates prepared on this USOR will include GST, as an extra amount as per prevailing rates on the sum of the estimate to arrive at the gross amount.**

GENERAL MISCELLANEOUS

| S. No. | Items | Unit | Rates in Rs. |
|-------------|--|---------|--------------|
| 19.1 | Labour for cutting following cast iron pipes of any type and class. | | |
| | 80 mm dia. | Per Cut | 49 |
| | 100 mm dia. | Per Cut | 66 |
| | 150 mm dia. | Per Cut | 123 |
| | 200 mm dia. | Per Cut | 165 |
| | 250 mm dia. | Per Cut | 204 |
| | 300 mm dia. | Per Cut | 245 |
| | 350 mm dia. | Per Cut | 285 |
| | 400 mm dia. | Per Cut | 325 |
| | 450 mm dia. | Per Cut | 365 |
| | 500 mm dia. | Per Cut | 407 |
| | 600 mm dia. | Per Cut | 483 |
| | 700 mm dia. | Per Cut | 523 |
| | 750 mm dia. | Per Cut | 562 |
| | 800 mm dia. | Per Cut | 603 |
| 900 mm dia. | Per Cut | 644 | |
| 19.2 | Labour for cutting following Asbestos Cement Pressure Pipes of any type and class. | | |
| | 80 mm dia. | Per Cut | 24 |
| | 100 mm dia. | Per Cut | 34 |
| | 150 mm dia. | Per Cut | 62 |
| | 200 mm dia. | Per Cut | 82 |
| | 250 mm dia. | Per Cut | 102 |
| | 300 mm dia. | Per Cut | 113 |
| | 350 mm dia. | Per Cut | 130 |

| S. No. | Items | Unit | Rates in Rs. |
|---------------|---|-------------|---------------------|
| 19.3 | Labour for cutting following P. V. C. Pipes of any type and class. | | |
| | 80 mm dia. | Per Cut | 12 |
| | 100 mm dia. | Per Cut | 16 |
| | 150 mm dia. | Per Cut | 31 |
| | 200 mm dia. | Per Cut | 42 |
| 19.4 | Labour only for cutting following Ductile Iron pipes of any type and class. | | |
| | 80 mm dia. | Per Cut | 43 |
| | 100 mm dia. | Per Cut | 58 |
| | 150 mm dia. | Per Cut | 108 |
| | 200 mm dia. | Per Cut | 144 |
| | 250 mm dia. | Per Cut | 180 |
| | 300 mm dia. | Per Cut | 216 |
| | 350 mm dia. | Per Cut | 250 |
| | 400 mm dia. | Per Cut | 286 |
| | 450 mm dia. | Per Cut | 321 |
| | 500 mm dia. | Per Cut | 358 |
| | 600 mm dia. | Per Cut | 425 |
| | 700 mm dia. | Per Cut | 460 |
| | 750 mm dia. | Per Cut | 495 |
| | 800 mm dia. | Per Cut | 531 |
| 900 mm dia. | Per Cut | 566 | |
| 19.5 | Labour for cutting following Galvanised Iron (MS) Pipes of any type and class. | | 0 |
| | 15 mm dia. | Per Cut | 4 |
| | 20 mm dia. | Per Cut | 7 |
| | 25 mm dia. | Per Cut | 10 |
| | 32 mm dia. | Per Cut | 15 |
| | 40 mm dia. | Per Cut | 20 |
| | 50 mm dia. | Per Cut | 24 |
| | 65 mm dia. | Per Cut | 29 |
| | 80 mm dia. | Per Cut | 38 |
| | 100 mm dia | Per Cut | 40 |
| | 125 mm dia | Per Cut | 46 |
| | 150 mm dia | Per Cut | 51 |
| 19.6 | Chamfering of CI/DI pipes of all types and classes to make suitable for tyton joints. | | |
| | Up to 150 mm dia. | Each End | 865 |
| | 200 mm dia. | Each End | 1077 |

| S. No. | Items | Unit | Rates in Rs. | | |
|---------------|---|-------------|---------------------|--------------------|--------------------|
| | 250 mm dia. | Each End | 1187 | | |
| | 300 mm dia. | Each End | 1348 | | |
| | 400 mm dia. | Each End | 1618 | | |
| | 450 mm dia. | Each End | 1759 | | |
| | 500 mm dia. | Each End | 1888 | | |
| | 600 mm dia. | Each End | 2158 | | |
| | 700 mm dia. | Each End | 2427 | | |
| | 750 mm dia. | Each End | 2697 | | |
| | 800 mm dia. | Each End | 2967 | | |
| | 900 mm dia. | Each End | 3236 | | |
| | 1000 mm dia. | Each End | 3201 | | |
| 19.7 | Dismantling following old cast iron socket and spigot pipes class 'L.A.' 'A' & 'B' including breaking lead caulked joints, melting of lead and making it in to blocks including stacking of pipes at site lead upto 60mtrs. | | Class LA | Class A | Class B |
| | 80 mm dia. | R.Mtr. | 9 | 10 | 11 |
| | 100 mm dia. | R.Mtr. | 11 | 12 | 13 |
| | 125 mm dia. | R.Mtr. | 15 | 16 | 17 |
| | 150 mm dia. | R.Mtr. | 18 | 20 | 22 |
| | 200 mm dia. | R.Mtr. | 27 | 29 | 32 |
| | 250 mm dia. | R.Mtr. | 37 | 40 | 43 |
| | 300 mm dia. | R.Mtr. | 48 | 52 | 55 |
| | 350 mm dia. | R.Mtr. | 60 | 65 | 69 |
| | 400 mm dia. | R.Mtr. | 73 | 80 | 85 |
| | 450 mm dia. | R.Mtr. | 88 | 98 | 103 |
| | 500 mm dia. | R.Mtr. | 104 | 113 | 120 |
| | 600 mm dia. | R.Mtr. | 138 | 152 | 160 |
| | 700 mm dia. | R.Mtr. | 178 | 194 | 206 |
| | 750 mm dia. | R.Mtr. | 198 | 217 | 232 |
| | 800 mm dia | R.Mtr. | 280 | 307 | 335 |
| | 900 mm dia | R.Mtr. | 341 | 375 | 410 |

| S. No. | Items | Unit | Rates in Rs. | | |
|----------------|---|-----------------|--------------|---------------------|-----|
| | | | | | |
| | 1000 mm dia. | R.Mtr. | 410 | 451 | 491 |
| 19.8 | Unloading from railway wagon, pipes and machinery | | | | |
| (a) | Pipes upto 500 mm dia and machinery below 1.00 tonne | Tonne | | 458 | |
| (b) | Pipes 500 mm dia and above heavy Machinery weighing more than one tonne require use of crane etc. | Tonne | | 2074 | |
| 19.9 | Stacking of pipe and machinery at station Yard. | Tonne | | 590 | |
| 19.10 | Carriage of Material by Mechanical transport including loading unloading & stacking etc. | | | | |
| 19.10.1 | Lime, Alum., Bleaching Powder | Distance | Per | Rates in Rs. | |
| | 1. Distance | 1 Km. | Cum | 92 | |
| | 2. Distance | 2 km | Cum | 105 | |
| | 3. Distance | 3 km | Cum | 118 | |
| | 4. Distance | 4 km | Cum | 130 | |
| | 5. Distance | 5 km | Cum | 142 | |
| | 6. Beyond 5km upto 10km. add per km | | Cum | 10 | |
| | 7. Beyond 10km upto 20km add per km | | Cum | 8 | |
| | 8. Beyond 20km. add per km. | | Cum | 7 | |
| 19.10.2 | Earth & Moorum | | Cum | | |
| | 1. Distance | 1 km | Cum | 115 | |
| | 2. Distance | 2 km | Cum | 131 | |
| | 3. Distance | 3 km | Cum | 147 | |
| | 4. Distance | 4 km | Cum | 163 | |
| | 5. Distance | 5 km | Cum | 178 | |
| | 6. Beyond 5km upto 10km. add per km | | Cum | 12 | |
| | 7. Beyond 10km upto 20km add per km | | Cum | 10 | |
| | 8. Beyond 20km. add per km. | | Cum | 8 | |
| 19.10.3 (a) | G.I.,C.I.,ACP Pipes below 100mm dia and other heavy material and machinery | | Cum | | |
| | 1. Distance | 1 km | Per Tonne | 81 | |
| | 2. Distance | 2 km | Per Tonne | 94 | |
| | 3. Distance | 3 km | Per Tonne | 105 | |
| | 4. Distance | 4 km | Per Tonne | 116 | |
| | 5. Distance | 5 km | Per Tonne | 126 | |
| | 6. Beyond 5km upto 10km. add per km | | Per Tonne | 9 | |
| | 7. Beyond 10km upto 20km add per km | | Per Tonne | 7 | |
| | 8. Beyond 20km. add per additional | | Per Tonne | 6 | |

| S. No. | Items | Unit | Rates in Rs. | |
|----------------|---|-------|--------------|------|
| 19.10.3 (b) | PVC pipes- 90,110,140,160,180,200 mm dia pipes | | | |
| | 1. Distance | 1 km | Per Tonne | 207 |
| | 2. Distance | 2 km | Per Tonne | 235 |
| | 3. Distance | 3 km | Per Tonne | 264 |
| | 4. Distance | 4 km | Per Tonne | 290 |
| | 5. Distance | 5 km | Per Tonne | 317 |
| | 7. Beyond 5km upto 10km add per km | | Per Tonne | 23 |
| | 7. Beyond 10km upto 20km add per km | | Per Tonne | 19 |
| | 8. Beyod 20 km. add per additional | | Per Tonne | 16 |
| 19.10.4 | Steel (All types) | | | |
| | 1. Distance | 1 km | Per Tonne | 81 |
| | 2. Distance | 2 km | Per Tonne | 94 |
| | 3. Distance | 3 km | Per Tonne | 105 |
| | 4. Distance | 4 km | Per Tonne | 116 |
| | 5. Distance | 5 km | Per Tonne | 126 |
| | 6. Beyond 5km upto 10km. add per km | | Per Tonne | 9 |
| | 7. Beyond 10km. upto 20km. add per km. | | Per Tonne | 7 |
| | 8. Beyond 20km. add per additional km. | | Per Tonne | 6 |
| 19.10.5 | R.C.C., Pipes, Steel Pipes, ACP pipes, CI & DI Pipes | | | |
| 19.10.5.1 | 100,150,200,250,&300 mm dia | | | |
| | 1. Distance | 1 Km. | Per Tonne | 187 |
| | 2. Distance | 2 km | Per Tonne | 213 |
| | 3. Distance | 3 km | Per Tonne | 237 |
| | 4. Distance | 4 km | Per Tonne | 260 |
| | 5. Distance | 5 km | Per Tonne | 284 |
| | 6. Beyond 5km upto 10km. Add per km | | Per Tonne | 20 |
| | 7. Beyond 10km. upto 20km. add per km. | | Per Tonne | 17 |
| | 8. Beyond 20km. add per additional km. | | Per Tonne | 13 |
| 19.10.5.2 | 350,100,450,& 500 mm dia | | | |
| | 1. Distance | 1 Km. | Per Tonne | 1249 |
| | 2. Distance | 2 km | Per Tonne | 1414 |
| | 3. Distance | 3 km | Per Tonne | 1579 |
| | 4. Distance | 4 km | Per Tonne | 1737 |
| | 5. Distance | 5 km | Per Tonne | 1890 |
| | 6. Beyond 5km upto 10km. add per km | | Per Tonne | 137 |
| | 7. Beyond 10km. upto 20km. add per km. | | Per Tonne | 112 |

| S. No. | Items | Unit | Rates in Rs. | |
|-----------|---|-------|--------------|-------|
| | 8.Beyond 20km. add per additional km | | Per Tonne | 92 |
| 19.10.5.3 | 600,700,750,800&900mm dia | | | |
| | 1. Distance | 1 Km. | Per Tonne | 3122 |
| | 2. Distance | 2 km | Per Tonne | 3536 |
| | 3. Distance | 3 km | Per Tonne | 3947 |
| | 4. Distance | 4 km | Per Tonne | 4341 |
| | 5. Distance | 5 km | Per Tonne | 4725 |
| | 6. Beyond 5km upto 10km. add per km | | Per Tonne | 342 |
| | 7. Beyond 10km. upto 20km. add per km. | | Per Tonne | 281 |
| | 8.Beyond 20km. add per additional km. | | Per Tonne | 228 |
| 19.10.5.4 | 1000,1100, and 1200 mm dia | | | |
| | 1. Distance | 1 Km. | Per Tonne | 6242 |
| | 2. Distance | 2 km | Per Tonne | 6800 |
| | 3. Distance | 3 km | Per Tonne | 7893 |
| | 4. Distance | 4 km | Per Tonne | 8682 |
| | 5. Distance | 5 km | Per Tonne | 9449 |
| | 6. Beyond 5km upto 10km. add per km | | Per Tonne | 684 |
| | 7. Beyond 10km. upto 20km. add per km. | | Per Tonne | 560 |
| | 8. Beyond 20km. add per additional km. | | Per Tonne | 456 |
| 19.11 | Providing and installation of automatic water level indicator for supervisory control cum auto on/off of motor pump assembly inclusive of control panel ,500 mtr long 2 core ,4 pair cable for small rural water supply scheme, having source within 500mtr as per approved specification and as directed by Engineer in charge.(In case of lesser length of cable,equivalent amount @ Rs 12 /-per meterofshort length will bededucted from above rate) | 1 Job | | 18302 |

| S. No. | Items | Unit | Rates in Rs. | |
|--------|--|-------|--------------|-------|
| 19.12 | Providing and installation of automatic water level indicator for supervisory control cum auto on/off panel of motor pump assembly, using GSM module based water level controller and accessories for small water supply scheme, having source more than 500mtr but within 10 Kms as per approved specification and as directed by Engineer in charge. | 1 Job | | 25420 |
| 19.13 | Providing and supply of Electro Fusion Tapping Ferrule (Branch Tapping saddle) Female BSP Threaded with SS 304 insert fittings in accordance with BS EN 12201: Part-3 suitable for drinking water with in black/ blue color manufactured from compounded PE 80/ PE-100 virgin polymer and compatible with PE80/PE 100 pipes, in pressure rating SDR 11 with min PN 12.5 rated for water application with electro fusion tapping ferrule saddle, 90x15mm and providing and supplying blue 20mm dia PN-16 MDPE pipes 5-10 mtr confirming to IS 4427:1996 Manufactured from virgin resin PE 80 food grade compounded Raw Material having Blue color only with quality assurance certificate from quality agencies like WRC/ CIPET (India) / DVGM/ KIWA/ SPGN etc. for usage in drinking water system the cost shall include testing of all materials all taxes central, state municipal inspection charges transportation up to site, transit insurance, loading, unloading, stacking etc. complete i/c cost of 15mm dia UPVC pipe socket, Elbow, Union 20x15 mm dia PVC reducer and providing and stainless steel water tap with grouting of vertical pipe as per requirement as per approved specification and as directed by Engineer in charge. | No. | | 2013 |

| S. No. | Items | Unit | Rates in Rs. | |
|--------|--|-------|--------------|------|
| 19.14 | House hold connection with 15mm S.S. tap including earth work in excavaton for pipe trench in all kinds of soil & W.B.M. in areas with demolishing cement concrete road and reconstruction of same good with providing and fixing 15mm G.M./ brass ferrule 90x15mm MS/ PVC Clamp in main line 15mm dia PVC pipe heavy class from main pipe line to house of consumer up to 5 to 10 meter long as per site condition PVC specials such as 15mm PVC sockets elbows, union with all other work pertaining to it job completed, as per approved specification and as directedbyEngineer incharge | 1 Job | | 1647 |
| 19.15 | House hold connection with 15mm S.S. tap including earth work in excavaton for pipe trench in all kinds of soil & W.B.M. in areas with demolishing cement concrete road and reconstruction of same good with providing and fixing 15mm G.M./ brass ferrule 90x15mm MS/ PVC Clamp in main line, 15mm dia G.I. pipe from main pipe line to house of consumer up to 5 to 10 meter long as per site condition i/c specials such as G.I. Bends, elbows, tees,union etc. with all other work pertaining to job completed, as per approved specificationand as directed by Engineer incharge | Job | | 1830 |
| | RECTANGULAR CONCRETE BLOCK PAVEMENT | | | |
| 19.16 | Manufacturing, laying of cement concrete blocks of cement Concrete (C.C.) M30 grade and spreading 25mm thick sand under neath and filling joints with sand on existing baseincludingtesting. | | | |
| (i) | Concrete M30 grade for block, (0.600x0.450x0.200) with | Sqm | | 1292 |
| | (Concrete M30 for edge block, (0.300x0.300x0.300)) | | | |
| | Concrete M30 grade for block, (0.450x0.300x0.150) with | Sqm | | 1094 |

| S. No. | Items | Unit | Rates in Rs. | |
|--------------|---|------|--------------|-------|
| (ii) | (Concrete M30 for edge block, (0.300x0.300x0.300)) | | | |
| | INTERLOCKING CONCRETE BLOCK PAVEMENT | | | |
| 19.17 (i) | Providing and Laying of Interlocking Concrete Block Pavements having thickness 80 mm over bedding sand conforming to table 1500.6 shall be uniformly laid to a compacted thickness of 30mm complete including testing. | Sqm | | 506 |
| (ii) | Providing and Laying of Interlocking Concrete Block Pavements having thickness 60 mm over bedding sand conforming to table 1500.6 shall be uniformly laid to a compacted thickness of 25mm complete. | Sqm | | 438 |
| 19.18 | Supply & erection of readymade mini pump house (control panel box) GI sheet of 18 gauge of size 90cmx90cm x60cm with 40x40x5mm angle Iron frame to fix it 200mm below ground level with hold fasts grouted in foundation and 300mm above ground level for clearance suitable for fixing of control panel, fuse unit, mainswitch etc. as per approved specification. | Each | | 13727 |
| 19.19 | Provision for Jointing of TW to Rising Main with cost of Material/ specials such as GI Union / CI Flange,GI Reducer UPVC MTA FTA etc. as per | Job | | 2745 |
| | requirement of site i/c cost of labour etc. complete as per approved specification and as directed by Engineer in charge. | | | |
| 19.20 | Provision for jointing of Rising main to supply well/OHT and OHT to Distribution pipe line with cost of material/specials such as Bends, MTA as per requirement of site i/c cost of labour with excavation, labour as per requirement complete as per approved specification and as directed by Engineer in charge. | Job | | 4576 |

| S. No. | Items | Unit | Rates in Rs. | |
|---------------|--|-------------|---------------------|------|
| 19.21 | Providing and Installation of automatic water level controller (Auto switch off) with accessories i/c labour and material etc. complete, as per approved specification and directed by Engineer in charge. | Job | | 7321 |
| 19.22 | Provision for inter connection of old to new pipe line with excavation of trench as per requirement/ repairing of leakage of pipe line of any diameter & type of pipe line in muddy area i/c searching of leakage point, dewatering the trench, repairing the leakage laying & jointing of pipe and specials, back filling the trench i/c testing of joints cost of labour & specials such as D- joints couplers, solvent cement etc. complete Job work as per approved specification and as directed by Engineer in charge. | | | |
| | 50mm dia | Job | | 1373 |
| | 90mm dia | Job | | 1830 |
| | 110mm dia | Job | | 2288 |
| 19.23 | Provision for inter connection of old to new pipe line with excavation of trench as per requirement of any diameter & type of pipe line in muddy area i/c dewatering the trench laying & jointing of pipe and specials, back filling the trench i/c testing of joints cost of labour & specials such as D-Joints couplers, solvent cement etc, complete job work as per approved specification and as directed by Engineer in charge. | | | |
| | 50/90mm dia | Job | | 1601 |
| | 90/110 mm dia | Job | | 2059 |
| | 110/110mm dia | Job | | 2288 |
| | 90/90 mm dia | Job | | 1830 |

| S. No. | Items | Unit | Rates in Rs. | |
|---------------|---|-------------|---------------------|-------|
| 19.24 | Supply of Woltman Turbine Bulk meter class b, multijet, magnetically coupled as per specifications conforming to IS 770/1994, ISO 4064/1 and EEC approved, including transportation to site, storage, safety, installation, testing commissioning, making connection with existing pipeline having total measuring capacity of 10,000 Kilolitre with least count of one Kilolitre including excavation at site, dewatering and reinstating the same after completion and as per specifications including all taxes. | Job | | 13727 |
| 19.25 | Provision for Rewinding of submersible Motor of any diameter i/c cost of material, labour, transportation etc. complete in case of breakdown maintenance as per approved specification and as directed by Engineer in charge. | Job | | 4576 |
| 19.26 | Provision for Repairing of submersible pump of any diameter i/c cost of material, labour, transportation etc. in case of breakdown maintenance as per approved specification and as directed by Engineer in charge | Job | | 2288 |
| 19.27 | Provision for Repairing of Starter/control panel i/c cost of material, labour, transportation etc. complete as per approved specification and as directed by Engineer in charge | Job | | 1098 |
| 19.28 | Provision for Repairing of old existing CI Sluice Valve i/c repairing of spindle, check nut, changing of gland, lathe work as per requirement, changing of nut bolt, rubber sheet etc. complete as per approved specification and as directed by Engineer in charge. | Job | | 1271 |
| | BOUNDARY PILLAR | | | |
| 19.29 | Reinforced cement concrete M15 grade boundary pillars/local stone of standard design, fixed in position including finishing and lettering but excluding painting . | Each | | 478 |

| S. No. | Items | Unit | Rates in Rs. | |
|---------------|--|-------------|---------------------|-------|
| | G.I.BARBED WIRE FENCING 1.2 M. HIGH | | | |
| 19.30 | Providing and fixing 1.2 m high GI barbed wire fencing with 1.8 m RCC posts 150 mm x 150 mm placed every 3 m centre-to-centre founded in M15 grade cement concrete, 0.6 m below ground level, every 15th post, last but one end post and corner post shall be strutted on both sides and end post on one side only and provided with 9 horizontal lines and 2 diagonals interwoven with horizontal wires, fixed with GI staples, turn buckles etc. omplete. | R.M. | | 363 |
| | G.I. BARBED WIRE FENCING 1.8 M. HIGH | | | |
| 19.31 | Providing and fixing 1.8 m high GI barbed wire fencing with 2.4 m RCC M15 grade 150 mm x 150 mm concrete post placed every 3 m centre-to-centre founded in M15 grade cementconcrete, 0.6 m below ground level, every 15th post, last but one end post and corner post shall be strutted on both sides and end post on one side only and provided with 12 horizontal lines and 2 diagonals interwoven with horizontal wires, fixed with GI staples, turn buckles etc. complete. | R.M. | | 511 |
| | SIGN BOARD | | | |
| 19.32 | Providing and fixing of typicalinformatory sign board. Three MS Plates of 1.6 mm thick, top and middle plate duly welded with MS flat iron 25mm x 5m size on back on edges. The lower plate will be welded with MS angle iron frame of 25mm x 25mm x 5mm. The angle iron frame of the lower most plate and flat iron frame of middle plate will be welded to 2 nos. 75mm x 75 mm of 12 SWG sheet tubesposts duly embedded in cement concreteM- | Job | | 12676 |

| S. No. | Items | Unit | Rates in Rs. | |
|--------|---|------|--------------|-------|
| | 15 grade blocks of 450mm x 450mm x 600mm, 600mm below ground level. The top most diamond plate will be welded to middle plate by 47mm x 47mm of 12 SWG steel platetube. AllM.S. will be stove enameled on both sides. Lettering and printing arrows, border etc. will be painted with readymixed synthetic enamel paint of superior quality in required shade and colour. All sections of framed posts and steel tube will be painted with primer and two coats of epoxy paintcomplete. | | | |
| 19.33 | Construction of cement concrete information board in CC 1:2.5:5 (M15) with skin reinforcement of 8 mm dia HYSD bars @ 300 mm C/C both ways size including excavation, base concrete (M-15), priming, painting two coats synthetic enamel paint on new concrete surface including painting-figring Logo and Slogen including writing of all information about the project etc. complete. As directed by the Engineer in charge. | Job | | 9306 |
| 19.34 | Providing and fixing of typical information board made of 75mm square or 75mm dia. circular steel tube of 12 SWG 3.2 m high and cross member 2 Nos. 1m long, fixed with Angle iron 50 x 50 x 5 mm MS angle on the back side 2Nos vertical and 4 Nos horizontal. It is mounted by 2 plates of 1.6mm thick and size 900 x 750 mm, the pipe shall be erracted on 600 x 600 x 750 mm foundation blocks at appropriate depth made of cement concrete 1:2:4, painted by standard color with lettering, border, heading and logo etc. using sinthetic enamel paint of superior quality including welding, excavation, concreting, painting of base, border and lettering, painting andother required details etc completeasdirected by Engineer-in-charge. | Job | | 17322 |

PE-AL-PE PIPES & FITTINGS

FOR HOT & COLD WATER SUPPLIES

12 PE-AL-PE Pipes shall Conform to IS: 15450 duly inspected and tested and having BIS certification mark.

13 SCOPE

This standard covers coextruded polyethylene composite pressure pipes ranging from 12 mm to 50 mm in diameter. These pipes are used for conveyance of hot and cold water supply for domestic and industrial purposes including internal and external plumbing, air conditioning and heating installations within buildings. This standard includes a system of nomenclature for PE-AL-PE pipes, the requirements and test methods for material, the dimensions and strength of finished pipe, adhesion test and the burst and sustained pressure performance test along with requirements and methods for marking.

13. Polyethylene compounds shall Conform to IS 7328 as follows:

- PEEWA 45 T006 for black pipes
- PEELA 45 T006 for coloured pipes

14. NOMINAL DIAMETERS

The nominal outside diameter of pipes are 12, 14, 16, 20, 25, 32, 40 and 50 mm. Respective nominal inside diameters are 9, 10, 12, 16, 20, 25, 32 and 40 mm.

15. The PE-AL-PE pipes are bonded, multilayer pipes consisting of metal aluminum and polyethylene i.e. metallic pipe bonded with adhesive both internally and externally by polyethylene coating. The layers of PE-AL-PE pipes are :-

- The interior layer of polyethylene
- The adhesive layer
- Aluminium tube
- The adhesive layer
- The external layer of polyethylene

Table -1 Aluminium Thickness and Tolerances for PE-AL-PE

| S.No | Nominal Pipe Size mm | Nominal Aluminium Thickness mm |
|-------|-------------------------|-----------------------------------|
| 1 | 2 | 3 |
| i) | 912 | 0.2 |
| ii) | 1014 | 0.2 |
| iii) | 1216 | 0.2 |
| iv) | 1620 | 0.25 |
| v) | 2025 | 0.25 |
| vi) | 2532 | 0.3 |
| vii) | 3240 | 0.3 |
| viii) | 4050 | 0.3 |

16. MARKING

- The marking shall be repeated at intervals of 1 m and shall consist of the following information:
 - a) Manufacturer's name and trade-mark,
- Two labels of suitable dimensions should be carefully attached to each coil indicating:
 - b) suppliers name;
 - c) BIS Certification Marking
- Each pipe may also be marked with the Standard Mark.

17. The jointing of the pipe to ensure a leak proof joint :

- Cut the pipe square by cutter to the required and proper length.
- Select the fitting to be used and dismantle its nuts and split rings.
- Place the nut and split ring over the pipe
- Prepare the end of pipe to be jointed for roundness and chamfer by using beveling tool. Push the pipe over the insert and inside the support groove fully.
- Push the split ring and nut towards connector till split ring touches the support groove.
- Tighten the nut over connector with spanner.

18. The specially manufactured compression joints fittings should be used for PE-AL-PE pipes which are available in 3 types i.e. brass, composite and composite external sealing. Either of these fittings should be used. The external sealing fittings should be used only for cold water applications.

19. Measurement:

- The net length of pipes as laid or fixed should be measured in running meters correct to a cm. Specials should be excluded and enumerated and paid for separately.
- The outside diameter of pipe shall be taken as the average of two measurements taken at right angles. The wall thickness shall be measured by a dial vernier or ball ended micrometer. The resulting dimension shall be expressed to the nearest 0.1 mm.

- Ovality shall be measured as the difference between maximum outside diameter and minimum outside diameter measured at the same cross section of the pipe. For pipes to be coiled, the ovality shall be measured prior to coiling. For coiled pipes, however, re-rounding the pipes shall be carried out prior to the measurement of ovality.

20. Rates

- The rates include charges pipes/specials/civil works (like digging of trenches, refilling of trenches), for all tools & plants, chain pulley blocks, other appliances etc. required for lifting and laying the pipes and specials in positions as per approved drawing.
- The rates include provision and use of all coverings etc. to protect the works from inclement weather etc. and from damages from fall of materials, and other causes.
- **This USOR contains the rates of all the items without GST. No claims against GST shall be entertained at any level. GST shall be paid by the Agency/ Contractor directly to the concerning department. Howerer, All the estimates prepared on this USOR will include GST, as an extra amount as per prevailing rates on the sum of the estimate to arrive at the gross amount**

PE-AL-PE PIPES & FITTINGS FOR HOT & COLD WATER SUPPLIES

| Sr. No. | Particulars of Item | Unit | Rate in Rs |
|---------|---|------|------------|
| 19.35 | Providing and constructing one stand post as per type design with excavation 15 cm thick PCC 1:3:6 bedding 20 mm thick PCC 1:2:4 convert for platform of 1.5mx1.5m with side curb and bucket rest of 80 mm dia. 160mm dia PVC pipe central post duly filled therein with C.C. 1:2:4, 2.2m long, 15 mm dia medium G.I. pipe. From point of tapping to stand post additional 1620 (20 mm dia) composite pipe 6.0 m long. Providing and fixing of 15 mm dia, one steel water tap, one flow control valve SS, 5 LPM complete together with all labour and material charges as per drawing and as directed by Engineer-in-charge when good foundation in available. Rate includes draining arrangement by excavating open gutters complete | Each | 6969 |
| 19.36 | Providing and fixing Polyethylene-Aluminum-Polyethylene (PE-AL-PE) Composite Pressure pipes Conforming | | |

| Sr. No. | Particulars of Item | Unit | Rate in Rs |
|---------|---|------|------------|
| | to IS: 15450-2004 U.V. Stablished with carbon black having thermal stability for hot & cold water supply, capable to with stand temperature up to 80 ⁰ C including all specials and fittiings of composite material (engineering plastic. gland and brass insert wherever required) e.g. elbws, tees. reducers, couplers and connectors wiith clamp at 1m spacing. This includes testing of joints complete as per the directions of engineer- in-charge (Exposed on wall). | | |
| 19.36.1 | 1216 (16 mm OD) Pipe | RM | 149 |
| 19.36.2 | 1620(20mm OD) Pipe | RM | 180 |
| 19.36.3 | 2025(25mm OD) Pipe | RM | 235 |
| 19.36.4 | 2532(32 mm OD) Pipe | RM | 345 |
| 19.36.5 | 3240(40mm OD) Pipe | RM | 451 |
| 19.36.6 | 4050(50 mm OD) Pipe | RM | 657 |
| | | | |
| 19.37 | Providing and fixing Polyethylene-Aluminum-Polyethylene (PE-AL-PE) Composite Pressure pipes Conforming to IS: 15450-2004 U.V. Stablished with carbon black having thermal stability for hot & cold water supply, capable to with stand temperature up to 80 ⁰ C including all specials and fittiings of composite material (engineering plastic. gland and brass insert wherever required) e.g. elbws, tees. reducers, couplers and connectors wiith clamp at 1m spacing. This includes testing of joints complete as per the directions of engineer- in-charge (Concealed work including cutting chases& making good the wall etc) | | |
| 19.37.1 | 1216 (16 mm OD) Pipe | RM | 210 |
| 19.37.2 | 1620(20mm OD) Pipe | RM | 260 |
| 19.37.3 | 2025(25mm OD) Pipe | RM | 335 |
| 19.37.4 | 2532(32 mm OD) Pipe | RM | 467 |
| 19.37.5 | 3240(40mm OD) Pipe | RM | 600 |
| 19.37.6 | 4050(50 mm OD) Pipe | RM | 868 |
| | | | |
| 19.38 | Providing and fixing Polyethylene- | | |

| Sr. No. | Particulars of Item | Unit | Rate in Rs |
|-----------|---|------|------------|
| | Aluminum-Polyethylene (PE-AL-PE) Composite Pressure pipes Conforming to IS: 15450-2004 U.V. Stablised with carbon black having thermal stability for hot & cold water supply, capable to with stand temperature up to 80 ⁰ C including all specials and fittiings of composite material (engineering plastic. gland and brass insert wherever required) e.g. elbws, tees. reducers, couplers and connectors wiith clamp at 1m spacing. This includes testing of joints complete as per the directions of engineer- in-charge (External work) | | |
| 19.38.1 | 1216 (16 mm OD) Pipe | RM | 137 |
| 19.38.2 | 1620(20mm OD) Pipe | RM | 175 |
| 19.38.3 | 2025(25mm OD) Pipe | RM | 218 |
| 19.38.4 | 2532(32 mm OD) Pipe | RM | 316 |
| 19.38.5 | 3240(40mm OD) Pipe | RM | 408 |
| 19.38.6 | 4050(50 mm OD) Pipe | RM | 599 |
| | | | |
| 19.39 | Providing and fixing Polyethelene-Aluminium-Polyethelene (PE-AL-PE) Composite Pressure Pipes conforming to ASTM F - 1282 U.V. stabilized with carbon black having thermal stability for hot & cold water supply, capable to withstand temperature up to 80 degree. (Pipe in trenches excluding excavation & refilling etc.) | | |
| 19.39.1 | 5063 (63 mm OD) Pipe | RM | 617 |
| 19.39.2 | 6375 (75 mm OD) Pipe | RM | 804 |
| 19.39.3 | 7590 (90 mm OD) Pipe | RM | 1067 |
| 19.39.4 | 90110 (110 mm OD) Pipe | RM | 1115 |
| | | | |
| 19.40 | Providingand fixingcomposite internal sealcompression fitting as per ASTM F: 1282-1995annexure for water supply e.g. Tees. Elbows, reducers, connectors' couplers and clamps with jointing, testing complete (including cutting andmaking good etc. if required). | | |
| 19.40.1 | Equal Tee | | |
| 19.40.1.1 | 5063 | Each | 1408 |

| Sr. No. | Particulars of Item | Unit | Rate in Rs |
|----------------|---|-------------|-------------------|
| 19.40.1.2 | 6375 | Each | 1619 |
| 19.40.1.3 | 7590 | Each | 1882 |
| 19.40.1.4 | 90110 | Each | 1975 |
| 19.40.2 | Reducing Tee | | |
| 19.40.2.1 | 6375 x with all branches | Each | 1580 |
| 19.40.2.2 | 7590 x with all branches | Each | 2228 |
| 19.40.3 | Equal Elbow | | |
| 19.40.3.1 | 5063 | Each | 625 |
| 19.40.3.2 | 6375 | Each | 1355 |
| 19.40.3.3 | 7590 | Each | 1758 |
| 19.40.3.4 | 90110 | Each | 2056 |
| 19.40.4 | Male Thread Connector | | |
| 19.40.4.1 | 5063 x 63 mm thread | Each | 174 |
| 19.40.4.2 | 6375 x 75 mm thread | Each | 404 |
| 19.40.4.3 | 7590 x 90 mm thread | Each | 524 |
| 19.40.4.4 | 90110 x 110 mm thread | Each | 732 |
| 19.40.5 | Straight Couplers | | |
| 19.40.5.1 | 5063 | Each | 640 |
| 19.40.5.2 | 6375 | Each | 770 |
| 19.40.5.3 | 7590 | Each | 1152 |
| 19.40.5.4 | 90110 | Each | 1563 |
| 19.40.6 | Reducers | | |
| 19.40.6.1 | 7590 x with all sizes | Each | 1124 |
| 19.40.6.2 | 90110 x with all sizes | Each | 1506 |
| 19.40.6.3 | FLOW CONTROL VALVE | | |
| 19.41 | Flow control valve threaded with SS-304 outward fitting in accordance with BS EN 120201 Part-3, suitable for drinking water supply 5 lpm, 10 lpm and 15 lpm capacity. | Each | 402 |

PART (B)

**INTAKEWELL,
WATER TREATMENT PLANTS,
ELEVATED SERVICE RESERVOIR,
GROUND SERVICE RESERVOIRS,
WATER METRES,
ANCILLARY ITEMS,
MIISCELLANESOUS ITEMS
AND
OUTDOOR TRANSFORMERS**

CHAPTER- XX

INTAKE WELL WORKS

CHAPTER - XX

INTAKE WELL WORKS

General Note:

1 **Scope**

2 The Specification covers the requirements for Survey, structural design & Construction of Intake Well.

3 **Intake Well:-**

It is a structure constructed in a surface water / near surface water to obtain water from the source. The intake structures are built to draw water from rivers, streams, lakes, and reservoirs etc.

4 **Selection for Intake Site :**

While taking a decision regarding the location of the intake site, the following points should be kept in view:-

4.1 The inflow point of the intake drawing water from a stream or a lake should be well below the water surface to prevent hydraulically wasteful air entrainment but sufficiently high enough from the bed to avoid entrapping of suspended solids.

4.2 The location should provide the most suitable quality of water available.

4.3 The site should have firm strata for good foundations.

4.4 The site should avoid the existence of currents that may endanger the safety of the structure or deposit silt against or on it.

4.5 The effect of floods at the proposed point should be studied and all precautions taken for the safety of the structure as well as safe working of the intake during floods

4.6 The distance from where the power is available should be considered.

4.7 The distance of pumping station from the proposed site of intake also deserves consideration.

4.8 In case of impounding reservoir, the intake should be located at the deepest point in reservoir, which is generally near the dam site, in order to take the optimum utility of the reservoir capacity.

5. **Surveys needed for intake well :-**

Following surveys shall have to be conducted for preparation of detailed drawings & designing of intake well

5.1 River gauging

5.2 Geological and soil investigation

5.3 Cross sectional survey

5.4 Contour survey of the area

- 5.5 Hydrological survey of the source
- 5.6 Catchment area survey (the catchment area of the source should be located on the map)
- 5.7 Fixing of maximum HFL etc
- 5.8 Sanitary survey.
 - 5.8.1 Sanitary surveys at regular, intervals at field management levels and inspections at supervisory management level should be conducted. The catchment area of the source should be located on the maps. Potential sources of pollution observed in the catchment should be marked. The type of pollution e.g. industrial/domestic waste discharges, wastes of animal origin and agricultural run-offs should be determined
 - 5.8.2 The reports of such survey should be promptly sent to the Pollution Control Authorities as well as water works authorities to promote corrective action. Procedure for monitoring of preventive action taken should be laid down and observed. An instant action plan for providing chlorination of raw-water should be available and brought into effect under such circumstances.
- 5.9 Measurement of flow.
 - 5.9.1 In cases of sources such as springs, rivers, canals, etc., there should be a permanent arrangement for recording daily flows near the intake works. Appropriate records in the form of graphs showing variation of flows in the source for each month in a year and for each year shall be maintained. Rain gauge stations should be established to record daily rainfall in the reservoir catchment and appropriate rainfall records should be built up and compared with discharges/ storages available. In case of reservoirs, the regime tables for filling and emptying of storages should be maintained for each year.
- 6. **Measurement:**
 - 6.1 All the measurement shall be recorded under the relevant item of the work.
 - 6.2 Generally the work of survey, design & construction of intake well is awarded on turnkey basis and payment is made on lump-sum basis as per payment schedule given in the tender.
- 7. **Rates**
 - 7.1 The rate shall include the cost of materials and labour involved in all the operations except for the items measured/ enumerated separately under clause 'Measurements', which shall be paid for separately.

INTAKEWELL WORKS

| Sr. No. | Item Description | Unit | Rate (in Rs.) |
|---------|--|------|---------------|
| 20.1 | Providing, constructing coffer dam in river basin / dam storages as per type design including excavation, filling, the middle portion with B. C. soil (in gunny bags if required). Providing impervious / semipervious materials on both side of B.C. soil (in gunny bags if required) including ramming, compacting to the satisfaction of Engineer-in-charge, till the completion of work including dismantling coffer dam after completion of works and disposing off the material as directed by theEngineer-in-charge. | Cum | 694 |
| | <p>Note :</p> <p>Pay line maximum- Top width payable shall be 2 mtr. And maximum payable side slopes shall be 1.5 Horizontal to 1 vertical, if the constructed top width of the side slopesare less, then the measurements at actual are payable. Extra top width or flatter slopes are not payabale Contractor is free to use ballies, plastic sheets, piles, pipes, CGI sheets for supporting hearting materials instead of impervious/ semipervious hearting materials for which no extra payments shall be payable. 30% payment shall be withheld for dismantling of coffer dam. This foot note shall appear in tender condition.</p> | | |
| 20.2 | Providing and fabricating at work shop, carting to site of work, including transport, loading, unloading, hoisting, lowering and setting out at actual site of well, sinking M.S. plate cutting edge. For R.C.C. well curb consisting of 350 mm M.S. plate, 10 mm thick, champhering at bottom. Cutting edge should be provided in pieces not less than 2 M in length. Each joint should be plain from outside and jointed by gusset plate 400 x 200x 12 mm thick M. S. plate with 12 nos. of20 mm dia. crurshank headed bolts (gusset plates 14mm from bottom so that 15mm side should be in contact with cutting edge with overlap of 300 mm joints. 16 mm dia bar should be welded to M.S. plate 200 mm | Kg | 86 |

| Sr. No. | Item Description | Unit | Rate (in Rs.) |
|---------|---|------|---------------|
| | below the top surface and length should be 1.8 M above plate with a bend 300 mm from plate surface including 3 coats of anticorrosive paint as directed by Engineer-in-charge. | | |
| 20.3 | Earth work in excavation of foundation for structures as per drawing and technical specification including setting out, construction of shoring and bracing, removal of stumps and other deleterious matter, dressing of sides and bottom and backfilling with approved material etc. and as per relevant clause of section 300 & 2100 | | |
| | Ordinary soil | | |
| | Up to 3 m depth | Cum | 144 |
| | Above 3.0 m to 6.0 m depth | Cum | 165 |
| | Above 6 m depth | Cum | 201 |
| 20.4 | Providing and filling puddle (selected good impervious clay) in Kolhapur type weirs in proper layers of 15 cm including watering, ramming and compaction, etc. complete with all leads and lifts. | Cum | 278 |
| 20.5 | Providing and filling around the Intake well boulders filling of selected variety and size of boulders including cost of all materials, labour, transportation, etc. complete with all leads and lifts. | Cum | 876 |
| 20.6 | Providing, and fixing 80 mm dia A.C./ P.V.C. pipe weep holes at 1.5 M c/c staggered including cost of all materials and labour involved with all leads and lifts etc. complete with all leads and lifts. | Rmt | 193 |
| 20.7 | Providing and fixing M.S. chaquered plate flooring of following thickness supported on M.S.angles (25 x 25 x 5 mm size) including welding, cutting and fabricating the plate to the required square or rounding shape, making holes in the plate, including providing and applying 3 coats of anticorrosive paint, etc. complete as directed by Engineer-in-charge. | | |
| | 6 mmthick | Sqm | 3706 |
| | 8 mmthick | Sqm | 4698 |

| Sr. No. | Item Description | Unit | Rate (in Rs.) |
|---------|--|----------|---------------|
| 20.8 | Providing at site of works ISI standard RCC slotted pipes of NP-3 class including cost of all central and local taxes, octroi, inspection, transportation, etc. complete including cost of RCC collar, etc.complete. | | |
| | 450 mmdia | RM | 3848 |
| | 600 mmdia | RM | 5985 |
| 20.9 | Lowering, laying and jointing RCC slotted pipes of following diameters including all leads and lifts, cost of jointing material, labour, etc. complete as directed by Engineer- in-charge. | | |
| | 450 mmdia 600 mmdia | RM RM | 216 287 |
| 20.10 | Lowering, laying and jointing CI 'B' class connecting mains with rubber gaskets including transportation of pipes from store to site of works, cost of jointing materials, cost of rubber gasket with all leads and lifts, etc. complete. | | |
| | 300 mm dia | RM | 296 |
| | 350 mm dia | RM | 361 |
| | 400 mm dia | RM | 439 |
| | 450 mm dia | RM | 464 |
| | 500 mm dia | RM | 494 |
| | 600 mm dia | RM | 689 |
| | 700 mm dia | RM | 903 |
| | 750 mm dia | RM | 1023 |
| 20.11 | Providing, lowering, laying and placing in position, shrouding material for porous pipe gallery / slotted pipe gallery/ trench gallery with all leads and lifts involved including transportation of materials to site of works, screening and washing of materials and placing in position with given section, etc. complete as directed by Engineer-in-charge. | | |

| Sr. No. | Item Description | Unit | Rate (in Rs.) |
|---------|--|------|---------------|
| | 40 mm pebbles | Cu.m | 1493 |
| | 12 mm to 20 mm pebbles | Cu.m | 1807 |
| | 6 mm to 12 mm pebbles | Cu.m | 2059 |
| | Coarse Sand (from river sand at site) | Cu.m | 900 |
| | Fine Sand (from river sand at site) | Cu.m | 1000 |
| 20.12 | Providing and fixing in position C.I./M.S. steps or 22 mm dia. MS bar steps with proper anchorage, etc. and providing and applying 3 coats of ant-corrosive paint, etc complete as directed by Engineer-in-charge. | No. | 454 |
| 20.13 | Providing and fixing M.S. sluice gates in position as per detailed drawing and specification including cost of all materials, abour, operating pedestal, connecting rod, painting with three coats of anti-corrosive paint, etc. complete as directed by Engineer-in charge. | Kg | 106 |
| 20.14 | Providing and fixing in position C.I./M.S. rose pieces in intake wells including cost of all materials and labour, painting with threecoats of anti-corrosive oil paint, etc.complete as directed by Engineer-in-charge. | Kg | 79 |
| 20.15 | Providing and spreading around the well 1 mm thick polyethylene sheet complete as directedby Engineer-in-charge. | Sq.m | 24 |
| 20.16 | Dewatering charges for estimation purpose for head works in river basin or dam | | |
| | Approach channel | RM | 5723 |
| | Intake well of 3 M dia | No | 76330 |
| | Inspection well of 2 M dia | No | 49149 |
| | Connecting main | RM | 4587 |
| | Jack well of 6 M dia | No. | 228977 |
| | Approach Bridge | RM | 771 |
| | Notes:- (i) The Contractor at his request may be allowed to start construction of masonry steining so as not to allow silting of well in coming mansoon and while paying masonary 25% amount shall be withheld and released only when excavation to the full depth is completed. | | |

| Sr. No. | Item Description | Unit | Rate (in Rs.) |
|---------|--|---------------------|-----------------------|
| | <p>(ii) "Dewatering":- Total dewatering charges are to be proposed in the tender as lump-sum amount and 75% is payable for excavation and 25 % is payable for construction of well/gallery. Out of 75 % excavation break shall be as under:- 25% for last 1 M depth. 20% for 2M depth which just above last 1M depth. 15% for 2M depth which just above last 3M depth. 15% for the rest of depth from water table level</p> <p>(iii) The provisions made for dewatering in the tender being on lump-sum basis, the same shall have to be reduced/ increased proportionately as the length of approach channel, connecting main or approach bridge reduces/ increases during actual execution. Condition No. 1 and 2 shall appear in Tender document.</p> | | |
| 20.17 | <p>Carrying out recuperation / Yield test for ascertaining the discharge of constructed well/ excavated profile as directed by Engineer - In-Charge. The test carried out by drawing down water from the well / profile below normal / subsoil water level upto full depth rise is recorded. The normal water level / subsoil water level / subsoil water level in the well / profile as well as strainer / suction level at pump as per design of W.S. Scheme shall be recorded prior to the test including cost of all materials, overload, labours etc. complete as directed.</p> <p>The test shall be carried out as per technical circular No. 2597 dt. 20.11.1997 and shall be carried out for 7 days.</p> | | |
| | <p>a) Lps more than 25000 b) Lps less than 25000</p> | <p>Day Day</p> | <p>2591 1865</p> |
| 20.18 | <p>Providing and laying HDPE Geo-membrane sheet of following thickness 100% acid, alkali proof, 100% rain forced sealing quality, every joints electronically welded, as per relevant IS specification & placing in proper position on prepared bed on foundation/ embankment with welding the joints of sheet using hot sedge and</p> | | |

| Sr. No. | Item Description | Unit | Rate (in Rs.) |
|---------|--|----------|---------------|
| | extrusion welding techniques according to the liner manufacturers specifications at ambient temperatures of 5 ^o C to 45 ^o C including all taxes & labour for jointing and placing etc. complete. | | |
| | 500 micron | Per Sqm. | 259 |
| | 250 micron | Per Sqm. | 179 |
| 20.19 | Providing and fixing in position copper lightning conductor including copper rod of 20 mm dia as per upper terminal 1.5 M long with a knob at end and with conical spike at top, copper tape conductor 20x 3 mm size, copper earth plate of 3 mm thick and 0.81 sqm. in area, clamps at 1 M centre to centre including, necessary excavation, laying and fixing the conductor, providing and fixing 40 mm G.I pipe upto 3 M height from ground and 0.5 M below ground including making all connections, filling the earthing pit with charcoal, salt, etc. and refilling and watering, etc. complete as per specifications laid down in relevant I.S. codes. | | |
| | (i) For Tape of 10M length | No | 11250 |
| | (i) Rebate / Extra rate per metre length or part thereof | Mtr | 294 |
| 20.20 | Providing and applying outside weather coats and inside epoxy paint of approved make (as desired by Engineer-in-charge) to concrete surface of Intake well / other structure including cleaning the surface by scrapping and air blowers to the satisfaction of Engineer-in-charge, necessary scaffolding, etc complete with all leads and lifts and giving satisfactory hydraulic test for water tightness as per I.S. code: | | |
| | a) For new surfaces - Two coats. | Sq.m | 640 |
| | b) For old surfaces - Two coats. | Sq.m | 721 |

| Sr. No. | Item Description | Unit | Rate (in Rs.) |
|---------|---|------|------------------------|
| 20.21 | <p>Detailed physical survey, sanitary survey, Hydrological survey, Geological investigation including trial bores for soil investigation / test for preparation of river cross section, fixing of HFL, structural design & estimation for intake wall, approach bridge, coffer dam etc. complete as directed by the Engineer-in-charge in / near, river / stream / dam / lake / spring / canal etc. collection of data regarding design of complete item of intake well from relevant department etc. all level will be with reference to mean sea level including following work:-</p> <p>(i) Preparation of Contour plan general arrangement drawing, layout of site, cross-section of site on proper scale as directed by the department.</p> <p>(ii) Architectural/ Structural drawing having following items :-</p> <p>(a) Layout plan. Elevation, cross-section i/c details of cofferdam, approach bridge, Intake well, and different small element relevant to complete item of Intake well.</p> <p>(b) Preparation of estimate on prevailing schedule of rates, architectural drawing / structural drawing for technical clearance from proper competent sanctioning authority state government or it may be central government department. Complete set of drawing and estimate will be submitted in 6 sets.</p> | Job | 5 % Estimated cost |
| 20.22 | <p>Provision of (i) Gantry crane for lifting of machineries, single girder hand operated, circular travelling gantry of capacity minimum 5 T, operational at motor floor, and (ii) Mud pump for removal of deposited sludge from bottom floor . The cost of these items shall be included under mechanical and electrical works.</p> | Job | 5 % of estimated cost. |

CHAPTER- XXI

WATER TREATMENT PLANTS

CHAPTER-XXI

WATER TREATMENT PLANT

1. CONVENTIONAL WTP

- 1.1 Designing(aesthetically),providingandconstructingand commissioning conventionalWater Treatment Plant consisting of all Civil,works including cost of Providing and applyingEpoxy paint to inside surface of water retainingstructures in contact with chlorine and providinganti - termite treatment to entire structure belowGround level, ceramic tiles for flooring, Acrylicemulsion with silicon additives paint from outside, stainless steel railing, Mechanical and Electrical components of various sub-works asgiven below: including necessary hydraulictesting, structural testing equipment testing, trialrun for a period of 3 months, etc. complete asdirected by Engineer-in-charge (turn-key job).
- 1.2 **Aeration Fountain:**
Plan area not less than 1.25 square meter per MLD
- 1.3 **Ventury Flume:**
With necessary devices, consisting of simple mechanical indicator. (Pedestal type gauge)
- 1.4 **Flash Mixer:**
Rapid mixing device, detention time 60 seconds to give velocity gradient 300 to 400 sec-1 vane mixer type confirming to I.S. 7090 of 1985.
- 1.5 **Flocculator:**
Confirming to I.S. 7208 of 1974 (Type-C) withdetention period of 30 minutes.
- 1.6 **Clarifier:**
Horizontal flow circular tank, detention period 2-5hours, overflow rate 30 cubic metre per squaremetre per day (to be specified), Weir loading notmore than 300 cubic metre per metre per day, withmechanical sludge scraper conforming to I.S. No.10313 -1982 with necessary inlet arrangements.
- 1.7 **Rapid Sand Filters and Filter House**
Filter designed for filtration rate of 4800 litersper square metre per hour for normal run and itshall not exceed 6000 liters per square metre perhour when one bed is undermaintenance,minimum 2 beds for plant upto 10 MLD, for larger plants as specified, filters to be located in filter house with roof slab, pipe gallery and platform minimum 5.5 metre in width with constant rate

filtration or declining rate filtration. All valve shall be glandless.

- 1.7.1 **Filter Sand** : Effective size 0.45 to 0.70 mm, uniformity coefficient not more than 1.7, nor less than 1.3, depth of water over sand 0.75 M, free board 50 cm, gravel 0.45 M in depth, sand and gravel conforming to I.S. 849 (i)-77, back wash by air wash, standard appurtenances
- 1.7.2 **Wash Water Tank**
Capacity to be specified and suitable to supply water to wash specified number of filter beds at a time 12 minutes @ 600 lit/sqm/min under a head of 12m at under drain.
- 1.7.3 **Wash WaterPumps**
Capacity to fill water tank in 1 hour with 100 % standby.
- 1.7.4 **Air Blowers**
Capable of delivering 600 LMP per square metre of free air, of filter area at 0.4 kg/square cm at the underdrains (100% stand by) for period of 5 min. Air blowers shall be adopted for WTP having capacity more than 3 mld only. Below 3 mld capacity, Air blowers shall not be adopted.
- 1.8 **Chemical House in Two Storied**
- 1.8.1 Ground floor to accommodate 7 days alum requirement and sundry storage (Minimum 4 m height)
- 1.8.2 First floor to accommodate alum and lime tanks. Chain pulley block etc. (min. 5 mheight) shall be provided.
- 1.9 **Solutiontanks**
Minimum 3 tanks (one for preparation. second for dosing and third as standby), each tank capable of giving 8 hours maximum dose without interruption, minimum free board 0.30 M, trays for dissolving, level indicator, mechanical agitation devices, solution feed and drain lines, solution feed device (constant head device, strength of solution upto 10% only) conforming to I.S. 9222part-I/1979.
- 1.10 **Pure Water Sump and Pump House**
- 1.11 **Capacity of sump**
One hour of designed flow.
- 1.12 **Pump House**
Pump house of required size over the sump or by the side.

1.13 **Store House**

Suitable for alum storage of three months and 7 days temporary storage, 7 days TCL requirement in manson with 20 % extra capacity for other sundry articles.

1.14 **Vacuum feed type chlorinators**

1.14.1 Make to be approved by PHED CG.
Confirming to I.S. 10533 - A Part-II 1983.

1.14.2 Rate of withdrawal of chlorine from container depends upon the size of container and the surrounding temperature, for guidance table given below may be followed.

| Temperature °C | Chlorine discharge per day in Kg. | | |
|-------------------|-----------------------------------|---------|---------------------|
| | Cylinders | | Tonner Container |
| | (45 Kg) | (67 Kg) | |
| 10 | 6.35 | 9.50 | 110 |
| 15 | 10.75 | 16.10 | 130 |
| 20 | 14.50 | 21.54 | 254 |
| 27 and above | 18.70 | 28.12 | 315 |

1.14.3 When the gas discharge rate from a single container does not meet the requirements, two or more containers can be connected to a manifold and discharge simultaneously. It is advisable not to couple more than 4 containers to a manifold.

1.15 **Chlorinator Equipment and Container room**

- Handling, storage and safety shall confirm to I.S. 10553 Part - I 1983.
- 100% Standby shall be provided.
- 100 kg chlorine cylinder for capacity upto 5 mld and chlorine tonner for capacity above 5 mld.

1.16 **By pass arrangements:**

- By passing all units of T.P.
- By passing flash mixer, clariflocculator.
- By passing flash mixer, clariflocculator & filterunits
- Only CI pipes shall be provided in above by passing arrangements.

1.17 **Disposal of waste/sludge from WTP:**

Safe disposal arrangement shall be provided. This provision shall be comprised of RCC NP-2 pipe of minimum 250mm dia with manholes at an

interval of 30m C/C. The manholes shall be of RCC chamber with RCC cover. The waste water/sludge disposal arrangements upto length of 100m is included in the Para 19.4- Notes (under item No. 8) and it should be safely disposed to nearby nallah.

- 1.18 **Recycling of Waste Water Arrangement**
- WTP of capacity 5 MLD and above, it is mandatory to provide backwash water recycle arrangements which includes sump, pumping machinery, rising main etc.complete.
 - However, provision of the same may also be made in the WTP of lower capacity.
 - The cost of recycling arrangement is not included in the cost of WTP.
- 1.19 **Electrical installation.**
Both internal and external including entire plant area.
- 1.20 **Laboratory equipment.**
As per requirement (As per provisions made in the CPHEEO Manual-1999–duly amended)
- 1.20 **Sanitary blocks.**
Carpet area-15 square metre minimum upto 25Mld and 25 square metre above 25 Mld.
- 1.21 **Administrative block and internal road:**
To accommodate office room. chlorine room,laboratory room, panel board room, blower roometc. and WBM road to connect all units frommain gate of plot.
- 1.22 **Rates**
Rates givenbelow are inclusive of uplift pressure if any and dewatering during entire work. These rates are applicable for seismic zones-2,3 and 4.
- 1.23 **RCC Structures**
All RCC structures shall be constructed in M-30
- 1.24 **Overloading Capacity:**
Allpipesandconduitschannelwith25%overloading capacity.All the structural steel work / fabrications are tobe provided with application of Hot Dip Zinccoatingaccording tospecificationsasperIS: 4759:1996 (Reaffirmed 2006)
- 1.25 All the treatment units e.g. Cascade aerator, Flash mixture, Clariflocculator, Filtration units should be connected with walkway of 1.2 m wide suitably have provision of 25 mm dia. GI (medium class) railings and railing post.
- 1.26 **Notes:**

1.26.1 All the conditions from 19.1.1 to 19.1.21 shall form a part and partial of the tender document and must be incorporated in the draft NIT of conventional WTP.

1.26.2 **This USOR contains the rates of all the items without GST. No claims against GST shall be entertained at any level. GST shall be paid by the Agency/ Contractor directly to the concerning department. Howerer, All the estimates prepared on this USOR will include GST, as an extra amount as per prevailing rates on the sum of the estimate to arrive at the gross amount.**

1.27 **Rates for Conventional Treatment Plants**

| Sr. No. | Capacity in Mld | Unit | Rate (Rs in Lakhs) | |
|---------|--|---------|--------------------|---------|
| 21.1.1 | Cost of 1 MLD Treatment Plant | Job | | 57.69 |
| 21.1.2 | Add for capacity above 1 MLD upto 5MLD | Per MLD | 32.58 | |
| 21.1.3 | Cost of 5 MLD Treatment Plant | Job | | 188.01 |
| 21.1.4 | Add for capacity above 5 MLD upto 10 MLD | Per MLD | 28.23 | |
| 21.1.5 | Cost of 10 MLD Treatment Plant | Job | | 329.17 |
| 21.1.6 | Add for capacity above 10 MLD upto 20 MLD | Per MLD | 19.76 | |
| 21.1.7 | Cost of 20 MLD Treatment Plant | Job | | 526.80 |
| 21.1.8 | Add for capacity above 20 MLD upto 50 MLD | Per MLD | 16.80 | |
| 21.1.9 | Cost of 50 MLD Treatment Plant | Job | | 1030.88 |
| 21.1.10 | Add for capacity above 50 MLD upto 100 MLD | Per MLD | 14.28 | |
| 21.1.11 | Cost of 100 MLD Treatment Plant | Job | | 1744.77 |
| 21.1.12 | Add for capacity above 100 MLD | Per MLD | 8.42 | |
| 21.1.13 | Cost of 150 MLD Treatment Plant | Job | | 2165.77 |

2. UNCONVENTIONAL WTP

- .2.1 Designing (structurally & aesthetically), providing and constructing high rate Unconventional Water Treatment Plant i.e. Simplified Water Treatment Plants consisting of Civil Works, Electrical and Mechanical Works as static mixture, flocculation tank, lamella clarifier with facility of sludge recirculation, multi-grade filter with best quality filter charging materials including all fittings like valve and other special fittings, filter feed pumps, clarified water tank, treated water sump well with pump house, chemical dosing pumps and chemical mixing system for alum, lime & polymer with administrative cum laboratory building, chemical house cum dosing system room, foundations, MCC panel, cabling, laboratory items and applying epoxy paint to inside & outside surface of WTP, necessary testing and free trial run for 03 Months etc. complete as directed by Engineer-in-charge .
- 2.2 NaOCl dosing in feed water line which works as an oxidizing agent and a very effective disinfection also and kills the toxic microbes and bacteria in the **water**. This does not allow algae formation in clarifier zone. Also, **aeration** takes place when the water leaves top of each place though a pair of circular openings in the adjustable weir plate located along each side of the clarifier.
- 2.3 There is an inlet pipe provided with chemical dosing pumps, dosing tanks and chemical mixing systems for Alum, Lime, Polymer & Sodium Hypochloride.
- 2.4 **Static Mixer** in the inlet piping.
- 2.5 **Flocculator Tank**- Designing and fabricating of M.S. SMFT tank of capacity 20 minutes of designed flow with slow speed agitator, motor and fan. A static mixer cum flocculation tank is provided and water to be treated is fed to the bottom of the flash mix compartment where it is intimately mixed. In this compartment, formation of flocs continues and flocculation is complete. Water containing the floc, passed into the lamella clarifier.
- 2.6 **Lamella Clarifier** - Designing, fabricating and construct the lamella clarifier with removable FRP plates consists of inclined overlapping plates, which are arranged to form a separate sedimentation chamber or the cells between each pair of adjacent plates. The overlapping additive projected area of several plates is a factor of increased surface settling area proportion to the number of plates used.
- 2.6.1 The inlet flow is divided and enters the tower part of each sedimentation cell from its two opposite sides. As the water is displaced upward in smooth, gently flow, the suspended solids coalesce to form precipitates

which settle in the chambers on the lower portion of each lamella plate. Influent water flows upwards over the plates. The deposited precipitates increase in size until they slide or roll down the inclined surface of the plates. This is then collected in the hopper provided at the bottom of the separator.

- 2.7 Clarified Water Storage Tank** of capacity equal to 12 minutes of designed quantity of filtered water in an hour is provided to feed water to multi-grade pressure sand filter with the help of pumps on ground level.
- 2.8 Clarified Water Filter Feed pumps** with 100% standby and canopy.
- 2.9 Multigrade Pressure Sand Filter** - The clarified water, which comes out from the Lamella Clarifier, will enter Multigrade Pressure Sand Filter with the help of pump to remove the suspended solids. This is the special type of filter developed that offers coarse as well as deep bed filtration and it can operate on very high specific velocity. There are two grades of sand in the filter, which increase the porosity of the filtering media. Once the pressure drop across the filter bed becomes 1 Kg/cm² back washing of the filter media is to be carried out. During backwash the specific velocity is higher so that the dirt particles that have been accumulated in the filter bed can be taken out from the filter. MS pressure sand filter is installed in open area.
- 2.10 Treated Water Tank** (sump) capacity equal to 1 hour pumping capacity of WTP.
- 2.11 Treated water pump house.**
- Two electronic dosing pumps are provided for lime solution preparation tank with agitator and a day tank in inlet line.
 - Two electronic dosing pumps are provided for alum solution preparation tank with agitator and a day tank in inlet line.
 - Two electronic dosing pumps are provided for polymer solution preparation tank with agitator and a day tank in inlet line.
 - Four electronic dosing pumps are provided for sodium hypochlorite for pre-treatment and post treatment.
 - Recirculation arrangement in clarifier to static mixture cum flocculator for sludge recirculation.
 - Drainage arrangements.
 - Flow meter at the inlet line of system and flow control valve.
 - MCC panel and cabling works for motors, agitators, dosing systems, power cabling & earthing.
 - External and internal electrification.
- 2.12 Laboratory equipments:**
- Chlorine test kit, pH digital meter, turbidity digital meter, jar test.
 - Chemical house cum dosing system room.
 - Office cum lab room.

- Sanitary block with necessary water supply and drainage arrangement.
- All equipments and civil work including office cum lab, chemical house, clarified water tank, treated water tank, pump house and all foundations.

2.13 All RCC structures shall be constructed in M-30.

2.14 **Rates:**

2.14.1 These rates are applicable for seismic zones 2,3and 4

2.14.2 **This USOR contains the rates of all the items without GST. No claims against GST shall be entertained at any level. GST shall be paid by the Agency/ Contractor directly to the concerning department. Howerer, All the estimates prepared on this USOR will include GST, as an extra amount as per prevailing rates on the sum of the estimate to arrive at the gross amount.**

2.15 **Rates for Un-Conventional Treatment Plants**

| Sr. No. | Capacity in MLD | Unit | Rate (Rs in Lakhs) | |
|---------|---|---------|--------------------|--------|
| 21.2.1 | Fixed cost for 1 MLD | Job | | 61.97 |
| 21.2.2 | Add for capacity above 1 MLD upto 2 MLD | Per MLD | 27.89 | |
| 21.2.3 | Cost of 2 MLD Treatment Plant | Job | | 89.86 |
| 21.2.4 | Add for capacity above 2 MLD upto 5 MLD | Per MLD | 23.71 | |
| 21.2.5 | Cost of 5 MLD Treatment Plant | Job | | 160.99 |
| 21.2.6 | Add for capacity above 5 MLD | Per MLD | 20.14 | |
| 21.2.7 | Cost of 10 MLD Treatment Plant | Job | | 261.69 |
| 21.2.8 | Add for capacity above 10 MLD | Per MLD | 17.13 | |

3. PACKAGE WATER TREATMENT PLANT

3.1 Designing (aesthetically), providing, fabricating, Package Water Treatment Plant. At the shop, transporting to site, installing, testing and commissioning at the site, giving necessary one month's free test and trial run with guarantee for one year, etc. complete.

3.2 Prefabricated Package Water Treatment Plant comprising following:-

3.3 **Rapid mixing channel** in M.S. sheets and M.S. baffle.

- 3.4 **Flocculator** not less than 10 minutes detention, in M.S. prefabricated box, flocculation being achieved either by glass pebbles of graded size or PVC tetrapod or equivalent arrangement to ensure good flocformation.
- 3.5 **Plate or tube settlers** of not less than 30 minutes detention, in M.S. prefabricated box, plates / tubes mounted in the settler basin with inclination of not less than 60 degree to horizontal.
- 3.6 **Rapid sand gravity filter** in M. S. prefabricated box with filter sand not less than 500 mm thick, supported on false floor below with polypropylene nozzles spaced at not more than 500 mm centres in either direction
- 3.7 **Backwashing, inlet facilities** only shall be provided. Department shall provide either ESR giving 8 to 10 M head at filter nozzles or backwash pump, having flow rate of 0.6 Cum per minute per square metre of filter bed. (Limit upto 5.0 M. from W.T.P. face)
- 3.8 **All civil works** for foundation, consisting of raised RCC platform above G.L. or walls in B.B. masonry or UCR masonry shall be provided as per needs at site.
- 3.9 **Bypass in the form of pipes or M.S. channels:** included in the design, effecting bypass of such new tank and filter individually or both. (Limit upto 5.0 M. from W.T.P. face) The entire
- 3.10 **M.S. fabricated tank** provided with FRP lining (5 mm thick) to inside face in contact with water epoxy painting- two coats with one coat of primer on outside. The thickness of plates employed shall not be less than 6 mm
- 3.11 **Alum dosing and mixing arrangements** to be provided in twin tanks, each of 8 hours capacity, capable of importing dose of 20 ppm with 5% solution. The alum tanks provided with a dose in steps of 5 ppm and entire unit mounted on the top of flocculator / settler box, in the form of prefabricated structure, with access platform and ladder. Alum boxes with FRP lining (5 mm thick) inside and epoxy paint two coats with one coat of primer on outside.
- 3.12 **Both flocculator and settling basins** provided with hopper bottom with slope not less than 45 degrees to the horizontal drain pipes and valves provided to both flocculator and settling basin.
- 3.13 **Flow ratings** to conform following parameters: Velocities in channels not to exceed 0.6 M./Second. Velocities in filter outlet pipes and valves not

to exceed 1 M./Second. Velocities in interconnecting pipe and controls not to exceed 1M./Second. Backwash with air Not required.

- 3.14 **Backwash with water:** Not less than 0.6 M./Sqm. of filter bed area in filter box.
- 3.15 Free board for all units not less than 300 mm
- 3.16 Depending upon the capacity required for the scheme, one of the above capacity should be considered
- 3.17 **This USOR contains the rates of all the items without GST. No claims against GST shall be entertained at any level. GST shall be paid by the Agency/ Contractor directly to the concerning department. However, All the estimates prepared on this USOR will include GST, as an extra amount as per prevailing rates on the sum of the estimate to arrive at the gross amount.**

3.18 Rates for Un-Conventional Treatment Plants

| Sr. No. | Capacity in Mld | Unit | Rate (Rs in Lakhs) |
|---------|--------------------------|------|--------------------|
| 21.3.1 | 21 Cum / Hr. (0.50 MLD) | Each | 29.67 |
| 21.3.2 | 34 Cum / Hr. (0.80 MLD) | Each | 36.42 |
| 21.3.3 | 42 Cum / Hr. (1.00 MLD) | Each | 40.89 |
| 21.3.4 | 63 Cum / Hr. (1.50 MLD) | Each | 51.39 |
| 21.3.5 | 83 Cum / Hr. (2.00 MLD) | Each | 60.78 |
| 21.3.6 | 125 Cum / Hr. (3.00 MLD) | Each | 78.37 |

4.

Note:

The rates computed in the analysis of water treatment plant and sewage treatment plant do not include the cost of (i) Out sourcing for consultancy (ii) detailed survey, (iii) soil investigation, (iv) detailed hydraulic, (v) structural designing, (vi) Lab articles, glass wares and equipments, (vii) other specifically required articles to construct the plants. (viii) disposal of sludge up to nearest natural drainage system (ix) external development like external and internal electrification, (x) cost of chemicals, man powers etc during trial run of 3 months, and (xi) cost of O &M for subsequent another 9 months, (xii) If required, suitable provision for PLC-SCADA system may also be included. Since, the above said charges has to be either owned by the agency or by the department therefore, it is necessary to include cost of these charges in the preparation of estimate. The tentative provisions for above

said items may be considered as under:-

| Sr. No. | Description of items | Unit | Upto 5 MLD | Above 5 and upto10 MLD | Above 10 and up to25 MLD |
|----------------|--|-------------|-------------------|-------------------------------|---------------------------------|
| 1 | Out sourcing for consultancy | LS | 0.30% | 0.20% | 0.10% |
| 2 | Detailed survey, | LS | 0.30% | 0.20% | 0.10% |
| 3 | Soil investigation, | LS | 0.30% | 0.20% | 0.10% |
| 4 | Detailed hydraulic design | LS | 0.60% | 0.40% | 0.20% |
| 5 | Structural designing, | LS | 0.90% | 0.60% | 0.30% |
| 6 | Lab articles, glass wares and equipments, | LS | 3.00% | 2.00% | 1.00% |
| 7 | Other specifically required articles to construct the plants. | LS | 0.30% | 0.20% | 0.10% |
| 8 | Disposal of sludge up to nearest natural drainage system | LS | 4.50% | 2.50% | 1.50% |
| 9 | External development like external and internal electrification, | LS | 1.50% | 1.00% | 0.50% |
| 10 | Cost of chemicals, man powers etc. during trial run of 3 months, | LS | 1.50% | 1.00% | 0.50% |
| 11 | Cost of O &M for subsequent another 9 months, | LS | 6.00% | 3.20% | 2.00% |
| 12 | If required, suitable provision for PLC-SCADA | LS | 4.50% | 3.00% | 1.50% |

CHAPTER- XXII

SEWAGE TREATMENT

PLANTS

CHAPTER-XXII
SEWAGE TREATMENT PLANT

General Notes:-

1.0 SEWAGE TREATMENT PLANT

1.1 Designing (aesthetically), providing, and constructing and giving satisfactory trials of **Sewage Treatment Plant** consisting of receiving chamber, screen chamber, grit chamber, measuring flume, distribution chamber with primary and secondary treatment, etc. as detailed below, administration block of suitable size including allied units for waste disposal with all civil and mechanical works involved, etc. complete.

1.2 **This USOR contains the rates of all the items without GST. No claims against GST shall be entertained at any level. GST shall be paid by the Agency/ Contractor directly to the concerning department. Howerer, All the estimates prepared on this USOR will include GST, as an extra amount as per prevailing rates on the sum of the estimate to arrive at the gross amount.**

1.3 Rates for Sewage Treatment Plants

| Sr. No. | Capacity in MLD | Unit | Rate (Rs in Lakhs) | |
|---------|---|---------|--------------------|---------|
| 22.1.1 | Per MLD cost and upto 10 MLD | Per MLD | 58.99 | |
| 22.1.2 | Cost of 10 MLD Plant | Job | | 589.90 |
| 22.1.3 | Add for capacity above 10 MLD upto 20 MLD | Per MLD | 51.61 | |
| 22.1.4 | Cost of 20 MLD Plant | Job | | 1106.05 |
| 22.1.5 | Add for capacity above 20 MLD | Per MLD | 44.24 | |

2.0 MODERNISED SEWAGE TREATMENT PLANT

2.1 Designing (Aesthetically) Providing and constructing, hydraulic testing commissioning and giving satisfactory trials of modernised sewage treatment plant consisting of inlet chamber, screen chamber, Detritus tanks, Parshall flume, primary settling tanks, Aeration tanks, Secondary settling tanks, Sludge Sump and Pump House ,Sludge Thickner, Primary digester , Secondary digester, SST Sump and Pump house, Chlorine contact tank, Chlorinators, Chlorinator room, sump cum blending tank, PST sludge sump cum blending tank, Pump house, Sludge Centrifuge, gas holder, necessary piping work with

required valves, gates, drains, pathways, Administrative Building cum Laboratory, Laboratory equipments, tools and plants, Spare parts etc. complete as turnkey job with all involved civil electrical and mechanical works inclusive of following items, units as per detailed specification for civil, Electrical and Mechanical Components with all duties etc. complete.

2.2 **Inlet Chamber:**

Designing, providing and constructing R.C.C. (M:30) Inlet chamber designed for the peak flow 2 DWF including necessary excavation in all types of strata including walkway around the periphery. Each compartment will have phosphor bronze, steel gate with extension rod, head stock, operating wheel, G.I. Pipe railing etc. The work includes providing and making necessary arrangements to connect the flow to screen chamber by approach channel as directed and as per specifications

2.3 **Screen Chambers:**

Designing, providing and constructing and testing commissioning screen chamber, designed for average 1DWF & maximum 2 DWF in RCC (M-30), including inlet pipe/Channel from inlet chamber outlet, pipe/channel to detritus tank, free board of 0.50 m minimum, RCC walkway 1.2M wide with G.I. Pipe railing. RCC stair case of 1.2 m width from G.L. to screen chamber.

2.4 **Detritus Tank:**

Designing, providing and constructing continuously grit removal type of Detritus Tank, mechanically operated in RCC (M-30) capable of removing 100% 0.20mm size particle and above, having specific gravity 2.30, designed for one peak 2 DWF with suitable arrangement of separation of grit from putrescible solids including providing and making necessary arrangement of JB-1. inlet and outlet channels of required sizes as may be required to connect the flow to parshall flume etc. complete including hydraulic testing for water tightness of the structure having minimum free board of 0.30 m, washout arrangement to grit chamber and platform 1.20m wide RCC walkway with G.I. pipe hand railing shall be provided. A pit for collecting grit conveyed by conveyor shall be provided. It should be suitable to handle the grit for carting. All arrangements shall be as per detailed specifications and as directed.

2.5 **Parshall Flume:**

Designing, Providing and constructing Parshall Flume Channel in RCC(M-30) for measuring quantity of sewage received at the treatment works, max flow of 2 DWF and minimum flow of 1/2 DWF including providing and making necessary arrangement of approach channel as may be required to connect the flow having minimum velocity of 0.3m per second to Distribution Box (DB-1)

The unit shall be provided with walkway & RCC staircase having width of 1.20 m each etc. complete, including hydraulic testing for water tightness of the civil structure having free board of 0.6 m including electrically operated, flow indicating and flow integrating devices having a standby of float operated ROF meter. All arrangements as per specifications.

2.6 **Primary Settling Tanks with Equipments:**

Designing, providing, constructing and hydraulic testing in RCC (M-30) water tight Primary Settling Tanks of 1 DWF capacity with feed chamber sludge and effluent chamber, base adequately supported providing 1.20m wide clear peripheral and approach walkway interconnecting C.I. double flanged pipes from feed chamber of the clarifier distribution well grouting wherever necessary, including foundation etc. as per specifications water depth at outer side shall be minimum 3.0 meters, weir loading shall not be greater than 125 cum DMF for average flow Bottom slope shall be 1:12

The floor of clarifier shall have 40 mm thick (min.) screed course of cement grout of mix in C.M. 1:2 Detention period shall be 2.25 hrs. dispersion box and stiffened weir plate made of mild steel plate not less than 8 mm thick, anti-corrosive epoxy paint on both faces shall be provided Minimum free board of 0.50 m. be provided it includes inlet pipe from distribution chamber, central shaft inlet baffle outlet chamber, Scum remover, skimming device, scum chamber, connecting channel from PST outlet chamber to DB-2 as per detailed specifications.

2.7 **Aeration Tank:**

Designing, providing and constructing in RCC mix (M-30) Aeration Tank in compartments to handle combined flow of 1 DWF, incoming flow and recirculation flow including construction of inlet, outlet and distribution chamber DB-3 and providing 1.20m wide clear peripheral and approach walkways, expansion joints wherever necessary, including foundation etc. as per specifications. Peak factor shall be 2, F/M ratio shall be 0.40, low speed aerator speed between 20 to 100 RPM recirculation flow @ 50% and free board 0.60 m Depth, (SWD) 3.50 m minimum D.O. level at A.T. 2 Mg/Lit, MLVSS concentration shall be 2500 Mg/Lit and MLVSS concentration shall be 2000 Mg/Lit, HRT shall be 4 to 6 hours and STR 6-8 days. It should have compartments for washing, oxygen transfer capacity of mechanical aerator shall not be less than 1.5 Kg/KWH, BOD of effluent 20 mg/lit with input to aerator 0.15 to 0.30 Kwh/1000 cum. of Aeration tank. All related works shall be as per detailed specifications.

2.8 **Secondary Settling Tanks with Equipments:**

Designing, providing & constructing in RCC (M-30) water tight secondary

settling tank having detention period 2 hours and SWD shall be 4.20 meter. The effluent BOD & SS from the secondary clarifier shall not be more than 20 Mg/lit and 30 mg/lit respectively. It should be hydraulically tested, bottom floor slope of 1:12 and free board of 0.60 m minimum Dispersion box shall be made of Mild Steel plate not less than 8 mm thick with anticorrosive epoxy paint from both faces and well stiffened The sewage admitted at the centre flowing upward and outwards towards periphery be slowly and continuously collected towards a convenient discharge point near centre by a rotating wheel arm. The Clarifier will be completed with end drive half rotating bridge, structural steel rake, over flow weir, walkway diffuser, over load alarms, having push buttons, starters for the clarifier, walkway and the suitable sludge withdrawing arrangement with flush valve capable of withdrawing moisture content not more than 97% to 98%, slorotating sludge scrapper mechanism fitted with squeezes including providing and making necessary arrangement to connect the flow to outlet chamber (DB-4) then the gravity mains for final disposal and as per detailed specifications and obligatory provision. All other arrangements shall be as per detailed specifications

2.9 **Sludge Thickner with Equipments**

Designing providing and constructing water tight of Sludge Thickner (Gravity type) including foundation in RCC (M-30) with inlet and outlet chamber influent well, inlet and outlet pipes, with sludge pit and sludge removal arrangement, grouting wherever necessary with walkway all-around of 1.20 m width G.I. pipe railing interconnecting CI pipes all complete as per specifications Detention time 24 hours. SWD shall be 4.25 metre with necessary fixed bridge scraper arrangement as per detailed specifications and necessary inlet and outlet arrangement. All other arrangement as per detailed specifications.

2.10 **Primary Digester with mixer equipment (Fixed Cover)**

Designing, providing and constructing unit of water tight and gas tight Primary Digester suitable for 1 DWF plant and complete with pipe gallery, building, staircase for access from dome of digester into inside staircase, walkways at springing levels etc. walls and base slab being in RCC M-300, domes in structural concrete including providing burners and civil works for gas collection, grouting wherever necessary etc. complete as per specifications. It should be designed for min 90 C and max. 450C. and minimum detention time of 30 days, water depth shall not be more than 8.5m free board shall be 0.6m with inlet and outlet arrangement of D.I. flanged pipes including giving hydraulic testing and air tightness testing. The item includes providing works for collecting Gas and Gasburner as per specification.

2.11 **Secondary Digester with equipment (Fixed cover)**

Designing, providing and constructing including foundation unit of watertight and gastight Secondary Digester to deal with 1 DWF complete with pipe gallery, building, staircase for access from dome of digester into inside, staircase to

walkways at springing levels etc., Walls and base slab and domes being in RCC M-30, providing arrangement for digested sludge from digesters to centrifuge, providing burners and civil works for gas collection grouting wherever necessary etc. complete as per specifications and obligatory provision All other arrangements as per detailed specifications.

2.12 **S.S.T. Sump & Pump House with recirculation Pumps and Sludge Pumps to Digester:**

Designing, providing & constructing Sump & Pump house of requisite capacity with ceiling height not less than 6.M., Sludge stream for recirculation to aeration tank & excess sludge to SCBT, including C.I. Piping to carry this flow to sump as per detailed specification & as directed by Engineer-in-charge.

2.13 **Chlorine Contact Tank:**

Designing, providing and constructing Chlorine Contact chamber of adequate capacity to deal with 1 DWF. Average flow. The chlorine contact tank should be of 30 minutes capacity during average flow to achieve 99.99% coliform reduction. Chlorine dose shall be maintained as per standard provisions including provisions including designing, providing and constructing water supply arrangement for chlorination, including providing dewatering and by-pass arrangements jointing to final effluent main and outlet weir etc complete. The effluent quality should match with the standards laid down by Maharashtra Water pollution Control Board and as per the obligatory provision and detailed specifications and as directed by Engineer-in-charge.

2.14 **Chlorinator and Chlorinator Room/ Tonner Room:**

Designing, providing and constructing chlorinators vacuum type 2 Nos each having capacity of 10 Kg/Hr as per obligatory provisions and detailed specifications with necessary provision of chlorinator room having floor area not less than 30 Sqmt.including automatic residual chlorine controller with actuator and residual chlorine analyser including cost of chlorine cylinder, piping, valves, measuring and controlling equipments, safety devices, lifting equipments, etc. complete as per I.S -10553 (PartII) 1982.The tonner room should have 3 MT capacity crane for loading and unloading facility. Tonner storage should distinctly isolated and should be for minimum 10 Tonners space and arrangements as per gas laws 1981 and factory act shall be provided and all other matching amenities be provided, 5 MT gantry shall be provided for full length of Tonner room at 6 m height from floor level, with /outlet chamber and treated effluent outlet channel etc. complete as per detailed specifications.

2.15 **Sump cum Blending Tank (SCBT)**

Designing providing and constructing sump cum blending tank of appropriate size and detention time with free board of 0.60 m. The slope of floor 1:4 with suction pit at the center as per detailed specifications and obligatory requirements.

2.16 **P.S.T. Sump Cum Blending Tank, Pump Housewith recirculation pumps:**

Designing providing and constructing pump house of appropriate size with

pumps, ceiling height minimum 6m over the circular sump for discharging the sludge to thickener and recycling of flow for blending with D.I. piping etc. complete as per detailed specifications.

- 2.17 **Sludge Centrifuge Room with Centrifuges:**
Designing, providing constructing and installing including foundation etc. Sludge Centrifuge to handle the sludge flow of one day in one hour per unit with sludge dewatering unit drain etc. Complete as per specifications. Sludge centrifuge with all necessary arrangements as per detailed specifications mentioned in Volume -II and Volume -III of tender and obligatory provisions, be provided with satisfactory functioning.
- 2.18 **Gas Holder:**
Designing, providing and constructing gas holder having gas collection system, gas flow meter and gas burner with floating dome arrangement and storage time 6 hrs. to be constructed in M-300 having appropriate diameter as per detailed specifications and obligatory provisions. The floating dome shall be of 8mm thick M.S. Plate minimum and shall be provided with two coats of anticorrosive epoxy coating from both faces.
- 2.19 **Outfall Sewer:**
Designing providing and constructing appropriate Outfall Sewer of R.C.C. NP-2 pipe, to discharge treated effluent, untreated effluent form outlet chamber (after secondary clarifier) to the local nallah at a point shown on the drawing including necessary chambers for inspection / cleaning including necessary excavation dewatering, refilling, concrete encasing/bedding concrete steps to reach the nallah bed level, pitching and energy dissipation chamber in the nallah portion etc. complete.
- 2.20 **Piping work in D.I.- including Sluice Valve, Reflux Valve, M. S. Gate:**
Providing laying and jointing pipes other than those already included in the above items for interconnection by-pass drains etc. of all units including adequate numbers of manhole chambers. The item includes excavations, refilling and hydraulic testing of pipes, valves, gates accessories and cost of jointing materials. The item includes required channels with gates for interconnection of units by pass drains etc. for all units and as directed etc. complete as per detailed specifications.
- 2.21 All the structural steel work / fabrications are to be provided with application of Hot Dip Zinc coating according to specifications as per IS 4759 :1996 (Reaffirmed 2006)
- 2.22 **Administrative Building cum Laboratory (G+1)**
Designing providing and constructing Administrative Building, Office Cum Laboratory including stores. This shall be a building having appropriate Carpet area at ground floor and at first floor complete as per specifications including necessary excavation, foundation in RCC M-250 framed structure B. B.

masonry (II-Class in C. M. 1:6) 20 mm cement plaster in C. M. 1:3 inside and outside painting. Aluminum door and window with glass panels, mosaic tile flooring and skirting and all other allied items, fixtures fastening electrification arrangement water supply arrangement etc. complete. The building will have laboratory on upper floor of administrative building and should be so centralised that it should not be attached with any unit but should have complete control of every unit as per Laboratory Equipment, beautification, telephone and intercom arrangement and Wireless system etc. complete.

2.23 **This USOR contains the rates of all the items without GST. No claims against GST shall be entertained at any level. GST shall be paid by the Agency/ Contractor directly to the concerning department. Howerer, All the estimates prepared on this USOR will include GST, as an extra amount as per prevailing rates on the sum of the estimate to arrive at the gross amount.**

2.24 **Rate for Primaryand secondarytreatment-with digesters, sludge drying beds etc.complete:**

| Sr. No. | Capacity of Plant | Unit | Rate (Rs in Lakhs) | |
|---------|---|------|--------------------|---------|
| 22.2.1 | Upto 10 MLD | MLD | 70.79 | |
| 22.2.2 | Cost of 10 MLD Plant | Job | 707.90 | 707.90 |
| 22.2.3 | Add for capacity above 10 MLD upto 20 MLD | MLD | 61.94 | |
| 22.2.4 | Cost of 20 MLD Plant | Job | 1327.30 | 1327.30 |
| 22.2.5 | Add for capacity above 20 MLD | MLD | 53.09 | |

3. **Note:**
 The rates computed in the analysis of water treatment plant and sewage treatment plant donot include the cost of (i) Out sourcing for consultancy (ii) detailed survey, (iii) soil investigation, (iv) detailed hydraulic, (v) structural designing, (vi) Lab articles, glass wares and equipments, (vii) other specifically required articles to construct the plants. (viii) disposal of sludge up to nearest natural drainage system (ix) external development like external and internal electrification, (x) cost of chemicals, man powers etc during trial run of 3 months, and (xi) cost of O &M for subsequent another 9 months, (xii) If required, suitable provision for PLC-SCADA system may also be included. Since, the above said charges has to be either owned by the agency or by the department therefore, it is necessary to include cost of these charges in the preparation of estimate. The tentative provisions for above said items may be considered as under:-

| Sr. No. | Description of items | Unit | Upto 5 MLD | Above 5 and up to 10 MLD | Above 10 and up to 25 MLD |
|----------------|--|-------------|-------------------|---------------------------------|----------------------------------|
| 1 | Out sourcing for consultancy | LS | 0.30% | 0.20% | 0.10% |
| 2 | Detailed survey, | LS | 0.30% | 0.20% | 0.10% |
| 3 | Soil investigation, | LS | 0.30% | 0.20% | 0.10% |
| 4 | Detailed hydraulic design | LS | 0.60% | 0.40% | 0.20% |
| 5 | Structural designing, | LS | 0.90% | 0.60% | 0.30% |
| 6 | Lab articles, glass wares and equipments, | LS | 3.00% | 2.00% | 1.00% |
| 7 | Other specifically required articles to construct the plants. | LS | 0.30% | 0.20% | 0.10% |
| 8 | Disposal of sludge up to nearest natural drainage system | LS | 4.50% | 2.50% | 1.50% |
| 9 | External development like external and internal electrification, | LS | 1.50% | 1.00% | 0.50% |
| 10 | Cost of chemicals, man powers etc. during trial run of 3 months, | LS | 1.50% | 1.00% | 0.50% |
| 11 | Cost of O &M for subsequent another 9 months, | LS | 6.00% | 3.20% | 2.00% |
| 12 | If required, suitable provision for PLC-SCADA | LS | 4.50% | 3.00% | 1.50% |

CHAPTER- XXIII

**R.C.C. ELEVATED SERVICE
RESERVOIRS**

CHAPTER-XXIII

R.C.C. ELEVATED SERVICE RESERVOIR

1 SCOPE OF WORK

2 The Specification covers guidelines for layout for overhead water tanks and
3 Criteria for analysis for RCC staging both for steel and concrete tanks.

3 **Applicable Codes**

- IS: 11682 -1985 (Reaffirmed in 1991): Specification for Criteria for Design of RCC
- IS: 3370 (Part I, II and IV)- Code of practice for the Reinforced Concrete structure for the storage of liquids.
- IS: 456 - Code of practice for the plain and Reinforced Concrete.
- IS: 269 - Code of practice for portland cement
- IS:383 - Code of practice for aggregates
- IS: 432(Part-I) - Code of practice for Mild Steel and Medium tensile steel bars.
- IS: 1786 - Code of practice for Cold twisted steel bars
- IS: 226 - Code of practice for Structural steel sections
- Earth work shall be done as per IS 1200 (Part-1) : 1992
- Excavation shall be done as per IS 3764: 1999
- Concrete work shall be done as per IS: 456-2000

4 **Cement:-**

Cement shall be used as per IS standard given below:-

- When the strength of concrete required is upto M-20, then O.P.C. Conforming to IS 269-1989 or P.P.C. Conforming to IS : 1498-1976 may be used.
- When the strength of concrete required is more than M-20 but upto M-30, then O.P.C. Conforming to IS : 8112 - 1989 shall be used.
- Pozzolona cement is now being widely produced all over country. This may be used in structures in contact with water as per I.S. code. In specific cases requiring higher grade of strength, use of Ordinary Portland Cement (OPC) should invariably be ensured.

5 **Sand:-**

- Sand is the fine aggregate which is obtained either from natural source like river bank or from pits etc. Sand can also be produce by crushing stone are gravels. It should pass through 4.75 mm IS sieve.
- Sand should be free from clay, dust or silt. The permissible limit for the same is 5% by weight.
- Sand should be free from organic impurities as determined is in accordance with IS : 2386 (Part-II)

- For plaster sand used should Conform to IS : 1542/1960
- For masonry work sand used should Conform to is : 166/1965
- Other I.S. Codes not specifically mentioned here but pertaining to the use of Electrically Welded Steel pipes shall form part of these Specifications.

6

Capacity:-

Capacity of the tank shall be the volume of water it can store between the designed full supply level and lowest supply level (that is, the level of the lip of the outlet pipe). Due allowance shall be made for plastering the tank from inside if any when calculating the capacity of tank.

7

Height of Staging: -

- Height of staging is the difference between the lowest supply level of tank and the average ground level at the tank site.
- Staging and other reinforced concrete members including foundation shall be designed in accordance with the requirements of IS : 456-1978. Increase in permissible stresses for column staging shall be as per IS : 456-1978.
- The staging height of 12 mtr. has been considered for the computation of the rates of ESR

8

Shape and Size:-

Generally the shape and size of elevated concrete tanks for economical design depends upon the functional requirements such as : (i) Maximum depth for water, and (ii) Height of staging.

9

Water Depth:-

Water depth in tank shall be difference of level between lowest supply level and full supply level of the tank.

10

Seismic Forces:-

- When seismic loading is considered, following two cases may be considered: (i) Tank Empty and (ii) Tank full condition.
- The seismic force acting on the support for the tank and its analysis shall be in accordance with IS : 1893 – 1975

11

Allowable bearing capacity of foundation strata and type of suitable foundation depends on (i) Capacity of tank, and (ii) Other site conditions.

12

Measurement:-

All the measurement shall be recorded under the relevant item of the work.

13

Rates:-

The rate shall include the cost of materials and labour involved in all the operations except for the items measured/ enumerated separately under clause 'Measurements', which shall be paid for separately.

14 **REINFORCED CEMENT CONCRETE ELEVATED SERVICE RESERVOIRS**

- 14.1 Designing (structurally & aesthetically), and constructing RCC elevated service reservoirs of following capacity with RCC staging consisting of columns, internal and external bracings spaced vertically as per staging of the ESR. including excavation in all types of strata, foundation concrete, cement plaster with water proofing compound to the inside face of the container including refilling & disposing off the surplus stuff within a lead of 50 meters, all labour and material charges including lowering, laying, erecting, hoisting and jointing of pipe assembly of inlet, outlet, scour, overflow and bypass arrangements as per departmental design, providing and fixing accessories such as Aluminum Ladder, C.I. manhole frame and covers water level indicators, lightening conductor, G.I. pipe railing around walk way and top slab, providing RCC staircase from ground level to balcony level along with columns and from balcony level roof top level along with container wall, M.S. grill gate of 2 mtr. height with locking arrangement of approved design RCC chambers for all valves, ventilating shafts, providing and applying three coats of weather coat paints to the structure including roof slab epoxy painting to internal surface & anti termite treatment for underground parts of the structure and giving satisfactory water tightness test as per I.S. code, The job to include painting the name of the scheme and other details on the reservoir as per the directions of Engineer-in-Charge.
- 14.2 The cost may change as per site condition looking to the uplift and type of strata.
- 14.3 The design of the structure be in accordance with relevant (I.S. 3370 - 1965 or revised)
- 14.4 The design shall satisfy the stipulations as per IS 1893-1984 and I.S. 13920/1993 for seismic force and I.S. 11682/1985 for R.C.C. staging of overhead tanks.
- 14.5 For design having more than 6 columns, provision of internal bracing is obligatory. External bracing is also obligatory.
- 14.6 The entire structure shall be in stage M-25, container M-30 mix only
- 14.7 Round mild steel bars grade - 1 Conforming to I.S. 432 part-I or high yield strength deformed bars Conforming to I.S. 1786 shall be used, grade-II mild steel bars will not be allowed.
- 14.8 Irrespective of the type of foundation proposed in the design, one set of bracing

be provided at the ground level.

- 14.9 These rates includes providing RCC staircase from ground level to balcony level along with columns and from balcony level roof top level along with container wall, including railings.
- 14.10 Staging shall have to be designed with stresses of M-25 for E.S.R. However all RCC construction should be done in M-25.
- 14.11 These rates are including the cost of uplift pressure if any and entire dewatering during execution. In case of water logging area where water is struck at shallow depth extra provision of dewatering shall be made as per site conditions.
- 14.12 75% part rate shall be payable for reinforcement concrete and plastering items of containers of E.S.R. till satisfactory hydraulic testing for water tightness is given; and till that work shall be treated as incomplete.
- 14.13 **The rates indicated in the table are including the cost of pipes, specials and valves required for inlet, outlet, washout, overflow and by-pass arrangement.** The scope of work, however and includes cost of erecting, laying and jointing of pipes and valves including cost of jointing materials up to 5 m beyond outer face of outermost column.
- 14.14 For ESR C.I. (Horizontal cast spun) pipes with class A, pipes of required dia shall be provided and C.I. specials shall be used.
- 14.15 Below mentioned rates are for foundations, with individual footing with bearing capacity of 20 t/sqm. However, for raft foundations, these rates shall be increased by:-
- (i) 10 % where safe bearing capacity (SBC) is less than or up to 5 t./sqm,
 - (ii) 7.5 % where SBC is more that 5 t/sqm and up to 10 t/sqm,
 - (iii) 5 % where SBC is more than 10 t/sqm. and up to 15 t/sqm,
 - (iv) 2.5 % where SBC is more than 15 t/sqm and less than 20 t/sqm.
- This 10 % to 2.5% is applicable for estimation of amount of ESR
- 14.16 The rates shall be increased by 30% for bearing piles upto depth of 10 m & for further increased in depth by 5 m each, it shall be increased by another 10%. These rates are applicable where raft is not feasible for pile foundations sulphate resistant cement shall only be used. Single pile for the column is not permitted group of piles shall be designed with pile cap for each column of ESR.
- 14.17 **The rates are applicable for staging height of 12 m.** These rates shall be

increased or decreased for per metre variation in this staging height as below:-

(i) Less than 12 m to 10 m staging -minus 2% per metre

(ii) More than 12 m to 15 m staging - 2 % per metre

(iii) More than 15 m to 20 m staging - 3 % per metre

(iv) More than 20 m staging - 4 % per metre

14.18 Following rates are for seismic Zone – III. For Zone IV, these rates shall be increased by 5%. Concerned Executive Engineer shall confirm the seismic zone for the scheme from seismic zones plan before estimation and adopt appropriate rates as per actual seismic zones. (Seismic maps attached in this C.S.R.)

14.19 **This USOR contains the rates of all the items without GST. No claims against GST shall be entertained at any level. GST shall be paid by the Agency/ Contractor directly to the concerning department. Howerer, All the estimates prepared on this USOR will include GST, as an extra amount as per prevailing rates on the sum of the estimate to arrive at the gross amount.**

14.20 **Rate for Elevated Service Reservoirs up to 12m staging**

| S.No. | Capacity in Litres | Unit | For Seismic Zone-III Rate (in Rs.) |
|--------------|--|------------|------------------------------------|
| 23.1 | Upto 25000 lit | Litre | 26.12 |
| 23.2 | Cost of 25000 lit capacity | Job | 653054 |
| 23.3 | Add for capacity above 25000 to 50000 lit | Litre | 13.83 |
| 23.4 | Cost of 50000 lit capacity | Job | 998902 |
| 23.5 | Add for capacity above 50000 to 75000 lit | Litre | 10.38 |
| 23.6 | Cost of 75000 lit capacity | Job | 1258286 |
| 23.7 | Add for capacity above 75000 to 100000lit | Litre | 9.22 |
| 23.8 | Cost of 100000 lit capacity | Job | 1488851 |
| 23.9 | Add for capacity above 100000 to 150000lit | Litre | 8.07 |
| 23.10 | Cost of 150000 lit capacity | Job | 1892340 |
| 23.11 | Add for capacity above 150000 to 200000lit | Litre | 6.92 |
| 23.12 | Cost of 200000 lit capacity | Job | 2238188 |
| 23.13 | Add for capacity above 200000 to 250000lit | Litre | 5.76 |
| 23.14 | Cost of 250000 lit capacity | Job | 2526394 |
| 23.15 | Add for capacity above 250000 to 300000lit | Litre | 5.76 |
| 23.16 | Cost of 300000 lit capacity | Job | 2814600 |
| 23.17 | Add for capacity above 300000 to 400000lit | Litre | 5.76 |
| 23.18 | Cost of 400000 lit capacity | Job | 3391012 |
| 23.19 | Add for capacity above 400000 to 500000lit | Litre | 4.61 |
| 23.20 | Cost of 500000 lit capacity | Job | 3852141 |

| | | | |
|--------------|---|------------|-----------------|
| 23.21 | Add for capacity above 500000 to 750000lit | Litre | 4.61 |
| 23.22 | Cost of 750000 lit capacity | Job | 5004966 |
| 23.23 | Add for capacity above 750000 to 1000000 lit | Litre | 4.61 |
| 23.24 | Cost of 1000000 lit capacity | Job | 6157790 |
| 23.25 | Add for capacity above 1000000 to 1500000 lit | Litre | 4.61 |
| 23.26 | Cost of 1500000 lit capacity | Job | 8463439 |
| 23.27 | Add for capacity above 1500000 to 2000000 lit | Litre | 3.46 |
| 23.28 | Cost of 2000000 lit capacity | Job | 10192675 |

CHAPTER- XXIV

GROUND SERVICE RESERVOIRS

AND

SUMP WELLS

CHAPTER-XXIV

GROUND SERVICE RESERVOIRS AND SUMP WELLS

1 SCOPE OF WORK

2 The Specification covers guidelines for layout for Ground water tanks and
Criteria for analysis for RCC, Steel and Concrete tanks.

3 **Applicable Codes:-**

- IS: 15472 -2004: Guidelines for planning and design of low level for evacuating storage reservoirs.
- IS: 5477 (Part I, II, III and IV)- Fixing the capacities of reservoirs.
- IS: 6939-1992 Methods for determination of evaporations from reservoirs.
- IS: 7323-1994 Operations of reservoirs –Guidelines.
- IS: 456 - Code of practice for the plain and Reinforced Concrete.
- IS: 269 - Code of practice for portland cement
- IS:383 - Code of practice for aggregates
- IS: 432(Part-I) - Code of practice for Mild Steel and Medium tensile steel bars.
- IS: 1786 - Code of practice for Cold twisted steel bars
- IS: 226 - Code of practice for Structural steel sections
- Earth work shall be done as per IS 1200 (Part-1) : 1992
- Excavation shall be done as per IS 3764: 1999
- Concrete work shall be done as per IS: 456-2000

4 **Cement:-**

Cement shall be used as per IS standard given below:-

- When the strength of concrete required is upto M-20, then O.P.C. Conforming to IS 269-1989 or P.P.C. Conforming to IS: 1498-1976 may be used.
- When the strength of concrete required is more than M-20 but upto M-30, then O.P.C. Conforming to IS : 8112 - 1989 shall be used.
- Pozzolona cement is now being widely produced all over country. This may be used in structures in contact with water as per I.S. code. In specific cases requiring higher grade of strength, use of Ordinary Portland Cement (OPC) should invariably be ensured.

5 **Sand:-**

Fine aggregates shall be used as per IS standard given below:-

- Sand is the fine aggregate which is obtained either from natural source

like river bank or from pits etc. Sand can also be produce by crushing stone are gravels. It should pass through 4.75 mm IS sieve.

- Sand should be free from clay, dust or silt. The permissible limit for the same is 5% by weight. All fine aggregates shall confirm to IS: 383.
- Sand should be free from organic impurities as determined is in accordance with IS : 2386 (Part-II)
- For plaster sand used should Conform to IS : 1542-1960
- For masonry work sand used should Conform to is : 166-1965
- Other I.S. Codes not specifically mentioned here but pertaining to the use of Electrically Welded Steel pipes shall form part of these Specifications.

6 **Coarse Aggregate:**

Coarse Aggregates shall shall be used as per IS standard given below:-

- Coarse aggregate consist of clear, hard, strong, dense, nonporous and durable pieces of crushed stone. They shall not consist pieces of elongated particles salt, alkali, vegetable matter or other deleterious material.
- All coarse aggregate shall conform to IS: 383 and tests for conformity shall be carried out as per IS: 2386 Part I to VIII. The maximum value of flakiness index for coarse aggregate shall not exceed 35%.

7 **Mortar:**

- The mortar mixing shall preferably be done in mechanical mixer operated manually or by power. Hand mixing can be restored to as long as uniform density of the mix and its strength are assured subject to prior approval of Engineer-in-charge.

8 **Curing:**

- Curing shall be commenced as soon as mortar used for finishing has hardened sufficiently and not to be damaged during curing. It shall be kept wet for a period of at least 7 days

9 **Capacity:**

Service Reservoirs are structures which are built at any convenient point in the distribution between the original source and the consumer's end. The capacity of reservoirs depends upot the type of supply, the necessity of catering for peak demand periods and the provision of reserve to cover normal break down or maintenance interruptions.

10 **Shape and Size:-**

Generally the shape and size of Ground water concrete tanks for economical design depends upon the functional requirements such as: (i) Maximum depth for water, and (ii) submergence due to ground water table.

11 **Seismic Forces:-**

- When seismic loading is considered, following two cases may be considered: (i) Tank Empty and (ii) Tank full condition.
- The seismic force acting on the support for the tank and its analysis shall be in accordance with IS: 1893 – 1975

11.1 Allowable bearing capacity of foundation strata and type of suitable foundation depends on (i) Capacity of tank, and (ii) Other site conditions.

12 **Measurement:-**

All the measurement shall be recorded under the relevant item of the finished work.

13 **Location of Reservoir:-**

It is decided on following considerations:-

- Location of reservoir in central point with respect to distribution area.
- Location near the beginning of the system.
- Location the reservoir site depends on the availability of land at suitable altitudes.

14 **Rates:-**

14.1 The rates includes charges for all tools & plants, chain pulley blocks, other appliances etc. required for lifting and laying the pipes and specials in positions as per approved drawing.

14.2 The rates include provision and use of all coverings etc. to protect the works from inclement weather etc. and from damages from falling materials and other causes.

14.3 The rates include provision of handling, storing under cover as required and returning of empty cases or containers or bags to the Public Health Engineering Department Stores without any extra cost for such materials as may be supplied by the department

14.4 Following rates are for seismic Zone – III. For Zone IV, these rates shall be increased by 5%. Concerned Executive Engineer shall confirm the seismic zone for the scheme from seismic zones plan before estimation and adopt appropriate rates as per actual seismic zones. (Seismic maps attached in this USOR)

14.5 **This USOR contains the rates of all the items without GST. No claims against GST shall be entertained at any level. GST shall be paid by the Agency/ Contractor directly to the concerning department. Howerer, All the estimates prepared on this USOR will include GST, as an extra amount as per prevailing rates on the sum of the estimate to arrive at the gross amount.**

15 **Rate for Ground Service Reservoirs and Sump Wells are follows:-**

| S.No. | Capacity in Litres | Unit | For Seismic Zone-III Rate (in Rs.) |
|--------------|---|------------|------------------------------------|
| 24.1 | Upto 25000 lit | Litre | 13.84 |
| 24.2 | Cost of 25000 lit capacity | Job | 346007 |
| 24.3 | Add for capacity above 25000 to 50000 lit | Litre | 7.26 |
| 24.4 | Cost of 50000 lit capacity | Job | 527552 |
| 24.5 | Add for capacity above 50000 to 75000 lit | Litre | 6.42 |
| 24.6 | Cost of 75000 lit capacity | Job | 688149 |
| 24.7 | Add for capacity above 75000 to 100000lit | Litre | 6.14 |
| 24.8 | Cost of 100000 lit capacity | Job | 841764 |
| 24.9 | Add for capacity above 100000 to 150000lit | Litre | 5.70 |
| 24.10 | Cost of 150000 lit capacity | Job | 1127026 |
| 24.11 | Add for capacity above 150000 to 200000lit | Litre | 4.64 |
| 24.12 | Cost of 200000 lit capacity | Job | 1358845 |
| 24.13 | Add for capacity above 200000 to 250000lit | Litre | 4.02 |
| 24.14 | Cost of 250000 lit capacity | Job | 159941 |
| 24.15 | Add for capacity above 250000 to 500000lit | Litre | 3.45 |
| 24.16 | Cost of 500000 lit capacity | Job | 2422441 |
| 24.17 | Add for capacity above 500000 to 1000000 lit | Litre | 2.93 |
| 24.18 | Cost of 1000000 lit capacity | Job | 3887441 |
| 24.19 | Add for capacity above 1000000 to 1500000 lit | Litre | 2.57 |
| 24.20 | Cost of 1500000 lit capacity | Job | 5172441 |
| 24.21 | Add for capacity above 1500000 | Litre | 1.96 |

CHAPTER- XXV

WATER METER

CHAPTER – XXV

WATER METER (MECHANICAL / ELECTROMAGNETIC)

Scope:

- 1 The specification covers the design, manufacture installation & testing of water meters.
- .2 Applicable Codes
IS 779 – 1994, Specification of Water Meter
ISO 4064 – 1993, Standard with EEC/MID certification mark
- 3 A water meter is a device used to measure the volume of water usage
- 4 Multi - jet dry dial meters are used, where the water can be charged with particles. It should have following performance characteristics.
 - Rugged, light and intelligently conceived
 - Extra dry dial counter
 - Model with pulse output ex factory with pulse values 1/10/100/1000 l/Imp
 - Approx 25% less weight than WVG brass bodies
 - Comprehensive manipulation protection by standard
 - Operating temperature 30 dia C, with security up to 50dia C
- 5 Electromagnetic flow meters are designed for water and waste water application and are available in size 50mm to 3000mm. Salient features shall be as under:
 - Modular Design.
 - Flange connections to PN, DIN, ANSI, AWWA
 - Liner - Hard rubber/ Polyurethane
 - Precise calibration
 - Fully welded sensor housing complying to IP 67/ IP 68
 - Microprocessor base signal converter with self-diagnostic features, self-prompting Manor Driven configuration from front fascia.
 - High speed signal processing system
 - Communication protocol like HART
- 6 Requirement of flow sensor for Electromagnetic flow meters

| | | | |
|---|-----|-----------------|---|
| 7 | (a) | Type | Pulsed DC excitation |
| | (b) | System | Seprate with cable output |
| | (c) | Power supply | 230 V AC, 50 Hz |
| | (d) | End connections | Flanges of Carbon steel |
| | (e) | Flange Rating | PN 40 - from Size 25mm to size 80 mm |
| | | | PN 16 - from Size 100mm to size 150 mm |
| | (f) | Earthing | Grounding Rings in SS 304 (Gr Electrodes are not acceptable). |

| | | |
|-----|---------|--|
| (g) | Marking | Direction of flow with arrow, size, Sr. No. make |
|-----|---------|--|

Measurement:

Measurement of the work includes supply and fixing of water/flow meters complete in all respect as per specifications and to the satisfaction of the

8 Rates

8.1 The rate shall include the cost of materials and labour involved in all the operations.

8.2 **This USOR contains the rates of all the items without GST. No claims against GST shall be entertained at any level. GST shall be paid by the Agency/ Contractor directly to the concerning department. Howerer, All the estimates prepared on this USOR will include GST, as an extra amount as per prevailing rates on the sum of the estimate to arrive at the gross amount.**

9 Rates of Water Meter - (Mechanical / Electromagnetic)

| Sr. No. | Description of items | Unit | Rates in Rs |
|---------|---|------|-------------|
| 25.1 | Supply and Installation of Multi Jet, dry dial, inferential type, horizontal, Magnetically coupled , class B"water meters Conforming to IS- 779: 1994 and ISO 4064: 1993 standard with EEC/ MID certification mark , with IP 68 protection class copper can register with 5 mm tempered mineral glass cover, successful Life Cycle Test Certificate from FCRI and AMR compatibility with 5 years warranty complete with brass nuts and nipples:- | | |
| | 15 mm | Each | 1344 |
| | 20 mm | Each | 2206 |
| | 25 mm | Each | 4276 |
| | 40mm | Each | 7762 |
| 25.2 | Supply and Installation of Woltman Type, dry dial, inferential type, Magnetically coupled, Class B"accuracy water meters in any position with interchangeable mechanism Conforming to ISO 4064: 1993 standard with EEC certification mark, with IP68 protection class copper can register with 5 mm tempered mineral glass cover, AMR compatibility with 5 years warranty complete and successful accuracy test certificate from FCRI, Palakkad with C.I. Body "T" Type structure:- | | |

| | | | |
|------|---|------|--------|
| | | | |
| | 50mm | Each | 10788 |
| | 65mm | Each | 11450 |
| | 80mm | Each | 13950 |
| | 100 mm | Each | 17894 |
| | 125 mm | Each | 23554 |
| | 150mm | Each | 29213 |
| | 200 mm | Each | 32894 |
| | 250 mm | Each | 81776 |
| | 300 mm | Each | 171065 |
| | 400mm | Each | 256584 |
| | 500 mm | Each | 302642 |
| 25.3 | Supply and Installation of Electromagnetic Type, Internal battery-operated with 10 years battery life, MID approved and OIML Compliant, having IP68 protected sensor and converter Converter, to measure flow velocity and volume flow, having minimum straight inlet and outlet flow of 0 DN, having maximum measuring error of +/- 0.2% of measured value, having 8 digit LCD display with GSM based data logger measuring between every 2 pulses and having a 10 year battery life:- | | |
| | 25 mm | Each | 221871 |
| | 40 mm | Each | 223144 |
| | 50 mm | Each | 223992 |
| | 65mm | Each | 228150 |
| | 80mm | Each | 228658 |
| | 100 mm | Each | 241810 |
| | 125 mm | Each | 245204 |
| | 150mm | Each | 255385 |
| | 200mm | Each | 276173 |
| | 250mm | Each | 317322 |
| | 300mm | Each | 400047 |
| 25.4 | Supply of Dirt Box with S.S. Strainer as per specifications (Dia in mm) | | |
| | 50 mm | Each | 3575 |
| | 65 mm | Each | 4057 |
| | 80 mm | Each | 5187 |
| | 100 mm | Each | 6481 |
| | 125 mm | Each | 10725 |
| | 150 mm | Each | 14969 |
| | 200 mm | Each | 20525 |
| | 250 mm | Each | 33951 |
| | 300 mm | Each | 49538 |
| | 400 mm | Each | 82895 |
| 25.5 | Electromagnetic Bulk Flow Meters | | |

| | | | |
|--|---|------|---------|
| | Supply of Electromagnetic full bore meter complete as per specification including transportation to site, storage, safety, installation, testing, commissioning, making connections with existing pipe line, including excavation at site, cuts in the existing pipe system, dewatering and reinstating the same after completion of installation as per specification and drawings including all taxes. Accuracy of meter + 0.3% of measured value, Flange connection as per AWWA & IS, Liner Hard Rubber, Fully welded sensor housing complying to IP 68 standard, Electrodes SS 316, Sensor housing SS 304, Cable gland 1/2" NPT, Sensor housing fully welded SS 304 housing with protective Polyurethane paint, Flow Transmitter/ Converter: Micro-processor based, modular design display 2 line back lit LCD for indication of actual flow rate, forward, reverse, sumtotalizer, Perfection category : IP 65 Output : One current output (4-20 mA) one scalable pulse output. | | |
| | 50mm | Each | 116313 |
| | 65mm | Each | 118649 |
| | 80mm | Each | 123515 |
| | 100 mm | Each | 137239 |
| | 150mm | Each | 149990 |
| | 200 mm | Each | 191746 |
| | 250 mm | Each | 224742 |
| | 300 mm | Each | 248685 |
| | 400 mm | Each | 422230 |
| | 450 mm | Each | 483355 |
| | 500 mm | Each | 583900 |
| | 600 mm | Each | 949775 |
| | 700 mm | Each | 1245194 |
| | 900 mm | Each | 1861896 |
| | 1000 mm | Each | 2037652 |
| | 1200 mm | Each | 2654354 |
| | 1400 mm | Each | 3271055 |
| | 2000 mm | Each | 4975635 |

CHAPTER-XXVI
ANCILLARY ITEMS

CHAPTER-XXVI

ANCILLARY ITEMS

Notes:-

- 1 The works to be executed in accordance with the General specifications of the Public Health Engineering Department, relevant IS codes for pipes/specials, jointing materials and laying works.
- 2 All materials shall confirm to relevant ISS.
- 3 **Protection against lightning –**
The principal components of a lightning protective system are:-
 - (a) Air terminations
 - (b) Down conductors
 - (c) Joints and bonds
 - (d) Testing joints
 - (e) Earth terminations, and
 - (f) Earth electrodes
- 4 **Material requirement of the lightning conductor shall be as under:-**
 - Copper - Solid or flat copper strip of at least 98% conductivity conforming to relevant IS : specifications shall be used.
 - Aluminium - Aluminium 99% pure, and with sufficient mechanical strength, and protected against corrosion shall be used.
 - Aluminium should not be used underground, or in direct contact with walls.
- 5 **General requirement of Installation:-**
 - The entire lightning protective system should be mechanically strong to withstand the mechanical forces produced in the event of a lightning strike.
 - Conductors shall be securely attached to the building, other object to be protected by fasteners, which shall be substantial in construction, not subject to breakage, and shall be of galvanized steel or other suitable materials, with suitable precautions to avoid corrosion.
 - The lightning conductors shall be secured not more than 1.2m apart for horizontal run, and 1m for vertical run.
- 6 **Joints:-**
 - A lightning protective system should have as few joints as possible.
 - Joints should be mechanically and electrically effective, for example, clamped, screwed, bolted, crimped, riveted or welded.
 - With overlapping joints, the length of the overlap should not be less

than 20mm for all types of conductors.

- Contact surfaces should first be cleaned then inhibited from oxidation with a suitable non-corrosive compound.
- Joints of dissimilar metals should be protected against corrosion or erosion from the elements or the environment and should present an adequate contact area.

7

Bonds:-

- Bonds have to join a variety of metallic part of different shape and composition and cannot therefore be of a standard form.
- There is a constant problem of corrosion and careful attention must be given to the metals involved, i.e. the metal from which the bond is made, and those of the items being bonded.
- The bond must be mechanically and electrically effective, and protected from corrosion in, and erosion by the operating environment.
- Structures supporting overhead electric supply, telephone and other lines must not be bonded to a lightning protective system without the permission of the appropriate authority.

8

Measurements

Measurement shall be made according to the work actually done and pavement shall be made accordingly.

9

Rates:-

.9.1

The rate shall include the cost of the material and labour involved in all the operation described in the items. The rates include all plants, chain, pulley blocks, other appliances etc. required for execution of the works.

9.2

This USOR contains the rates of all the items without GST. No claims against GST shall be entertained at any level. GST shall be paid by the Agency/ Contractor directly to the concerning department. Howerer, All the estimates prepared on this USOR will include GST, as an extra amount as per prevailing rates on the sum of the estimate to arrive at the gross amount.

CHAPTER-XXVI
ANCILLARY ITEMS

| Item No. | Items | Unit | Rate in Rs. |
|----------|---|------|-------------|
| 26.1 | Providing and fixing in position copper lightning conductor as per IS 3070 - 1965 (with up to date amendment) including copper rod of 20mm dia as per upper terminal 1.5M long with a knob at end and with conical spike at top, copper tape conductor 20x3mm size, copper earth plate of 3mm thick and 0.81 sqm. in area, clamps at 1 M centre to centre including, necessary excavation, laying and fixing the conductor, providing and fixing 40mm G.I. pipe upto 3 M height from ground and 0.5M below ground including making all connections, filling the earthing pit with charcoal, salt, etc. and refilling and watering, etc. complete as per specifications laid down in I.S. codes 3070. | | |
| 26.1.1 | For Tape of 10M length | Each | 10177 |
| 26.1.2 | Rebate / Extra rate per metre length or part there of over and above initial length of 10M | Mtr. | 347 |
| 26.2 | Providing and fixing in position copper lightning conductor as per IS 3070 - 1965 (with up to date amendment) including copper rod of 20mm dia as per upper terminal 1.5M long with a knob at end and with conical spike at top, Aluminium tape conductor 20x3mm size, copper earth plate of 3mm thick and 0.81 sqm. in area, clamps at 1 M centre to centre including, necessary excavation, laying and fixing the conductor, providing and fixing 40mm G.I. pipe upto 3 M height from ground and 0.5M below ground including making all connections, filling the earthing pit with charcoal, salt, etc. and refilling and watering, etc. complete as per specifications laid down in I.S. codes 3070 | | |
| 26.2.1 | For tape of 10 M length | Each | 7954 |
| 26.2.2 | Rebate / Extra rate per metre length or part thereof over and above initial length of 10M | Mtr. | 125 |
| 26.3 | Providing, hoisting and fixing in position | Each | 1321 |

| Item No. | Items | Unit | Rate in Rs. |
|-----------------|---|-------------|--------------------|
| | inverted "J" type 100 mm dia. C.I. Cowl type ventilators with mosquito proof aluminium mesh at top including applying 2 coats of anti-corrosive paint, etc. complete as directed by Engineer-in-charge, weighing not less than 35 Kg | | |
| 26.4 | Providing, hoisting and fixing in position C.I. manhole, frame and cover of best quality and of required size and shape with locking arrangements including applying 2 coats and anti-corrosive paint, etc. complete. | | |
| 26.4.1 | 90 x 60 cm size and weight 35 kg | Each | 2938 |
| 26.5 | Providing and fixing in position M.S. ladder 0.50M wide consisting of 75x10mm M.S. flats as stringers and 16mm dia M.S. bars in double rows as steps placed at 25cm c/c including cost of material and labour involved, welding, anchoring and applying 3 coat of anti-corrosive paint, etc. complete as directed by Engineer-in-charge. | RM | 3277 |
| 26.6 | Providing and applying epoxy paint of approved make (Shalimar, Ciba or Mahindra & Mahindra) to concrete surface of RCC ESR & GSR or any other structure including cleaning the surface by scrapping and air blowers to the satisfaction of Engineer-in-charge, necessary scaffolding, etc. complete with all leads and lifts and giving satisfactory hydraulic test for water tightness as per I.S. codes. | | |
| 26.6.1 | For new surfaces -Two coats | Sq.m | 56 |
| 26.6.2 | For old surfaces -Two coats | Sq.m | 61 |
| 26.7 | Providing and constructing RCC spiral staircase in M-15 mix concrete at site of work and consisting of central vertical column of 400mm dia and steps in RCC M-15, tie members at each brace level, RCC parapet wall 80cm high including cost of all labour and material involved, cost of scaffolding, centering, shuttering, curing finishing in CM 1:3 proportion including RCC M-15 footing foundation, its excavation, refilling and cleaning the site, the complete as per type design, with 3 coats of cement paint. | Rmt. | 6759 |

| Item No. | Items | Unit | Rate in Rs. |
|------------------------------------|---|------|-------------|
| 26.8 | Providing and constructing RCC ventilating shaft of diameters and height mentioned below with required number of RCC 15x15cm size columns and RCC circular slab or dome over the pillars in M-15 including cost of all material and labour, providing and fixing steel or wooden frame & providing & fixing G.I. flyproof mesh of 26 gauge and providing and applying in 3 coats of oil paint to wooden or steel frame and cement paint to concrete structure. etc complete as directed by Engineer-in-charge. | | |
| 26.8.1 | 0.9 M dia x 1.35 M height | Each | 7251 |
| 26.8.2 | 1.2 M dia x 1.80 M height | Each | 9217 |
| 26.8.3 | 1.5 M dia x 2.25 M height | Each | 14747 |
| Electro Chlorination System | | | |
| 26.9 | <p>Providing, erecting, commissioning and giving test & trial for a period of one month including one year free maintenance after commissioning of Electro chlorinator capable of generating chlorine from common salt by electrolysis using electrodes in form of sodium hypo chlorite solution containing 6-8 gms/lit of available chlorine in batch or continuous process and capable of providing 8 hrs storage of hypochlorite in case of power failure. The electro chlorinator shall comprise of following:</p> <ul style="list-style-type: none"> • Electrolytic cell consisting dimensionally stable electrodes made from Gr I Titanium sheet with multi metal oxide coating. Electrolyzer tank made from PVC-FRP or Acrylic • Power pack consisting of transformer rectifier for generating suitable DC current from AC supply along with the control switch for dosing pumps etc. through MCB's contacts, relays and wiring. • Control panel for the electro chlorinator consisting of DC voltage and current display income phase status unit on-off switches fuses etc. • Dosing tank of suitable capacity made from | | |

| Item No. | Items | Unit | Rate in Rs. |
|----------|--|------|-------------|
| | PVC/FRP. <ul style="list-style-type: none"> • Dosing pumps of specials quality (1W+1S) suitable to handle hypo chlorite solution. • Entire chlorine solution pipeline shall be of PVC. • Chlorine test kit suitable to measure residual chlorine up to 5 ppm. | | |
| 26.9.1 | 25 gms/hr | Each | 280960 |
| 26.9.2 | 50 gms/hr | Each | 342797 |
| 26.9.3 | 100 gms/hr | Each | 454436 |
| 26.9.4 | 150 gms/hr | Each | 499414 |
| 26.9.5 | 250 gms/hr | Each | 702402 |
| 26.9.6 | 350 gms/hr | Each | 847066 |
| 26.9.7 | 500 gms/hr | Each | 1134004 |
| 26.9.8 | 750 gms/hr | Each | 1454121 |
| 26.9.9 | 1000 gms/hr | Each | 1828485 |
| 26.9.10 | 1500 gms/hr | Each | 2404603 |
| 26.9.11 | 2000 gms/hr | Each | 2824551 |
| 26.9.12 | 3000 gms/hr | Each | 3902063 |
| 26.10 | Providing, erecting, installing & commissioning Barometric Chlorination system for water treatment plant upto 5 MLD capacity as per manufacturers specification with all required materials viz 15 Kg. Pressure yellow P.V.C. pipe, Specially prepared chamber, mixing chamber, Scrubber unit, Gas pressure flexible pipe, brass nozzle nipple, electronic alarm unit, PPM dose, indicator of 25mm dia 4mm thick glass tube Borosil, gas unit opening spanner 3 hole type. Instruction board, aluminium pipe upto sump (maximum length 15M) etc. including civil works wherever required for above materials fittings, including satisfactory test & trial at work site etc. complete (Item do not include construction of chlorine gas room of 3.0x3.0M or adequate size.) as per drawing attached. | | |
| 26.10.1 | For WTP upto 5 MLD | Each | 119957 |
| 26.10.2 | Add / deduct per MLD or part | MLD | 5998 |
| 26.11 | Providing and fixing water level indicator upto 5 mtr ht. MS enable gauge plate 300mm wide 3 mm thick, copper float, providing and fixing | Each | 6911 |

| Item No. | Items | Unit | Rate in Rs. |
|-----------------|---|-------------|--------------------|
| | required accessories such as pointer, pulleys, nylon thread including cost of all material, labour etc. complete. | | |
| 26.12 | Providing and fixing water level indicator upto 5 mtr height including MS enable gauge plate 150mm wide 3 mm thick, copper float, providing and fixing required accessories such as pointer, pulleys, nylon thread including cost of all material, labour etc. complete | Each | 5204 |
| 26.13 | Providing pressure grouting at a pressure of 0.56 kg./sqcm in required row/zigzag fashion as specified at 1.5 M interval as per site conditions to stop leakages through water retaining structures to the entire satisfaction of the Engineer-in-charge including compound / hardening materials, compressor equipment, scaffolding, smooth finishing, etc. complete, for concrete / Masonry structure | Bag | 642 |
| 26.14 | Providing and applying epoxy paint of approved make to concrete surface of RCC ESR or GSR including cleaning the surface by scrapping and air blowers to the satisfaction of Engineer-in-charge, necessary scaffolding, etc. complete with all leads and lifts and giving satisfactory hydraulic test for water tightness as per relevent I.S. codes. | | |
| 26.14.1 | For new surfaces - Two coats. | Sqm. | 247 |
| 26.14.2 | For old surfaces - Two coats | Sqm. | 264 |
| 26.15 | Finishing with Epoxy paint (two or more coats) at all locations prepared and applied as per manufacturer's specifications including appropriate priming coat, preparation of surface, etc. complete | | |
| 26.15.1 | On steel work | Sqm. | 116 |
| 26.15.2 | On concrete work | Sqm. | 118 |
| 26.16 | Removing dry or oil bound distemper, water proofing cement paint and the like by scrapping, sand papering and preparing the surface smooth including necessary repairs to scratches etc. complete. | Sqm. | 7 |
| 26.17 | Painting with synthetic enamel paint of approved brand and manufacture of required colour to give an even shade: One or more coats on old work. | Sqm | 54 |

PART (C)

ELECTRICAL
&
MECHANICAL WORKS

CHAPTER - XXVII

TECHNICAL NOTE FOR CONSTRUCTION OF TUBEWELL AND ALLIED WORKS

CHAPTER- XXVII

TECHNCALL NOTES

CONSTRUCTION OF TUBEWELL AND ALLIED WORKS

- 27.1 The rates for various items of drilling works given in this unified schedule of rates are based on average rates for whole of the Madhya Pradesh State. The market rates may vary from place to place in the state depending upon the local conditions. No contract shall, therefore be awarded directly at the rates given in this unified schedule of rates without inviting tenders as perrules.
- 27.2 Tube wells drilled shall be perfectly vertical. The rates for drilling are inclusive of the verticality test required to be conducted. All the relevant Indian standards specifications of the B.I.S. shall also beapplicable.
- 27.3 For locating the proper site for tube well construction within the selected habitation, if resistivity survey is required then the resistivity survey shall be carried out by a well qualified and experienced geohydrologist using his own suitable resistivitymeter.
- 27.4 In the ordinary tube wells the casing pipe of specified diameter shall be lowered up to a minimum depth of 9 meters below ground level. If the collapsible strata in overburden continues beyond 9 meters depth then the casing pipe shall be lowered up to rock level and embedded in rock in adepth of 0.15 meter. The casing pipe shall also be extended above ground level in a height of about 0.3meter.
- 27.5 The diameter of ordinary tube wells constructed for installation of hand pumps shall be 125 mm up to bottom level of the casing pipe and 115 mm in the rock below the casing. Such tube wells shall be designated as 125/115 mm dia ordinary tubewells.
- 27.6 The ordinary tube wells constructed for installation of hand pumps in the basaltic rock area where intertrappean formation (collapsible strata between the rocks) is present. The nominal diameter of the tube well up to the level of intertrappean formation shall be 150 mm. The intertrappean formation shall be cased by 125 mm dia G.I. casing pipe. Therefore, the finished nominal diameter of tube well in the intertrappean formation shall be 125mm but in the rock below the intertrappean formation, the nominal diameter of tube well shall be 115 mm. Such tube wells shall be designated as 150/125/115 mm dia ordinary tubewells.

- 27.7 The nominal diameter of ordinary tube wells constructed for installation of power pumps shall be 150 mm or 200 mm for the entire depth depending upon the type and size of pump to be installed in the tube well. Such tube wells shall be designated as 150 mm dia ordinary tube well & 200 mm dia ordinary tubewells.
- 27.8 The gravel packed tube wells shall be constructed in alluvial formations, suitable for such tube wells, in which the fine and uniform sand is present in the water bearing aquifer. Such tube wells shall be constructed by direct circulation rotary drilling method or reverse circulation rotary drilling method using suitable rotary drilling machine.
- 27.9 The diameters of boreholes for construction of 100 mm, 150 mm & 200 mm finished nominal diameter gravel packed tube wells shall be 300 mm, 350 mm and 400 mm respectively exclusive of pipe wall thickness. The thickness of the gravel shroud around the screen shall generally be not less than 10 cm. Such tube wells shall be designated as 300(100) mm dia, 350(150) mm dia, 400(200) mm dia gravel packed tubewells.
- 27.10 The gravel packed tube wells shall be constructed only after obtaining the technical clearance of drawing & design of gravel packed tube well from the concerned Chief Engineer.
- 27.11 The rates are inclusive of the preparation and submission of strata chart of the tube well constructed in the prescribed proforma.
- 27.12 It shall be the responsibility of the contractor to collect the water sample from completed tube well and send it to departmental laboratory for chemical and bacteriological analysis. The water sample for chemical analysis shall be collected in 2 liters plastic bottle and samples for bacteriological analysis shall be collected in 300 ml sterilized bottle as per the direction of Engineer in charge. Only testing charges will be borne by the department.
- 27.13 All risks of accidents and Jamming and breaking of drilling tools etc. shall be contractor's liability. No extra charges shall be payable to the contractor on this account.
- 27.14 Contractor shall also make arrangements of first aid facilities for any accident. All care and precautions shall be taken and it shall be ensured that there shall be no accidents while drilling the borehole. Proper dress and equipments like gumboots, helmets etc. shall be provided by the contractor to the workmen at site.

27.15 During any operation carried out for construction of tube well, if any tool, pipe etc. falls down in the tube well then the contractor shall carry out the necessary fishing operation at his own cost. The contractor shall use his own equipment for such operation. If the tube well becomes useless due to any reason, it shall be treated as abandoned tube well and no payment shall be made for such abandoned tube well.

The contractor shall be fully responsible to fill up the abandoned bore hole with hard soil including compaction and watering so as to make top surface as good as original soil immediately and before shifting the drilling machine to prevent any accident. No payment would be made to the contractor on account of this.

27.16 If a tube well is found dry or with less yield and if it is not to be used for water supply due to any reason, the tube well shall be fitted with MS cap securely and a concrete block of 0.45m X 0.45m X 0.45m with M15 cement concrete would be constructed on it to prevent any accident or damage to the tube well and also to use the bore at any later stage for recharging or for any other purpose.

27.17 The Lowering and fixing of casing pipe in ordinary tube well and lowering of casing assembly in the gravel packed tube wells shall be done in the presence of authorised representative of the Engineer in Charge of work. The G.I. casing pipe to be lowered and fixed in intertrappean formation shall be jointed by welding only. In the case of gravel packed tube well it shall be ensured by the contractor that the slotted pipes or screened pipes shall be lowered in the tube well at the locations of water bearing aquifers as per design. The contractor shall also ensure that joints of the pipes in casing assembly are rigid and water tight and a bail plug is properly fixed in the bottom of casing assembly.

27.18 All the gravel to be used, as pack in gravel packed tube wells shall be as specified in IS 4097: 1988 (Reaffirmed -1993).

27.19 The development of tube well shall be continued during drilling operation. At the time of flushing by compressor the discharge from tube well during the development process shall also be measured by 'V' notch for yield and shall be recorded on regular intervals for which no separate payment shall be made. In case of gravel packed tube wells, development by compressor for minimum eight hours after completion of drilling of tube well shall be done and paid as per item number 4 of chapter 5. The development of ordinary tubewells (other than gravel packed tubewells) shall be done by the drilling machines during the drilling operations and no separate payment for

development of such ordinary tubewells shall be made. The development of all type of the tubewells shall be done as per IS specifications (IS:11189-1985)

- 27.20 In case of ordinary tubewells (other than gravel packed tubewells) where power pump is to be installed, the yield test of tube well shall be conducted by suitable capacity single phase or three phase submersible pumping set to be operated by generator set or by taking temporary electric connection at site. It shall be the responsibility of the contractor to arrange for suitable capacity submersible pumping set, generator set, or temporary electrical connection, suitable measuring equipments for measuring the discharge and draw down of the tube well. The rates for item of yield test given in this unified schedule of rates include all such arrangements. The maximum duration of yield test shall be eight hours.
- 27.21 The tube well shall be disinfected after completion of yield test using bleaching powder solution as per the direction of Engineer in charge, and paid as per provision in the USoR.
- 27.22 The installation of hand pump over the tube well shall be carried out as per IS specifications (IS:15500 Part 1 to 8– 2004). All the exterior parts of pump coming in contact with the water shall be thoroughly cleaned and dusted with bleaching powder. The hand pump after installation shall be tested for its proper installation by operating it continuously at least for four hour and measuring the rate of discharge from hand pump. The rates for the item of installation of hand pump and yield test by hand pump given in this unified schedule of rates shall be applicable.
- 27.23 For construction of platform and drain for the hand pump, the contractor shall use only steel plate frame shuttering designed as per the dimensional requirement of platform and drain. This shuttering shall be got approved from the Engineer-in-Charge. In case of construction of platforms in areas having black cotton soil, the top thirty centimeters of the black cotton soil shall be excavated and replaced with morrum boulder, duly rammed and watered in layers, prior to the construction of such platforms including drain, pedestal and washing platform. Rates for these works have been provided for in the USOR.
- 27.24 All contracts based on this unified schedule of rates shall be governed by the directions and other notes and conditions given in this unified schedule of rates, in addition to all the other conditions of the agreement. As the rates in this unified schedule of rates are linked to these conditions and directions, it shall not be necessary to attach the copies of these conditions to the contract

agreement.

- 27.25 In the interpretation of description of items or rates of this unified schedule of rates and specifications, the decision of the Engineer-in-Chief shall be final.
- 27.26 The issue rates of casing pipes, hand pumps and other material given in Annexure-1 of this unified schedule rates are only for the purpose of preparing realistic estimates. These rates are not given for making purchases or for entering into any contracts.
- 27.27 The rates for various items of works given in this unified schedule of rates includes for 1% overhead, 3 % sundry and 10% contractor's profit. If the work is carried out departmentally then the rates applicable for departmental works shall be at-least 9.56% $[(100 \times 11) / 115]$ less than the rates of various items given in this unified schedule of rates.
- 27.28 The following Indian standard shall be referred to:-
- 27.28.1 I.S:2800 (Part-I):1991 (Reaffirmed 2001)-Code of practice for construction & testing of tube wells/Borewells.
 - 27.28.2 I.S:2800(Part-II):1979 (Reaffirmed 1999)-Code of practice for construction & testing of tube wells/Borewells.
 - 27.28.3 I.S: 4097-1988(Reaffirmed 1999): Specification for Gravel for use as pack in tubewells
 - 27.28.4 I.S:11189-1985(Reaffirmed 1999): Methods of tube well development
 - 27.28.5 I.S:1239 (Part-I) 1990 Mild steel tubes, tubular & other wrought steel fittings-specifications.
 - 27.28.6 I.S:12818: 1992 Unplasticized PVC screen and casing pipes for bore/tube well-specification.
 - 27.28.7 I.S:15500 (Parts 1 to 8) Deep well hand pumps, components and special tools-specifications.
 - 27.28.8 The issue rates for various items like Hand pump, Casing pipes etc. has been arrived after adding 3% storage and handling charges and these rates are to be considered for preparation of estimates only and no payment of material shall be made on the basis of these issue rates.
 - 27.28.9 Rate for hand pump is taken as per CSIDC rate contract Ref. No. CSIDC/MKD/2019-20/05/52317/DWHP/AI/0464 dtd 01/10/2019, GST extra as applicable and Inspection charges @0.60% and GST extra as applicable.
 - 27.28.10 Rate for G.I. Pipe medium class is taken as per CSIDC rate

contract Ref. No. CSIDC/MKD/2019-20/02/52350/GSP&T/ATPL/0361 dtd 01/10/2019, and GST extra as applicable and Inspection charges @0.60% and GST extra as applicable.

27.28.11 Rates for UPVC casing pipe are taken as per CSIDC rate contract Ref. No. CSIDC/MKD/2019-20/04/52395/UPVS & CP/GPI/0366 dtd 01/10/2019, and GST extra as applicable and Inspection charges @0.60% and GST extra as applicable.

27.29 The rates for drilling provided in the Unified Schedule of Rates are inclusive of depreciation charges of all the machinery, tools & plants required for drilling operation, transportation of drilling machine, erection of machine at site, removal of machine from site after completion, cost of water, cost of drilling mud, fuel, labour and all other unforeseen items for drilling work and clearance of site after completion of work.

27.30 **This USOR contains the rates of all the items without GST. No claims against GST shall be entertained at any level. GST shall be paid by the Agency/ Contractor directly to the concerning department. Howerer, All the estimates prepared on this USOR will include GST, as an extra amount as per prevailing rates on the sum of the estimate to arrive at the gross amount.**

CHAPTER –XXVIII
RESISTIVITY SURVEY

CHAPTER- XVIII
RESISTIVITY SURVEY

| S.No. | Item | Unit | Rate in Rs. |
|--------------|---|----------------------|--------------------|
| 28.1 | Carrying out the resistivity survey by VES method using Schlumberger configuration for locating the proper spot with three soundings for drilling of tube well within the selected Habitation, including photography, interpretation of resistivity data and submission of report in the desired format along with resistivity readings, necessary graph and photographs. | Per successful point | 1633 |
| 28.2 | Geophysical & Hydrological Survey for lineament marking in field unconfined aquifer analysis, analyzing ground water movement, estimation of SWI yield finalizing of recharging structure, inclusive of preparation of requisite map and final report as per hydro-geological specification for recharging shaft along with all activities. | 1 Job | 6060 |

CHAPTER - XXIX

**CONSTRUCTION OF ORDINARY
TUBE WELL**

CHAPTER- XIX
CONSTRUCTION OF ORDINARY TUBE WELL

| S.No. | Item | Unit | Rate in Rs. |
|-------|--|-------|-------------|
| 29.1 | Drilling of perfectly vertical bore hole of a diameter to receive 125 mm nominal diameter casing pipe upto desired depth below ground level inclusive of the labour charges for transporting, lowering and fixing of 125 mm nominal diameter M.S /GI /UPVC casing pipe inside the bore hole including all works pertaining to drilling such as transportation, installation and removal of drilling machine etc.complete. | | |
| (a) | In all type of collapsible strata consisting of soils, clays, sand , moorum, gravel, blouders etc | Meter | 507 |
| (b) | In all types of rocks. | Meter | 591 |
| 29.2 | Drilling of perfectly vertical bore hole of 115 m.m. diameter up to desired depth below ground level in alltypes of rocks including all works pertaining to drilling such as transportation, installation and removal of drilling machine etc.complete. | Meter | 557 |
| 29.3 | Drilling of perfectly vertical bore hole of a diameter suitable to receive 150 mm nominal diameter casing pipe upto desired depth below ground level inclusive of the labour charges for transporting, lowering and fixing of 150 mm nominal diameter and fixing of 150 mm nominal diameter M.S./ G.I. / U.P.V.C. casing pipe inside the bore hole including all works pertaining to drilling such as transportation, installation and removal of drilling machine etc.complete. | | |
| (a) | In all type of collapsible strata consisting of soils, clays, sand , moorum, gravel, boulders etc. | Meter | 527 |
| (b) | In all types of rocks. | Meter | 639 |
| 29.4 | Drilling of perfectly vertical bore hole of 150 m.m. diameter up to desired depth below ground level in alltypes of rock including all works pertaining to drilling such as transportation, installation and removal of drillingmachine etc. complete. | Meter | 609 |
| 29.5 | Drilling of perfectly vertical bore hole of 165 m.m. diameter up to desired depth below ground level in alltypes of rock including all works pertaining to drilling such as transportation, installation and removal of drilling machine etc.complete. | Meter | 613 |

| S.No. | Item | Unit | Rate in Rs. |
|-------|---|-------|-------------|
| 29.6 | Drilling of perfectly vertical bore hole of a diameter suitable to receive 200 mm nominal diameter casing pipe upto desired depth below ground level inclusive of the labour charges for transporting, lowering and fixing of 200 mm nominal diameter M.S./ G.I. / U.P.V.C. casing pipe inside the bore hole including all works pertaining to drilling such as transportation, installation and removal of drilling machine etc.complete. | | |
| (a) | In all type of collapsible strata consisting of soils, clays, sand , moorum, gravel, boulders etc. | Meter | 545 |
| (b) | In all types of rocks. | Meter | 719 |
| 29.7 | Drilling of perfectly vertical bore hole of 200 m.m. diameter up to desired depth below ground level including allworkspectainingtodrillingsuchastransportation, installation and removal of drilling machine etc. complete. | | |
| (a) | In all type of collapsible strata (intertrappean formation) including charges for transportation , lowering and fixing of 150 mm nominal diameter GI casing pipe, weldedjoints only . | Meter | 621 |
| (b) | In all types of rocks. | Meter | 776 |
| 29.8 | Drilling of perfectly vertical bore hole of 150 mm diameter up to desired depth below ground level under all types of strata including all works pertaining to drilling such as transportation installation and removal of drilling machine etc. complete in intertrappean formations (collapsible strata between rocks) including charges for transportation and making all necessary arrangements' etc, including lowering and fixing of 125mm or 100mm nominal diameter (G.I. or U.P.V.C.casing pipe . | Meter | 625 |
| 29.9 | Providing and fixing of well cap on top of the tube well for protection | | |
| | M. S. Caps - | | |
| (a) | 100 mm dia. | each | 275 |
| (b) | 125 mm dia. | each | 310 |
| (c) | 150 mm dia. | each | 376 |
| (d) | 200 mm dia. | each | 407 |
| 20.10 | Construction of concrete block over dry tube wells for protection of size 0.45m x 0.45m x0.45m in M-15 cement concrete mix complete work. | each | 629 |

CHAPTER-XXX

CONSTRUCTION OF GRAVEL PACKED TUBEWELL

CHAPTER-XXX
CONSTRUCTION OF GRAVEL PACKED TUBEWELL

| S.No. | Item | Unit | Rate in Rs. |
|--------------|---|-------------|--------------------|
| 30.1 | Drilling of perfectly vertical bore hole of following diameters for construction of Gravel Packed tube well up to desired depth in alluvial formation consisting of Soils, Clays, Sand, Gravel, Moorum, Boulders etc. and retaining the bore hole by using suitable drilling mud or foam or temporary housing pipe including all works pertaining to drilling such as transportation, installation and removal of drilling machine etc. complete. | | |
| (a) | 300 m.m diameter | Meter | 850 |
| (b) | 350 m.m diameter | Meter | 893 |
| (c) | 400 m.m diameter | Meter | 932 |
| 30.2 | Labour charges for assembling, centering and lowering of properly designed casing pipe assembly inside the bore hole drilled for construction of Gravel Packed tube well including the cost of providing and fixing of centraliser, and transportation of casing assembly etc. complete . | | |
| (a) | Casing assembly composed of 100 m.m. diameter blank and slotted G.I. Casing pipes. | Meter | 45 |
| (b) | Casing assembly composed of 150 m.m. diameter blank and slotted G.I. Casing pipes. | Meter | 58 |
| (c) | Casing assembly composed of 200 m.m. diameter blank and slotted G.I. Casing pipes. | Meter | 71 |
| (d) | Casing assembly composed of 100 m.m. dia. UPVC blank and screened pipes. | Meter | 31 |
| (e) | Casing assembly composed of 150 m.m. dia. UPVC blank and screened pipes. | Meter | 42 |
| (f) | Casing assembly composed of 200 m.m. dia. UPVC blank and screened pipes. | Meter | 54 |
| 30.3 | Providing and fixing of M.S. bail plug as per I.S. 2800 (PART-I) 1991 in the bottom of casing assembly | | |
| (a) | 100 m.m diameter | each | 539 |
| (b) | 150 m.m diameter | each | 615 |
| (c) | 200 m.m diameter | each | 702 |

| S.No. | Item | Unit | Rate in Rs. |
|--------------|---|-------------|--------------------|
| 30.4 | Providing gravel packing with uniformly graded gravel as per I.S.4097 of 1967 (revised up to date) in the annular space between outer wall of casing pipe assembly and inner wall of bore hole including cost of gravel , transportation, stacking, washing and packing in layers of suitable thickness including all lead and lifts complete . | Cu.m | 4282 |
| 30.5 | Providing gravel with uniformly graded gravel as per I.S.4097 of 1967 (revised up to date) for gravel packing. | Cu.m | 3864 |
| 30.6 | Providing and fixing of well cap on top of the tube well for protection | | |
| | M. S. Caps - | | |
| (a) | 100 mm dia. | each | 275 |
| (b) | 125 mm dia. | each | 310 |
| (c) | 150 mm dia. | each | 376 |
| (d) | 200 mm dia. | each | 407 |
| 30.7 | Construction of concrete block over dry tube wells for protection of size 0.45m x 0.45m x 0.45 m in M-15 cement concrete mix complete work. | each | 629 |

CHAPTER-XXXI

INSTALLATION OF HAND PUMP AND CONSTRUCTION OF PLATFORM DRAIN AND SOKAGE PIT

CHAPTER-XXXI
INSTALLATION OF HAND PUMP AND CONSTRUCTION OF
PLATFORM DRAIN AND SOKAGE PIT

| S.No. | Item | Unit | Rate in Rs. |
|--------------|---|-------------|--------------------|
| 31.1 | Labour charges for installation of India Mark II Hand Pump with 30 meter long 32 mm dia. Riser pipe assembly and all other accessories including transportation of Hnad Pump from specified departmental stores to site. | Each | 1048 |
| 31.2 | Add to item No. 1 above for fixing the extra length of riser pipe assembly beyond 30 meters. | meter | 20 |
| 31.3 | Construction of 76 cm x 76 cm x 40 cm foundation block in 1:2:4 cement concrete for fixing the pedestal of Hand Pump including excavation, cost of material and labours etc. complete. | Each | 957 |
| 31.4 | Construction of cement concrete plateform as per design around the hand pump in 1:2:4 cement concrete including excavation, centering, shuttering, cost of all the materials and labours and curing etc. complete. | Each | 4190 |
| 31.5 | Construction of cement concrete plateform as per design around the hand pump in 1:2:4 cement concrete including excavation, centering, shuttering, cost of all the materials and labour and curing etc. complete. Including filling in 30 cm depth after removing Black cotton soil including ramming, watering etc. complete in areas of Black cotton soils. | Each | 4557 |
| 31.6 | Construction of cement concrete drain as per design in 1:2:4 cement concrete including excavation, centering, shuttering, cost of all the materials and labour and curing etc.complete. | meter | 328 |
| 31.7 | Construction of cement concrete drain as per design in 1:2:4 cement concrete including excavation, centering, shuttering, cost of all the materials and labourandcuringetc.complete.Includingfillingin 30 cm depth after removing Black cotton soil including ramming, watering etc.complete in areas of Black cotton soils. | meter | 458 |

| S.No. | Item | Unit | Rate in Rs. |
|--------------|--|-------------|--------------------|
| 31.8 | Construction of 1.20 m x 1.20 m x 0.20 m cement concrete washing platform in cement concrete 1:2:4 including excavation, centering, shuttering, cost of all the materials and labour and curing etc. complete. | Each | 1311 |
| 31.9 | Construction of 1.20 m x 1.20 m x 0.20 m cement concrete washing platform in cement concrete 1:2:4 including excavation, centering, shuttering, cost of all the materials and labour and curing etc. complete. Including filling in 30 cm depth after removing Black cotton soil including ramming, watering etc. complete in areas of Black cotton soils. | Each | 1480 |
| 31.10 | Construction of sokage pit of 70 cm dia. and 1.0 m deep including excavation, brick lining at top in 1:4 cement mortar, filling broken bricks etc. and cost of all the materials and labour and curing etc. complete. | Each | 965 |

CHAPTER- XXXII

DEVELOPMENT, YIELD TEST AND DISINFECTION OF TUBE WELL

CHAPTER- XXXII
DEVELOPMENT, YIELD TEST AND
DISINFECTION OF TUBE WELL

| S.No. | Item | Unit | Rate in Rs. |
|--------------|---|-------------|--------------------|
| 32.1 | Conducting the yield test of tubewell by operating the pumping set continuously for a desired time period and measuring the discharge and drawdown of tubewell at a suitable time interval as per the direction of Engineer in Charge including cost of energy, cost of installation of suitable measuring device and hire charges of pumping set etc.complete. | | |
| (a) | Submersible pumping set up to 1 to 3 H.P. | Per hour | 642 |
| (b) | Submersible pumping set above 3 to 7.5 H.P. | Per hour | 688 |
| (c) | Submersible pumping set above 7.5 H.P. | Per hour | 779 |
| 32.2 | Development of gravel packed tube well by Air Compressor of suitable capacity including hire charges for all the required tools and plants etc. complete, for maximum duration of eight hours. | Per hour | 958 |
| 32.3 | Measurement of yield of tube well by operating hand pump continuously for four hours manually. | Each | 700 |
| 32.4 | Disinfection of tube well using bleaching powder solution as per the direction of the Engineer in Charge including the cost of bleaching powder and labour etc. complete. | Each | 61 |

CHAPTER- XXXIII

ODEX TYPE OF TUBEWELL

CHAPTER- XXXIII
ODEX TYPE OF TUBEWELL

| S.No. | Item | Unit | Rate in Rs. |
|-------|--|-------|-------------------|
| 33.1 | Drilling of perfectly vertical bore hole by odex method of a diameter to receive 125 mm nominal diameter casing pipe up to desired depth below ground level inclusive of the labour charges for transporting, lowering and fixing of 125 mm nominal diameter suitable for odex drilling M.S./G.I./ Seamless casing pipe inside the bore hole BY welding joint including all works pertaining to drilling such as transportation , installationand removal of drilling machine etc. complete. | | |
| (a) | In all type of collapsible strata consisting of soils, clays, sand , moorum, gravel, boulders etc. | Meter | 755 |
| (b) | In all types of rocks. | Meter | 879 |
| 33.2 | After completion of bore hole by odex method making of slots cutting on casing pipe at the aquifers level . The size of slots is 2mm wide x 7.5mm long in set of 4 slots around the length wise in casing pipe (G.I./MS/Seamless) . Each meter length of casing should have 140 slots on total cylindrical portion of casing pipe . | Meter | 463 |
| 33.3 | Cost of casing shoe (Guide Bush) for odex drilling | Each | 5145 |
| 33.4 | Drilling of perfectly vertical bore hole by odex method of a diameter to receive 150 mm nominal diameter casing pipe upto desired depth below ground level inclusive of the labour charges fortransporting, lowering and fixing of 125 mm nominal diameter suitable for odex drilling M.S./G.I./ Seamless casing pipe indise the bore hole BY welding joint including all works pertaining to drilling such as transportation, installationandremoval of drilling machine etc. complete. | | |
| (a) | In all type of collapsible strata consisting of soils, clays, sand , moorum, gravel, blouders etc. | Meter | 817 |
| (b) | In all types of rocks. | Meter | 991 |

| S.No. | Item | Unit | Rate in Rs. |
|--------------|--|-------------|----------------------------|
| 33.5 | After completion of bore hole by odex method making of slots cutting on casing pipe at the aquifers level . The size of slots is 2mm wide x 7.5mm long in set of 4 slots around the length wise in casing pipe (G.I./MS/Seamless). Each meter length of casing should have 172 slots on total cylindrical portion of casing pipe . | Meter | 534 |
| 33.6 | Cost of casing shoe (Guide Bush) for odex drilling | Each | 5948 |

CHAPTER- XXXIV

**MISCELLANEOUS ITEMS
OF
TUBEWELL**

CHAPTER- XXXIV
MISCELLANEOUS ITEMS OF TUBEWELL

| S.No. | Item | Unit | Rate in Rs. |
|---|---|-----------|-------------|
| HYDROFRACTURING AND CLEANING OF TUBEWELL | | | |
| 34.1 | Hydro fracturing of perfectly vertical bore hole for 200/150/115 mm diameter bore hole up to 90 m depth below ground level including yield testing before and after Hydro fracture, transportation, installation and removing of Hydro fracturing unit. | 1 Job | 13689 |
| 34.2 | Cleaning of perfectly vertical bore hole for 200/150/115 mm diameter bore hole up to 60 mtrs depth below ground level including transportation, installation and removing of Drilling machine. | 1 Job | 12853 |
| 34.3 | Add to item no. 24.2 above cleaning beyond 60 m depth. | Per meter | 134 |
| 34.4 | Survey work dry/ low yield tube well hydro fracturing of tube well for detection of fracture zones in tube well by using the hole camera with monitor including transportation and providing C.D. & photographs. | Each | 1508 |
| 34.5 | Labour charges for taking out assembly from the tube well of India Mark II hand pump with 30 meters long 32mm dia riser pipe assembly and all other accessories. | Each | 885 |
| 34.6 | Add to item No. 24.5 above for fixing extra length of pipe beyond 30 meters. | Per Mtr. | 29 |
| 34.7 | Labour charges for lowering the assembly with complete fittings of India Mark II Hand pump from the tube well with 32mm dia 30 Meters long riser pipe assembly and other accessories | Each | 740 |
| 34.8 | Add to above item No. 24.7 for fixing extra length of riser pipe assembly beyond 30 meters. | Per Mtr | 24 |
| CONSTRUCTION OF RECHARGING PIT IN SUBMERGENCE AREA | | | |
| 34.9 | Construction of recharging pit of internal size 2.00 X 2.00X1.35 mtr. near Existing tube well , in submergence area of pond/ reservoir including excavation, base concrete, brick masonry work and providing and filling filter media like boulders, gravels, sand and synthetic membrane below sand as per specifications, and drawing no.19 complete. | 1 Job | 41814 |

| S.No. | Item | Unit | Rate in Rs. |
|-------|--|-------|-------------|
| | CONSTRUCTION OF RECHARGING PIT AROUND EXISTING TUBE WELL GIVING LESS YIELD WITH STEINING AND CATCH DRAIN | | |
| 34.10 | Construction of recharging circular pit of 3.00 m outer dia and 2.00 mtrs depth around the existing tube well giving less yield perforation work in casing pipe and providing and fixing of nariyal rope around perforated area in full length, steening work and surrounding catch drain work with M-20 RCC , making 90 mm dia circular holes by fixing pieces of 90 mm dia PVC pipes @ 300 mm c/c before concreting of steining work of recharge pit just below G.L. to permit rain water to enter in to the pit from catch drain, providing and filling of recharge pit by filter media like boulders, gravels sand and synthetic membrane below sand as per specifications and drawing no.20 complete. | 1 Job | 55188 |
| | CONSTRUCTION OF RECHARGING PIT AROUND TUBE WELL GIVING LESS YIELD | | |
| 34.11 | Construction of recharging circular pit of 3.00 m dia and 2.00m depth around the dry tube well, perforation work in casing pipe and providing and fixing of nariyal rope around perforated area in full length, providing and filling of recharge pit by boulders, gravels sand as filter media, synthetic membrane below sand and making ground slope towards the constructed pit to divert the rain water (in soft/hard rock area) as per specifications and drawing no. 21 complete. | 1 Job | 16795 |
| | REPAIRING OF HAND PUMP | | |
| 34.12 | Labour only for minor repairing work of India Mark II hand pump including replacement of unserviceable parts ie chain, handle, axle either one or more parts as the case may be along with overhauling of hand pump set and transportation etc as per approved specifications inclusive of the free services of departmental technician (Material will be supplied by the department). | 1 Job | 465 |
| 34.13 | Labour only for major repairing work of India Mark II hand pump including replacement of unserviceable parts such as washer, cylinder, riser pipe, link rod either one or more parts as the case may be along with overhauling, minor repairing work and transportation | 1 Job | 1076 |

| S.No. | Item | Unit | Rate in Rs. |
|--------------|--|-------------|--------------------|
| | etc as per approved specification inclusive of free services of departmental technician (Material will be supplied by the department). | | |
| 34.14 | Labour only for minor repairing work of India Mark II hand pump including replacement of unserviceable parts i.e chain, handle, axle either one or more parts as the case may be along with overhauling of hand pump set and transportation etc as per approved specifications (Material will be supplied by the department). | 1 Job | 595 |
| 34.15 | Labour only for major repairing work of India Mark II hand pump including replacement of unserviceable parts such as washer, cylinder, riser pipe, link rod either one or more parts as the case may be along with overhauling, minor repairing work and transportation etc as per approved specification (Material will be supplied by the department). | 1 Job | 1128 |
| | TAKING OUT FALLEN HAND PUMP PIPE LINE ASSEMBLY FROM TUBE WELL | | 0 |
| 34.16 | Labour only for taking out of fallen hand pump pipe line assembly from tube well using special T&P required for the same i/c depositing all the obtained material in departmental store complete item .-Depth up to 150 mtr. | 1 Job | 2514 |
| 34.16.1 | Removal of ordinarily Fallen Pipe Line of Hand Pump from Tube well i/c arrangement of labour, skilled person & arrangement of all tools and plant required for the job i/c all safety measures and transportation of recovered material from village to the departmental store or transportation of material required for hand pump installation from store to village, installation of Handpump i/c loading, unloading etc. complete. | 1 Job | 6229 |
| 34.16.2 | Removal of choked fallen pipe line of Hand Pump from TW i/c arrangement of additional labour skilled person, arrangement of all special type tools and plant required for the job, i/c all safety measures etc. all complete. (This item will be paid in addition to item No.24.16.1 if fallen pipe line is choked) | 1 Job | 2263 |
| | REMOVING OF UNSERVICEABLE | | |

| S.No. | Item | Unit | Rate in Rs. |
|---------|--|-------|-------------|
| | HANDPUMP | | |
| 34.17 | Removing of unserviceable hand pump along with assembly from existing tube well i/c excavation, cutting of casing pipe if necessary, dismantling CC around pedestal, capping of tube well i/c making of cement concrete block M-15 size 0.45x0.45x0.45 cm and depositing all the obtained material in departmental store . | 1 Job | 2084 |
| 34.18 | LOWERING & TAKING OUT OF SUBMERSIBLE PUMP SET | | |
| 34.18.1 | Labour only for taking out of single phase submersible pumping set of capacity 1 to 3 HP from the tube well with flexible/ rigid pipe line assembly, electrical cable, nylon rope, testing etc. complete including disconnecting the electrical cable from pump & starter -Depth up to 150 mtr.. | 1 Job | 1575 |
| 34.18.2 | Labour only for lowering of single phase submersible pumping set of capacity 1 to 3 HP in the tube well with flexible/ rigid pipe line assembly, electrical cable, nylon rope, testing etc. complete including connecting the electrical cable from pump & starter - Depth up to 150mtr. | 1 Job | 1730 |
| 34.18.3 | Labour only for taking out of three phase submersible pumping set from the tube well with pipe line assembly, electrical cable, testing etc. complete including disconnecting the electrical cable from pump & starter. | | |
| (i) | 3 HP to 7.5 HP - Depth up to 150 mtr. | 1 Job | 2038 |
| (ii) | Above 7.5 HP to 12.5 HP - Depth up to 150 mtr. | 1 Job | 2347 |
| (iii) | Above 12.5 HP - Depth up to 150 mtr. | 1 Job | 2655 |
| 24.18.4 | Labour only for lowering of three phase submersible pumping set in the tube well with pipe line assembly, electrical cable, testing etc. complete including connecting the electrical cable from pump & starter. | | 0 |
| (i) | 3 HP to 7.5 HP - Depth up to 150 mtr. | 1 Job | 2192 |
| (ii) | Above 7.5 HP to 12.5 HP - Depth up to 150 mtr. | 1 Job | 2501 |
| (iii) | Above 12.5 HP - Depth up to 150 mtr. | 1 Job | 2809 |
| | TAKING OUT FALLEN SUBMERSIBLE PUMPING SET FROM TUBEWELL | | |
| 34.19 | Labour only for taking out of fallen submersible pumping set from the tube well with pipe line assembly, electrical cable etc. complete using special | | |

| S.No. | Item | Unit | Rate in Rs. |
|---------|---|-------|-------------|
| | T&P required for the same i/c depositing all the obtained material in departmental store. | | |
| (i) | 1 to 3 HP - Depth up to 150 mtr. | 1 Job | 2804 |
| (ii) | 3 to 7.5 HP - Depth up to 150 mtr. | 1 Job | 2982 |
| (iii) | 7.5 to 12.5 HP - Depth up to 150 mtr. | 1 Job | 3439 |
| (iv) | Above 12.5 HP - Depth up to 150 mtr. | 1 Job | 3691 |
| | | | |
| 34.20 | REPAIRING OF SUBMERSIBLE MOTOR PUMP SET | | |
| 34.20.1 | Removing the old burn winding from stator & cleaning of slot then complete rewinding of submersible motor by using PVC insulated ISI marked quality copper conductor with suitable gauge including insulating material like bamboo, strip, fire proof papers, leave, cotton tape, PVC tape including cable jointing of motor. | | |
| A | Single phase 100 mm dia | | |
| | 1 HP | 1 Job | 2008 |
| | 2 HP | 1 Job | 2517 |
| | 3 HP | 1 Job | 2705 |
| B | Three Phase 100mm & 150 mm Dia. | | |
| | 3 HP (100mm dia.) | 1 Job | 2987 |
| | 4 HP (100mm dia.) | 1 Job | 3081 |
| | 5 HP (100mm dia.) | 1 Job | 3458 |
| | 3 HP (150mm dia.) | 1 Job | 3054 |
| | 4 HP (150mm dia.) | 1 Job | 3149 |
| | 5 HP (150mm dia.) | 1 Job | 3592 |
| | 6 HP (150mm dia.) | 1 Job | 3929 |
| | Above 6.0 to 7.5 HP (150mm dia.) | 1 Job | 5622 |
| | Above 7.5 to 10 HP (150mm dia.) | 1 Job | 6269 |
| | Above 10.0 to 12.5 HP (150mm dia.) | 1 Job | 7210 |
| | Above 12.5 to 15 HP (150mm dia.) | 1 Job | 7680 |
| 34.20.2 | Providing & Fixing of non return valve body | | |
| | 1 HP to 5 HP / 100mm | 1 Job | 434 |
| | 3 HP to 15 HP / 150mm | 1 Job | 626 |
| 34.20.3 | Providing & Fixing of Discharge outlet | | |
| | 1 HP to 5 HP / 100mm | 1 Job | 244 |
| | 3 HP to 15 HP / 150mm | 1 Job | 336 |
| 34.20.4 | Providing & Fixing of Adjusting Cap | | |
| | 1 HP to 5 HP / 100mm | 1 Job | 67 |
| | 3 HP to 15 HP / 150mm | 1 Job | 72 |
| 34.20.5 | Providing & Fixing of L N key BMM | | |
| | 1 HP to 5 HP / 100mm | 1 Job | 24 |
| | 3 HP to 15 HP / 150mm | 1 Job | 29 |

| S.No. | Item | Unit | Rate in Rs. |
|--------------|---|-------------|--------------------|
| 34.20.6 | Providing & Fixing of Bush for D O L | | |
| | 1 HP to 5 HP /100mm | 1 Job | 151.00 |
| | 3 HP to 15 HP / 150mm | 1 Job | 175.00 |
| 34.20.7 | Providing & Fixing of Sleeve for D O L | | |
| | 1 HP to 5 HP /100mm | 1 Job | 132.00 |
| | 3 HP to 15 HP / 150mm | 1 Job | 146.00 |
| 34.20.8 | Providing & Fixing of stage case CI | 1 Job | |
| | 3 HP to 15 HP / 150mm | | 333.00 |
| 34.20.9 | Providing & Fixing of Bowl bushGM | | |
| | 3 HP to 15 HP / 150mm | 1 Job | 184.00 |
| 34.20.10 | Providing & Fixing of Bowl bush Rubber | | |
| | 3 HP to 15 HP / 150mm | 1 Job | 108.00 |
| 34.20.11 | Providing & Fixing of Neck Ring GM | | |
| | 3 HP to 15 HP / 150mm | 1 Job | 156.00 |
| 34.20.12 | Providing & Fixing of Pump sleeveSS | | |
| | 3 HP to 15 HP / 150mm | 1 Job | 118.00 |
| | 1 HP to 5 HP /100mm | 1 Job | 382.00 |
| | 3 HP to 15 HP / 150mm | 1 Job | 472.00 |
| 34.20.14 | Providing & Fixing of moter bush Rubber | | |
| | 1 HP to 5 HP /100mm | 1 Job | 264.00 |
| | 3 HP to 15 HP / 150mm | 1 Job | 312.00 |
| 34.20.15 | Providing & Fixing of Impeller | | |
| | 1 HP to 5 HP /100mmPP | 1 Job | 62.00 |
| | 3 HP to 15 HP / 150mmGM | 1 Job | 406.00 |
| 34.20.16 | Providing & Fixing of Diffuser GM | | |
| | 3 HP to 15 HP / 150mm | 1 Job | 257.00 |
| 34.20.17 | Providing & Fixing of Diffuser PP | | |
| | 1 HP to 5 HP /100mm | 1 Job | 62.00 |
| | 3 HP to 15 HP / 150mm | 1 Job | 137.00 |
| 34.20.18 | Providing & Fixing of sand guard | | |
| | 1 HP to 5 HP /100mm | 1 Job | 62.00 |
| | 3 HP to 15 HP / 150mm | 1 Job | 137.00 |
| 34.20.19 | Providing & Fixing of Distance piece | | |
| | 1 HP to 5 HP /100mm | 1 Job | 45.00 |
| | 3 HP to 15 HP / 150mm | 1 Job | 108.00 |
| 34.20.20 | Providing & Fixing of Oil seal | | |
| | 1 HP to 5 HP /100mm | 1 Job | 48.00 |
| | 3 HP to 15 HP / 150mm | 1 Job | 52.00 |
| 34.20.21 | Providing & Fixing of Oil seal Sleeve | | |
| | 1 HP to 5 HP /100mm | 1 Job | 108.00 |
| | 3 HP to 15 HP / 150mm | 1 Job | 161.00 |
| 34.20.22 | Providing & Fixing of Nylon Nut | | |
| | 1 HP to 5 HP /100mm | 1 Job | 10.00 |

| S.No. | Item | Unit | Rate in Rs. |
|----------|--|-------|-------------|
| | 3 HP to 15 HP / 150mm | 1 Job | 11.00 |
| 34.20.23 | Providing & Fixing of Stud for Suction | | |
| | 1 HP to 5 HP /100mm | 1 Job | 20.00 |
| | 3 HP to 15 HP / 150mm | 1 Job | 26.00 |
| 34.20.24 | Providing & Fixing of GM Washer | | |
| | 1 HP to 5 HP /100mm | 1 Job | 7.00 |
| | 3 HP to 15 HP / 150mm | 1 Job | 12.00 |
| 34.20.25 | Providing & Fixing of Grub Screw | | |
| | 1 HP to 5 HP /100mm | 1 Job | 11.00 |
| | 3 HP to 15 HP / 150mm | 1 Job | 11.00 |
| 34.20.26 | Providing & Fixing of Pump Shaft (SS) per Stage | | |
| | 3 HP to 15 HP / 150mm | 1 Job | 180.00 |
| 34.20.27 | Providing & Fixing of Pump Shaft Key | | |
| | 1 HP to 5 HP /100mm | 1 Job | 52.00 |
| | 3 HP to 15 HP / 150mm | 1 Job | 62.00 |
| 34.20.28 | Providing & Fixing of Suction Housing | | |
| | 1 HP to 5 HP /100mm | 1 Job | 236.00 |
| | 3 HP to 15 HP / 150mm | 1 Job | 339.00 |
| 34.20.29 | Providing & Fixing of Pump Coupling & Motor Coupling | | |
| | 1 HP to 5 HP /100mm | 1 Job | 358.00 |
| | 3 HP to 15 HP / 150mm | 1 Job | 528.00 |
| 34.20.30 | Providing & Fixing of Suction Housing Plate | | |
| | 3 HP to 15 HP / 150mm | 1 Job | 239.00 |
| 34.20.31 | Providing & Fixing of Intermediate suction Case | | |
| | 3 HP to 15 HP / 150mm | 1 Job | 170.00 |
| 34.20.32 | Providing & Fixing of Suction Housing Bush | | |
| | 3 HP to 15 HP / 150mm | 1 Job | 221.00 |
| 34.20.33 | Providing & Fixing of Intermediate suction Bush | | |
| | 3 HP to 15 HP / 150mm | 1 Job | 221.00 |
| 34.20.34 | Providing & Fixing of stud for Motor flange upper | | |
| | 1 HP to 5 HP /100mm | 1 Job | 17.00 |
| | 3 HP to 15 HP / 150mm | 1 Job | 21.00 |
| 34.20.35 | Providing & Fixing of stud for Motor flange lower | | |
| | 1 HP to 5 HP /100mm | 1 Job | 26.00 |
| | 3 HP to 15 HP / 150mm | 1 Job | 33.00 |
| 34.20.36 | Providing & Fixing of Bearing Housing upper | | |
| | 1 HP to 5 HP /100mm | 1 Job | 330.00 |
| | 3 HP to 15 HP / 150mm | 1 Job | 509.00 |
| 34.20.37 | Providing & Fixing of Bearing Housing lower | | |
| | 1 HP to 5 HP /100mm | 1 Job | 330.00 |
| | 3 HP to 15 HP / 150mm | 1 Job | 509.00 |
| 34.20.38 | Providing & Fixing of upper flange & lower flange | | |
| | 1 HP to 5 HP /100mm | 1 Job | 180.00 |

| S.No. | Item | Unit | Rate in Rs. |
|----------|---|-------|-------------|
| | 3 HP to 15 HP / 150mm | 1 Job | 225 |
| 34.20.39 | Providing & Fixing of Motor base | | |
| | 1 HP to 5 HP /100mm | 1 Job | 413 |
| | 3 HP to 15 HP / 150mm | 1 Job | 537 |
| 34.20.40 | Providing & Fixing of Thrust bearing plate complete | | |
| | 1 HP to 5 HP /100mm | 1 Job | 704 |
| | 3 HP to 15 HP / 150mm | 1 Job | 799 |
| 34.20.41 | Providing & Fixing of Thrust bearing (Carben) | | |
| | 1 HP to 5 HP /100mm | 1 Job | 480 |
| | 3 HP to 15 HP / 150mm | 1 Job | 595 |
| 34.20.42 | Providing & Fixing of Revolving disk | | |
| | 1 HP to 5 HP /100mm | 1 Job | 345 |
| | 3 HP to 15 HP / 150mm | 1 Job | 528 |
| 34.20.43 | Providing & Fixing of Thrust bearing housing CI | | |
| | 1 HP to 5 HP /100mm | 1 Job | 134 |
| | 3 HP to 15 HP / 150mm | 1 Job | 206 |
| 34.20.44 | Providing & Fixing of Rotor Sleeve | | |
| | 1 HP to 5 HP /100mm | 1 Job | 173 |
| | 3 HP to 15 HP / 150mm | 1 Job | 210 |
| 34.20.45 | Providing & Fixing of Rubber Parts | 1 Job | |
| | 1 HP to 5 HP /100mm | 1 Job | 58 |
| | 3 HP to 15 HP / 150mm | | 76 |
| 34.20.46 | Providing & Fixing of Intermediate coupling | | |
| | 1 HP to 5 HP /100mm | 1 Job | 288 |
| | 3 HP to 15 HP / 150mm | 1 Job | 317 |
| 34.20.47 | Providing & Fixing of Flange locking | | |
| | 1 HP to 5 HP /100mm | 1 Job | 49 |
| | 3 HP to 15 HP / 150mm | 1 Job | 53 |
| 34.20.48 | Providing & Fixing of Disk Locking | | |
| | 1 HP to 5 HP /100mm | 1 Job | 19 |
| | 3 HP to 15 HP / 150mm | 1 Job | 21 |
| 34.20.49 | Providing & Fixing of Chuck Nut | | |
| | 1 HP to 5 HP /100mm | 1 Job | 37 |
| | 3 HP to 15 HP / 150mm | 1 Job | 49 |
| 34.20.50 | Providing & Fixing of 8 mm Nut SS | | |
| | 3 HP to 15 HP / 150mm | 1 Job | 11 |
| 34.20.51 | Providing & Fixing of 10 mm Nut SS | | |
| | 1 HP to 15 HP / 150mm | 1 Job | 15 |
| 34.20.52 | Providing & Fixing of 12 mm Nut SS | | |
| | 1 HP to 15 HP / 150mm | 1 Job | 19 |
| 34.20.53 | Providing & Fixing of Stud for Suction | | |
| | 1 HP to 15 HP / 150mm | 1 Job | 24 |
| 34.20.54 | Providing & Fixing of Top Bush & Top Sleeve | | |
| | 1 HP to 5 HP /100mm | 1 Job | 268 |

| S.No. | Item | Unit | Rate in Rs. |
|----------|---|-------|-------------|
| | 3 HP to 15 HP / 150mm | 1 Job | 33 |
| 34.20.55 | Providing & Fixing of Pump intermediate bush & sleeve | | |
| | 1 HP to 5 HP /100mm | 1 Job | 259 |
| | 3 HP to 15 HP / 150mm | 1 Job | 317 |
| 34.20.56 | Providing & Fixing of Pump stainer | | |
| | 1 HP to 5 HP /100mm | 1 Job | 103 |
| | 3 HP to 15 HP / 150mm | 1 Job | 141 |
| 34.20.57 | Providing & Fixing of center D O | | |
| | 1 HP to 5 HP /100mm | 1 Job | 164 |
| | 3 HP to 15 HP / 150mm | 1 Job | 336 |
| 34.20.58 | Providing & Fixing of New rotor | | |
| | 1 HP (100 mm dia) | 1 Job | 4986 |
| | 2 HP (100 mm dia) | 1 Job | 5370 |
| | 3 HP (100 mm dia) | 1 Job | 6041 |
| | 4 HP (100 mm dia) | 1 Job | 6616 |
| | 5 HP (100 mm dia) | 1 Job | 7192 |
| | 3 HP (150 mm dia) | 1 Job | 8054 |
| | 4 HP (150 mm dia) | 1 Job | 8151 |
| | 5 HP (150 mm dia) | 1 Job | 8342 |
| | 6 HP (150 mm dia) | 1 Job | 8917 |
| | Above 6.0 to7.5 HP (150 mm) | 1 Job | 10164 |
| | Above 7.5 to 10 HP (150 mm) | 1 Job | 11218 |
| | Above 10.0 to 12.5 HP (150 mm) | 1 Job | 15341 |
| | Above 12.5 to 15 HP (150 mm) | 1 Job | 17259 |
| 34.20.59 | Providing & Fixing of Adapter Piece | | |
| | 1 HP to 5 HP /100mm | 1 Job | 173 |
| | 3 HP to 15 HP / 150mm | 1 Job | 240 |
| 34.20.60 | Providing & Fixing of Water drain plug | | |
| | 1 HP to 5 HP /100mm | 1 Job | 39 |
| | 3 HP to 15 HP / 150mm | 1 Job | 49 |
| 34.20.61 | Providing & Fixing of Cable Guard | | |
| | 1 HP to 5 HP /100mm | 1 Job | 113 |
| | 3 HP to 15 HP / 150mm | 1 Job | 141 |
| 34.20.62 | Labour only for stator servicing :- | | |
| | 1 HP - 5 HP / 100 mm | 1 Job | 480 |
| | 3 HP - 5 HP / 150mm | 1 Job | 498 |
| | 5 HP - 10 HP / 150mm | 1 Job | 623 |
| | 10 HP - 15 HP / 150mm | 1 Job | 720 |
| 34.20.63 | Labour only for Rotor Balancing :- | | |
| | 1 HP - 5 HP / 100 mm | 1 Job | 767 |
| | 3 HP - 5 HP / 150mm | 1 Job | 863 |
| | 5 HP - 10 HP / 150mm | 1 Job | 1054 |
| | 10 HP - 15 HP / 150mm | 1 Job | 1342 |

| S.No. | Item | Unit | Rate in Rs. |
|--------------|---|-------------|--------------------|
| 34.20.64 | Labour only for Impeller Brass welding & Turning | 1 Job | 288 |
| 34.20.65 | Labour only for Motor Rotor sleeve turning & grinding | 1 Job | 623 |
| 34.20.66 | Labour only for Flange stud Welding | 1 Job | 39 |
| 34.20.67 | Labour only for Motor opening, servicing, fitting & testing | 1 Job | 432 |
| 34.20.68 | Labour only for Copper welding, Turning & Grinding to enduring of rotor | 1 Job | 767 |
| 34.20.69 | Labour only for Welding Turning key way cutting of coupling side of rotor | 1 Job | 383 |
| 34.20.70 | Labour only for Pump opening & fitting | 1 Job | 383 |
| | REPAIRING OF CONTROL PANEL | | |
| 34.20.71 | Providing & Fixing of Relay unit L&T Type | 1 Job | 570 |
| 34.20.72 | Providing & Fixing of Relay unit BCH Type | 1 Job | 1290 |
| 34.20.73 | Providing & Fixing of Contactor L&T Type - 16 Amp | 1 Job | 1098 |
| 34.20.74 | Providing & Fixing of Contactor BCH Type - 16 Amp | 1 Job | 1577 |
| 34.20.75 | Providing & Fixing of Contactor BCH Type - 25 Amp | 1 Job | 2057 |
| 34.20.76 | Providing & Fixing of Kit Point Set L&T Type | 1 Job | 427 |
| 34.20.77 | Providing & Fixing of Kit Point Set BCH Type -16 Amp | 1 Job | 810 |
| 34.20.78 | Providing & Fixing of Kit Point Set BCH Type - 25 Amp | 1 Job | 618 |
| 34.20.79 | Providing & Fixing of No Volt Coil L&T Type | 1 Job | 427 |
| 34.20.80 | Providing & Fixing of No Volt Coil BCH Type | 1 Job | 427 |
| 34.20.81 | Providing & Fixing of Timer Set L&T Type | 1 Job | 1290 |
| 34.20.82 | Providing & Fixing of Timer Set BCH Type | 1 Job | 1577 |
| 34.20.83 | Providing & Fixing of Auxillary Switch | 1 Job | 532 |
| 34.20.84 | Providing & Fixing of Timer Coil | 1 Job | 398 |
| 34.20.85 | Providing & Fixing of Amp meter (Round) | 1 Job | 125 |
| 34.20.86 | Providing & Fixing of Volt Meter (Round) | 1 Job | 125 |
| 34.20.87 | Providing & Fixing of Amp meter (Square) | 1 Job | 173 |
| 34.20.88 | Providing & Fixing of Volt Meter (Square) | 1 Job | 173 |
| 34.20.89 | Providing & Fixing of ON Switch | 1 Job | 86 |
| 34.20.90 | Providing & Fixing of Off Switch | 1 Job | 86 |
| 34.20.91 | Providing & Fixing of Terminal Plate | 1 Job | 139 |
| 34.20.92 | Providing & Fixing of Indicator Lamp | 1 Job | 34 |
| 34.20.93 | Providing & Fixing of MCB -Single Pole - 16 -25 Amp | 1 Job | 110 |

| S.No. | Item | Unit | Rate in Rs. |
|-----------|--|-----------|-------------|
| 34.20.94 | Providing & Fixing of MCB -Three Pole - 32 Amp | 1 Job | 658 |
| 34.20.95 | Providing & Fixing of MCB -Three Pole - 40 Amp | 1 Job | 618 |
| 34.20.96 | Providing & Fixing of MCB -Three Pole - 63 Amp | 1 Job | 666 |
| 34.20.97 | Providing & Fixing of Capacitor 36 MFD | 1 Job | 331 |
| 34.20.98 | Providing & Fixing of Capacitor 50 MFD | 1 Job | 331 |
| 34.20.99 | Providing & Fixing of Capacitor 120-150 MFD | 1 Job | 350 |
| 34.20.100 | Providing & Fixing of Capacitor 200-250 MFD | 1 Job | 369 |
| 34.20.101 | Providing and fixing of suitable rating ISI marked wired with lugs & sleeves in place of burnt wiring of control panel. | | |
| | 1 HP - 3 HP (Single Phase) | 1 Job | 413 |
| | 3 HP - 5 HP (Three Phase) | 1 Job | 508 |
| | 5 HP - 10 HP (Three Phase) | 1 Job | 701 |
| | 10 HP - 15 HP (Three Phase) | 1 Job | 892 |
| | REPLACEMENT OF FLAT COPPER CABLE | | |
| 34.20.102 | Providing and fixing of ISI marked PVC insulated three core flat copper cable. | | |
| | 1.5 sq mm | 1 Job | 44 |
| | 2.5 sq mm | 1 Job | 67 |
| | 4.0 sq mm | 1 Job | 99 |
| | 6.0 sq mm | 1 Job | 144 |
| | HORIZONTAL / INCLINED / VERTICAL BORES INSIDE THE DUG WELL | | |
| 34.20.103 | Labour charges for lowering and taking out the drilling machine mast assembly, drill rods and drilling equipments etc. and installation of drilling machines mast inside the dug well Complete work. | Each | 3518 |
| 34.20.104 | Drilling of Horizontal / Inclined / Vertical bore hole of 115 mm diameter inside existing dug well up to desired depth with insertion of suitable perforated PVC/HDPE/ G.I. Pipe provided by department in all types of strata i.e. Soil, Rock, Hard Rock including all works pertaining to drilling such as transportation, installation and removal of drilling machine inside dug well etc. complete. | Per meter | 923 |
| | SINGLE/ THREE PHASE SUBMERSIBLE/ CENTRIFUGAL MOTOR PUMP SET | | |
| 34.20.105 | Supplying & Installation of Energy efficient five star | | |

| S.No. | Item | Unit | Rate in Rs. |
|---------|--|------|-------------|
| | BEE rating ISI Marked required capacity single phase, 50 Hz, 220V, deep well submersible pump Stainless Steel body, suitable for 4"/6" tube well with Contral Panel Starter suitable for Submersible pump with dry run protection, connections, including clamps, bore cap etc. as required as per specifications but excluding pipe, SS/Nylon wire rope and connection cable. | | |
| (i) | 0.5 H.P. with 6 to 7 stages, Head Mt. 46-13 Discharge LPM 10-55 | Each | 20898 |
| (ii) | 1 H.P. with upto 5 stages, Head Mt. 35-15 Discharge LPM 40-125 | Each | 22081 |
| (iii) | 1 H.P. with 7 to 8 stages, Head Mt. 61-18 Discharge LPM 25-90 | Each | 22456 |
| (iv) | 1 H.P. with 10 to 11 stages, Head Mt. 74-21 Discharge LPM 15-55 | Each | 23263 |
| (v) | 1 H.P. with 12 to 14 stages, Head Mt. 91-28 Discharge LPM 10-45 | Each | 23984 |
| (vi) | 1.5 H.P. with up to 6 stages, Head Mt. 42-17 Discharge LPM 65-150 | Each | 26228 |
| (vii) | 1.5 H.P. with up to 7 to 8 stages, Head Mt. 56-21 Discharge LPM 40-125 | Each | 26949 |
| (viii) | 1.5 H.P. with to 10 to 11 stages, Head Mt. 84-26 Discharge LPM 25-90 | Each | 26488 |
| (ix) | 1.5 H.P. with 16 to 17 stages, Head Mt. 114-33 Discharge LPM 15-55 | Each | 26574 |
| (x) | 1.5 H.P. with 18 to 20 stages, Head Mt. 130-41 Discharge LPM 10-45 | Each | 28535 |
| (xi) | 2 H.P. with up to 7 to 8 stages, Head Mt. 56-16 Discharge LPM 65-205 | Each | 30000 |
| (xii) | 2 H.P. with to 10 to 11 stages, Head Mt. 77-30 Discharge LPM 40-125 | Each | 30260 |
| (xiii) | 2 H.P. with 14 to 15 stages, Head Mt. 114-36 Discharge LPM 25-90 | Each | 29049 |
| (xiv) | 2 H.P. with 20 to 22 stages, Head Mt. 147-42 Discharge LPM 15-55 | Each | 28617 |
| (xv) | 2 H.P. with 25 stages, Head Mt. 163-58 Discharge LPM 10-45 | Each | 33288 |
| (xvi) | 3 H.P. with 10 to 12 stages, Head Mt. 84-23 Discharge LPM 65-205 | Each | 32192 |
| (xvii) | 3 H.P. with 15 to 17 stages, Head Mt. 119-45 Discharge LPM 40-125 | Each | 33162 |
| (xviii) | 3 H.P. with 20 to 22 stages, Head Mt. 167-51 Discharge LPM 25-90 | Each | 31846 |

| S.No. | Item | Unit | Rate in Rs. |
|-----------|--|---------|-------------|
| 34.20.106 | Supplying & Installation of Energy efficient five star BEE rating ISI Marked required capacity of Three Phase, 50 Hz, 415V, deep well submersible pump Steel body, suitable for 6" tube well with Control Panel Starter suitable for Submersible pump with dry run protection, single phase preventer, connections, including clamps, bore cap etc. as required as per specifications but excluding pipe and connection cable. | | |
| (i) | 3 H.P. with up to 6 stages, Head Mt. 55-7 Discharge LPM 60-510 | Each | 36173 |
| (ii) | 5 H.P. with up to 5 stages, Head Mt. 55-13 Discharge LPM 120-510 | Each | 40584 |
| (iii) | 5 H.P. with 8 to 9 stages, Head Mt. 83-32 Discharge LPM 60-270 | Each | 43354 |
| (iv) | 5 H.P. with 10 to 11 stages, Head Mt. 101-40 Discharge LPM 60-270 | Each | 45776 |
| (v) | 7.5 H.P. with 8 to 10 stages, Head Mt. 117-31 Discharge LPM 60-420 | Each | 50682 |
| (vi) | 7.5 H.P. with 13 to 14 stages, Head Mt. 129-52 Discharge LPM 60-270 | Each | 57651 |
| (vii) | 7.5 H.P. with 15 stages, Head Mt. 138-60 Discharge LPM 60-270 | Each | 59872 |
| (viii) | 10 H.P. with 16 stages, Head Mt. 147-64 Discharge LPM 60-270 | Each | 63102 |
| (ix) | 10 H.P. with 20 stages, Head Mt. 184-80 Discharge LPM 60-270 | Each | 69563 |
| 34.20.107 | Supplying and laying of submersible flat cable ISI marked 3 core copper wire of suitable size with proper clamping of approved make. | | |
| (i) | 2.5 Sq.mm. multi strand | Per Mtr | 121 |
| (ii) | 4.0 Sq.mm. multi strand | Per Mtr | 170 |
| (iii) | 6.0 Sq.mm. multi strand | Per Mtr | 251 |
| (iv) | 10.0 Sq.mm. multi strand | Per Mtr | 405 |
| 34.20.108 | Supplying and laying of approved Make Nylon rope 12mm thick complete with binding for support of pump and motor | Per Mtr | 61 |
| 34.20.109 | Supplying and laying of approved make stainless steel wire rope 6 mm thick complete with binding for support of pump and motor | Per Mtr | 139 |

| S.No. | Item | Unit | Rate in Rs. |
|--------------|---|-------------|--------------------|
| 34.20.110 | Supplying and Installation of approved Make required capacity single phase, 50 Hz, 220V, Centrifugal Mono-block pump self priming, with Starter, connections, base channel foundation etc. as required as per specifications but excluding Pipe and connection cable. | | |
| (i) | 1 H.P. Head Mt.6-30, Discharge LPH 2400-900 | Each | 12001 |
| (ii) | 1 H.P. Head Mt.21-45, Discharge LPH 1800-400 (Domestic Model) | Each | 7453 |
| 34.20.111 | Supplying & Installation of approved Make required capacity single phase, 50 Hz, 240V, Centrifugal Mono-block pump, with Starter, connections, base channel foundation etc. as required as per specifications but excluding Pipe and connection cable. | | |
| (i) | 1.0 H.P. Head Mt.3-24, Discharge LPH 27000-1500 | Each | 11505 |
| (ii) | 1.5 H.P. Head Mt.3-21, Discharge LPH 39600-6000 | Each | 13820 |
| (iii) | 2.0 H.P. Head Mt.3-18, Discharge LPH 48600-3000 | Each | 15341 |
| 34.20.112 | Supplying & Installation of approved Make required capacity 3 phase, 50 Hz, 415V, Centrifugal Mono-block pump, with Starter, i/c single phase preventor, connections, base channel foundation etc. as required as per specifications but excluding Pipe and connection cable. | | |
| (i) | 3.0 H.P. Head Mt.6-15, Discharge LPM 740-465 | Each | 19396 |
| (ii) | 5.0 H.P. Head Mt.6-33, Discharge LPM 1380-450 | Each | 23762 |
| (iii) | 7.5 H.P. Head Mt.24-37, Discharge LPM 780-320 | Each | 30419 |
| 34.20.113 | Supplying & Installation of Five star BEE rating ISI Marked required capacity of Three phase, 50 Hz, 415V, Open well Submersible pump, with Control Panel Starter with Dry Run Protection, single phase preventer, connections, etc. as required as per specifications but excluding pipe and connection cable. | | |
| (i) | 3.0 H.P. Head Mt.15-24, Discharge LPM 615-195 | Each | 22626 |
| (ii) | 5.0 H.P. Head Mt.15-24, Discharge LPM 930-420 | Each | 24319 |

ANNEXURE-1

**ISSUE RATES OF ISI MARK HAND PUMPS.
G.I. RISER, G.I. CASING & UPVC CASING PIPES FOR
PREPARATION OF ESTIMATES ONLY**

| S.No. | Item | Unit | Rate in Rs. |
|-------|--|-------|-------------|
| 1 | ISI mark India mark-II deep well hand pump complete with 10 Nos. MS connecting rods. (12 mm x 3 M long) Normal stand assembly as per, Part-C, General Note: 27.28.9 | Each | 8132 |
| 2 | ISI mark India mark-II deep well hand pump complete with 10 Nos. MS connecting rods. (12 mm x 3 M long) telescopic stand assembly, Part-C, General Note: 27.28.9 | Each | 8275 |
| 3 | ISI Mark 32 mm dia. G.I. riser pipe in 3 meter length socketed on one end as per I.S. 1239 (Part I) 1990 up-to-date amendments and socket as per I.S. 2062/1990 up-to-date amendment, Part-C, General Note: 27.28.10 | Meter | 200 |
| 6 | ISI marked G.I. casing pipe (Plain) medium class in 4 to 7 meters length one end fitted with socket as per I.S.: 1239 (Part-2) 1992 with IV th revision (Up-to-date amendments), Part-C, General Note: 27.28.10 | | |
| | 100 mmdia | Meter | 802 |
| | 125 mmdia | Meter | 1046 |
| | 150 mmdia | Meter | 1251 |
| 7 | ISI marked UPVC casing pipe Confirming to IS 12818/92 (with up-to-date amendments), Part-C, General Note: 27.28.11 | | |
| | CM casing pipes, 125 mm dia | Meter | 463 |
| | CM casing pipes, 150 mm dia | Meter | 562 |
| | CS casing pipes, 150 mm dia | Meter | 482 |

STRATA - CHART

District BlockPanchayat.....
 Name of Revenue village..... Name of habitation
 Name of Contractor Registration no. of machine
 Agreement No. Work Order No.....
 Date of starting of Tube well construction.....
 Date of completion of tube well construction
 Name of Sub-Engineer in charge of work
 Measurement Book Number.....
 Exact location of drilling

| Ground | Level | <u>Details</u> |
|--------|--------|--|
| Depth | Strata | 1. Type of tube well----- 2. Diameter of tubewell----- mm 3. Total depth of tubewell ----- mt. 4. Details of casing pipe Type (G.I/ UPVC/ BLANK/SLOTTED) Diameter..... mm Lengthmeter 5. Static water level in the tubewell----- mt. 6. Type of pump installed ----- 7. Length of riser pipe installed Type (G.I/UPVC)----- mt. 8. Yield of tube well ----- 9. Draw down at above yield -----mt. |

Signature of contractor

Signature of
 Sub-Engineer
 Office

Signature of
 Assistant Engineer
 Office.....

GEOPHYSICAL RESISTIVITY SURVEY REPORT

1. District BlockPanchayat.....
2. Nameofvillage..... Name of habitation.....
3. Name of Hydrogeologist.....Registration no. & Date of Validity.....
4. Agreement No & Date.Work Order No.....No. of Survey allotted.....
5. Date of Survey: -
6. Name of PHED Person (Mechanic/SubEng./DC/BC):
7. Model No & Make of Resistivity meter used forsounding.....
8. Resistivity Survey Purpose:-..HP/PWSS
9. Toposheet No/HGM No.: --
10. Geomorphology of thearea:- Valley/PLW/PLM/PLU/PPS
11. Geological Succession of the area under investigation :- Alluvium/Basalt/Granite/others
12. Hydrogeology of the area:- River system following & Static watertable
13. Details of the Resistivity Survey : No. of VES- 03 (Interpretation by Schlumberger method)

| Vertical Electric Sounding data | Latitude / Longitude ofVES | App. Resistivity of layer in ohm (m) | | | | Thickness of layer in (m) | | | | Total depth (m) |
|---------------------------------|----------------------------|--------------------------------------|----------------------|----------------------|----------------------|---------------------------|----|----|----|-----------------|
| | | ρ_1 (in Ohm-m) | ρ_2 (in Ohm-m) | ρ_3 (in Ohm-m) | ρ_4 (in Ohm-m) | h1 | h2 | h3 | h4 | H |
| VES No. I | | | | | | | | | | |
| VES No. II | | | | | | | | | | |
| VES No. III | | | | | | | | | | |

Subsequently, the above interpretation on the layers identified are geologically Presented in the following sequence:

15. Recommended site :-

- i. Location of Site:----- Longitude E: ----- Latitude N: -----
- ii. Direction of site from Village.....

| S.No | Characteristics:- Sub-Surface Strata (Litholog) expected. | Depth below Ground Level (m) | | Aquifer (I, II, III) | Shallow/Deeper Aquifer |
|------|---|------------------------------|----|-----------------------|------------------------|
| | | From | To | | |
| | | | | | |
| | | | | | |
| | | | | | |

- iii. Type of drilling machine :-D.T.H./combination bore/GravelPack
- iv. Diameter of T/W:-
- v. Depth of Tube well :-.....mt
- vi. Expected Casing (Compact & Perforated) requirement : -----to----mt/ ---to--mt/ ---to --mt.
- vii. Expected Yield :-LPH (Liter PerHour)
- viii. Remarks:
- ix. Suggestive Recharge Structure:-

16. Enclosures:-

- (i) Photocopy of Toposheet / HGM Map of area.
- (ii) Map (Not to scale) showing the location of Survey Point (to be attached separately) in A4 size sheet.
- (iii) Location site plan of three sounding sites
- (iv) Reading chart of Sounding
- (v) Depth probe graph/curves.
- (vi) Photograph of site with installed instrument
- (vii) Detail of Private Tube well nearby:

| S. No. | Location of Tube well | Depth (m) | Yield (LPH) |
|--------|-----------------------|-----------|-------------|
| | | | |
| | | | |
| | | | |

Signature of AE/Sub Eng. / DC(Hydrologist) Signature of Geo-hydrologist & Seal

YIELD TEST OF TUBE WELLS.

District BlockPanchayat.....

Name of Revenue village..... Name of habitation.....

Name of contractor.....

Agreement No. Work order No.....

Date of yield test.....

Diameter of tube well Depth of tube well.....

Static water level in tube well

Type and K.W. of pumping set used for yield test.....

Type of measuring device used for measurement of discharge.....

Depth at which the pumping set installed.....

Time at which the yield test started.....

Sketch of casing pipe with measuring point

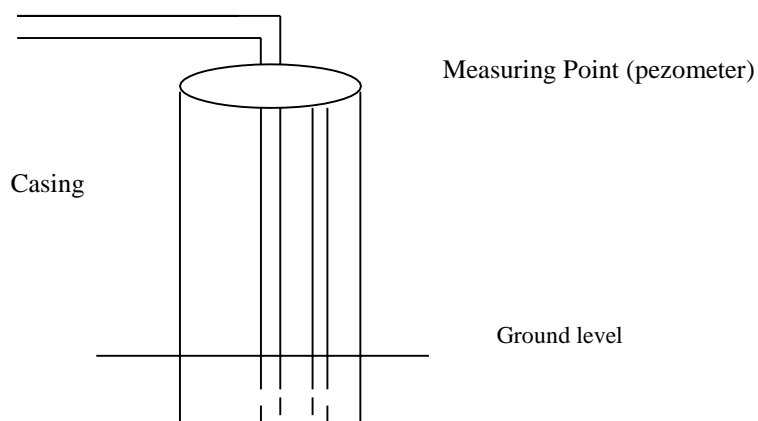

Pump Test Results

| S. No. | Time | Step No. | Duration of step (hrs.) | Discharge (cu. mtr. / hr.) | Water level in the tube well measured from ground level at the end of each step in meters | Draw Down in meters = static water level (-) water level at the end of pumping at given time | Remark |
|--------|------|----------|-------------------------|----------------------------|---|--|--------|
| 1 | | | | | | | |
| 2 | | | | | | | |
| 3 | | | | | | | |
| 4 | | | | | | | |
| | | | | | | | |

Note:- Discharge at static water level shall be taken on dependable yield of Tube well.

Signature of Contractor

Signature of Sub-Engineer

Signature of Assistant Engineer

PART (D)

DRAWINGS

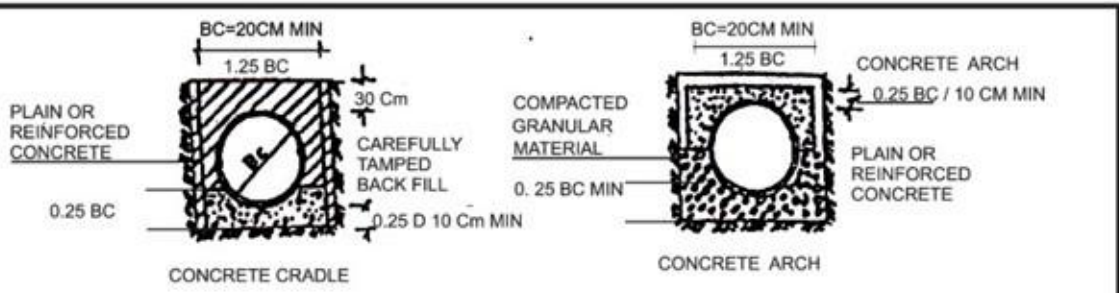

CLASS A

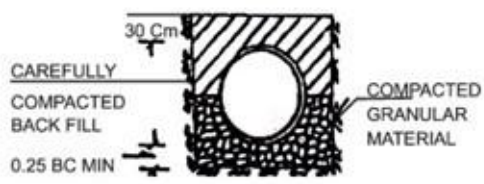

Compacted Granular Bedding

CLASS B

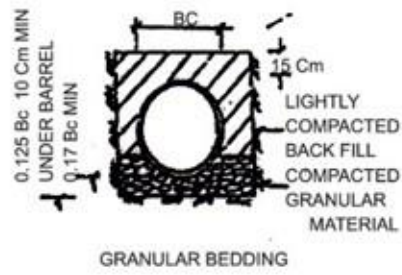

CLASS C

FIG 1. CLASSES OF BEDDING FOR CONDUIT IN TRENCH

NOTE : IN ROCK, TRENCH IS EXCAVATED ATLEAST 15 Cm BELOW THE BELL OF THE EXCEPT WHERE CONCRETE CRADLE IS USED.

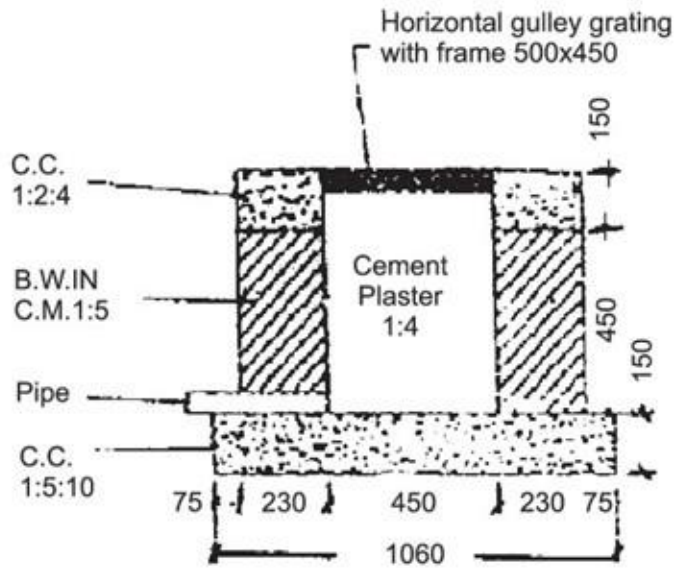

**ROAD GULLEY CHAMBER
450X500 X600 (HORIZONTAL)
FIGURE 2**

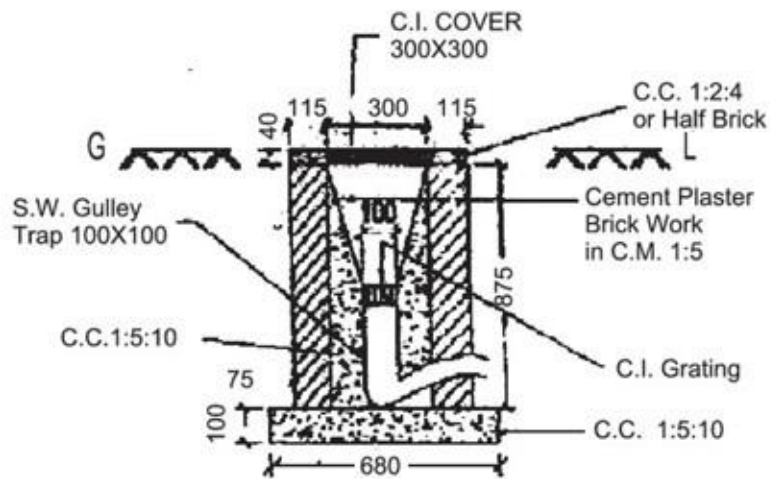

**GULLEY TRAP CHAMBER
FOR 100X100 mm.
GULLY TRAP
FIGURE - 3**

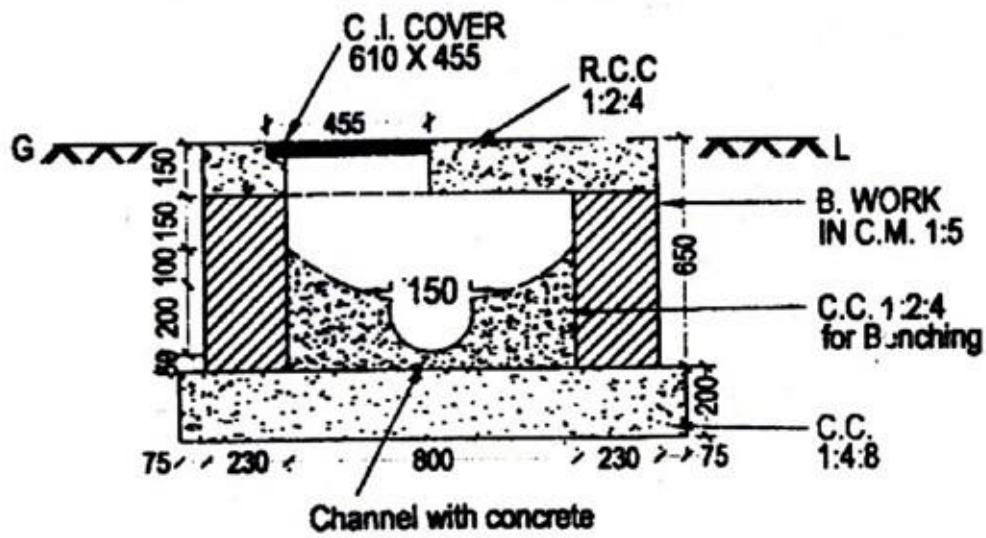

MAN HOLE 900X800X450
FIGURE - 4

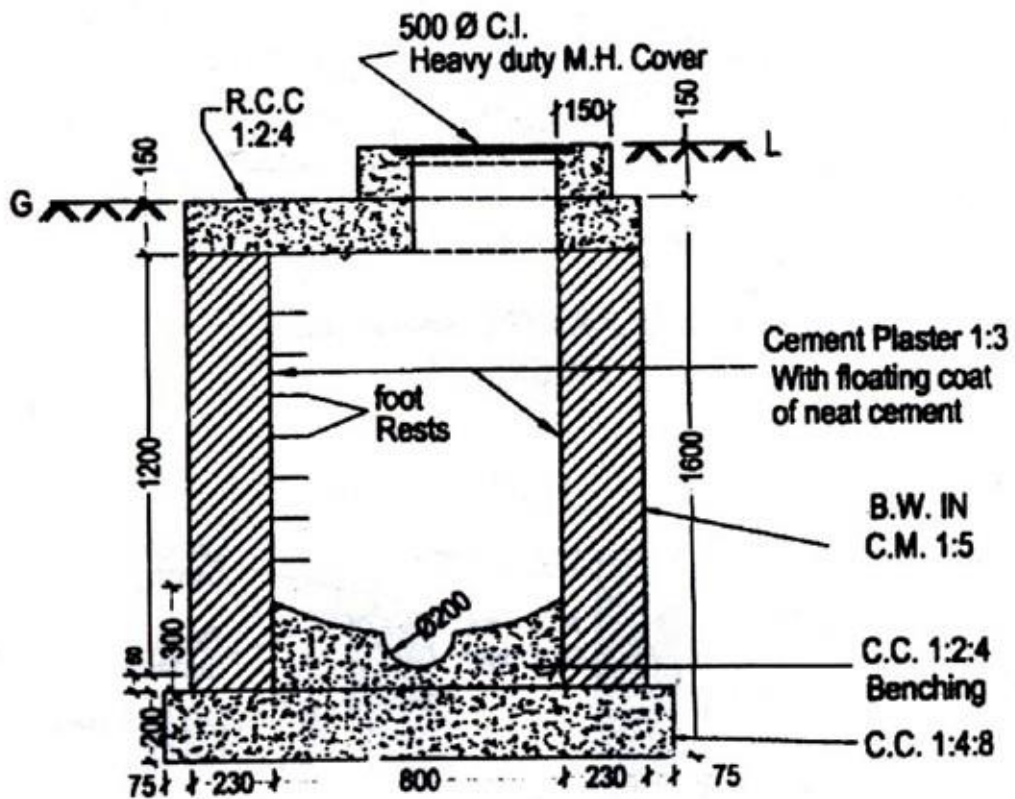

MAN HOLE 1200X800X800
FIGURE - 5

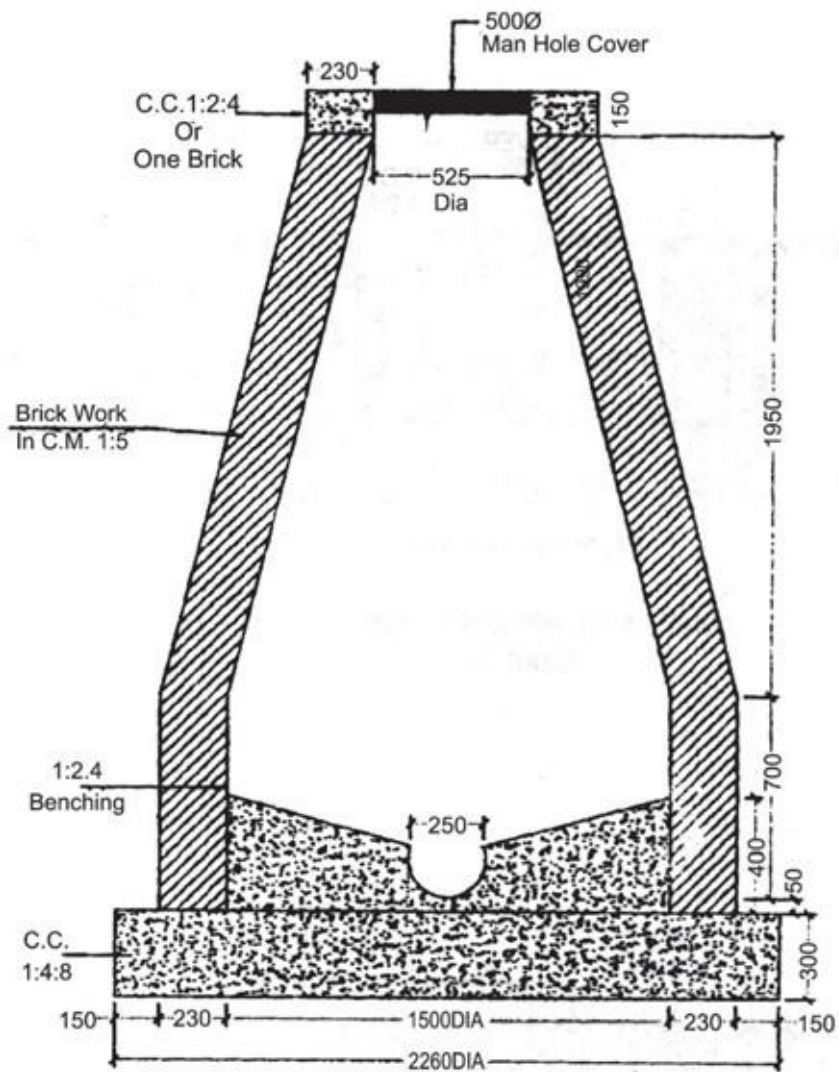

CIRCULAR TYPE MAN HOLE

FIGURE -6

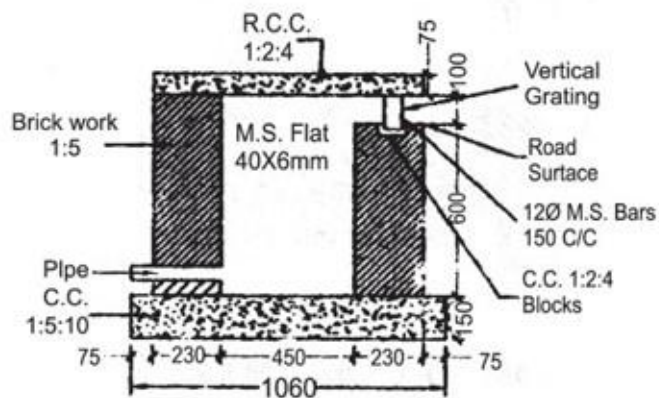

ROAD GULLEY CHAMBER
400X450X775 (VERTICAL GRATING)

FIGURE -7

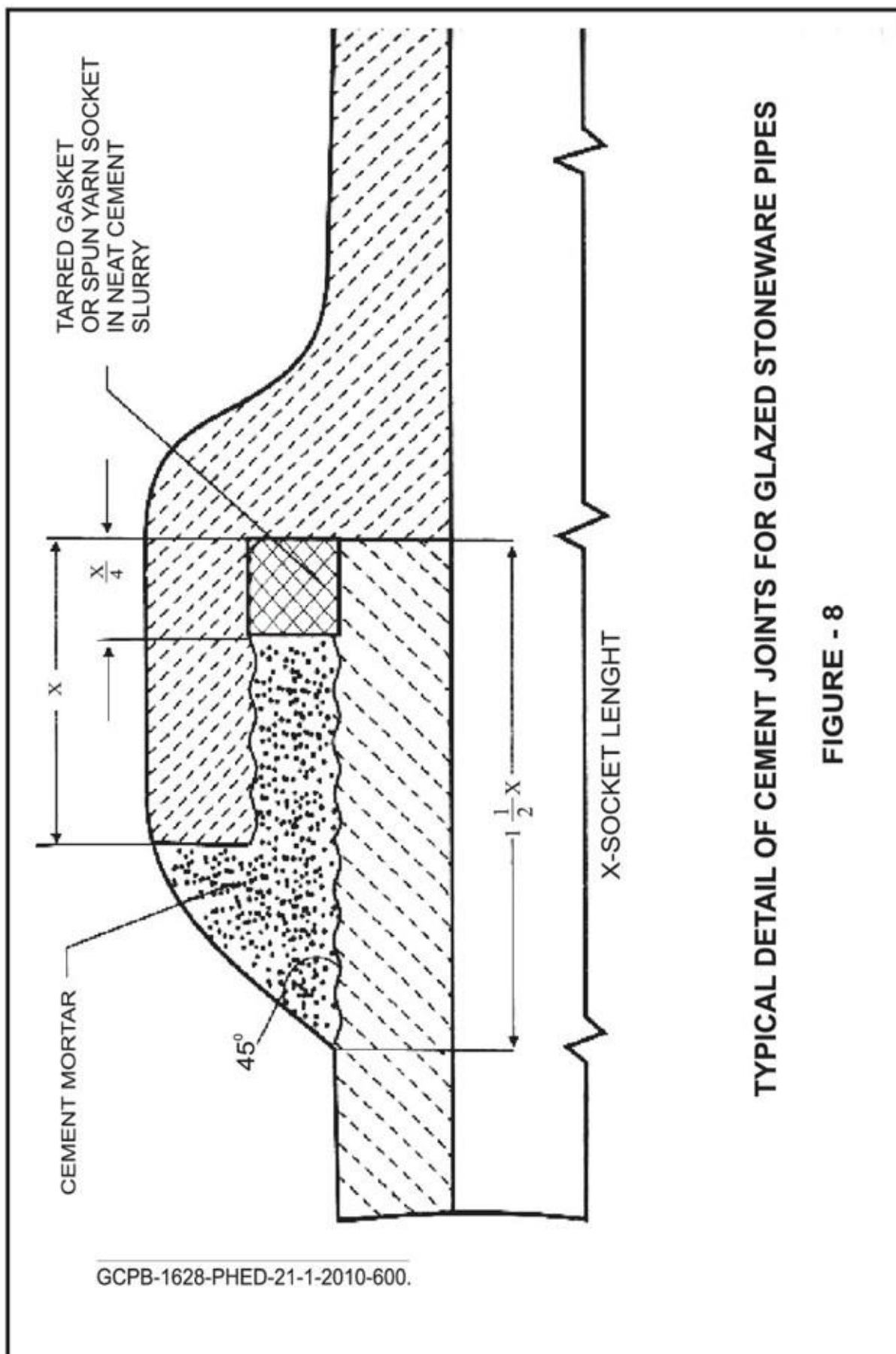

TYPICAL DETAIL OF CEMENT JOINTS FOR GLAZED STONEWARE PIPES

FIGURE - 8

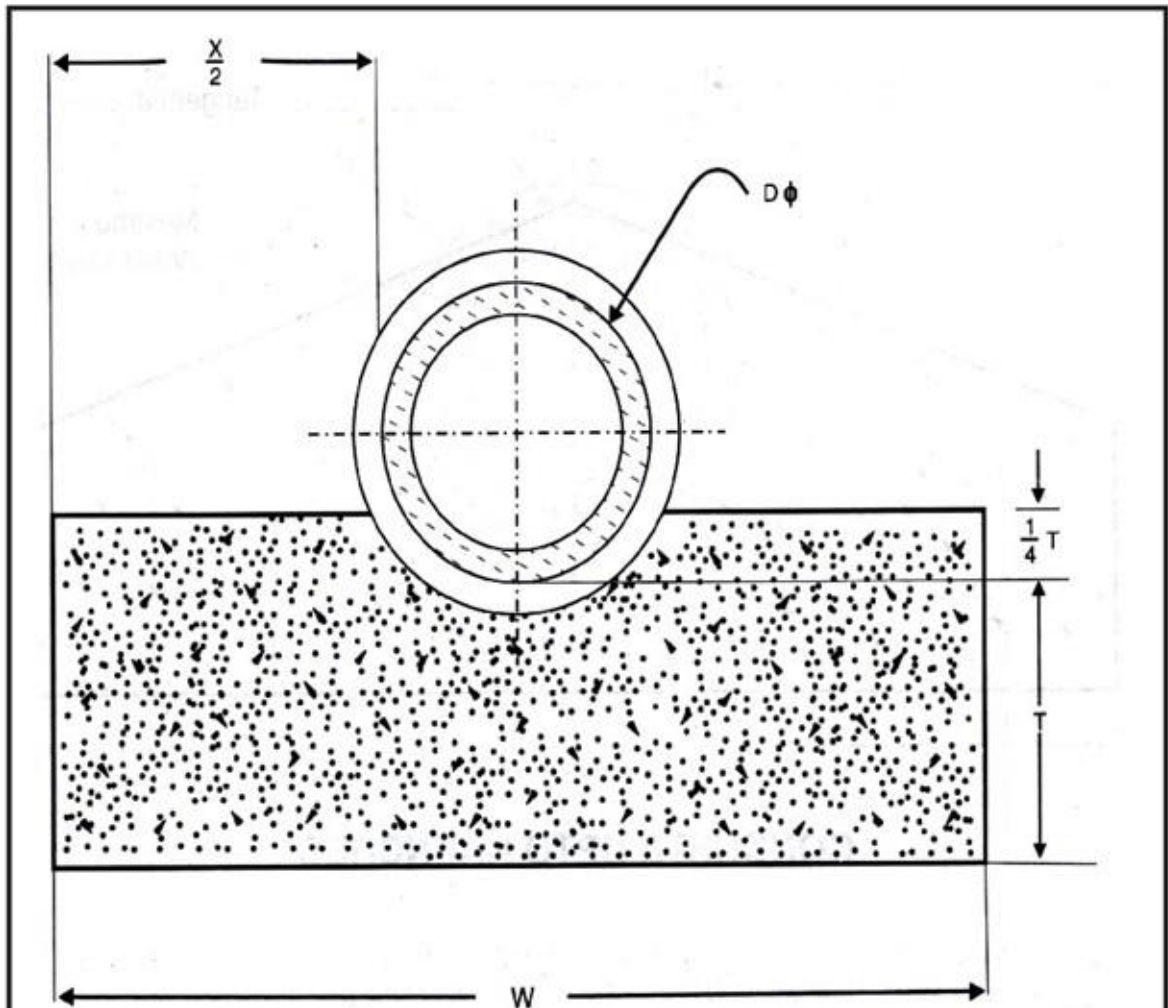

BEDDING

- $W = D+X$, where D is the external diameter of the pipe.
 $X =$ 300mm upto trench depth of 1200mm
 400mm for trench depth more than 1200mm
 $T =$ 100 mm for pipes under 150mm
 1/4th internal dia. subject to a min. of 150mm and max.
 300 mm. for pipes more than 150 mm dia.

FIGURE - 9

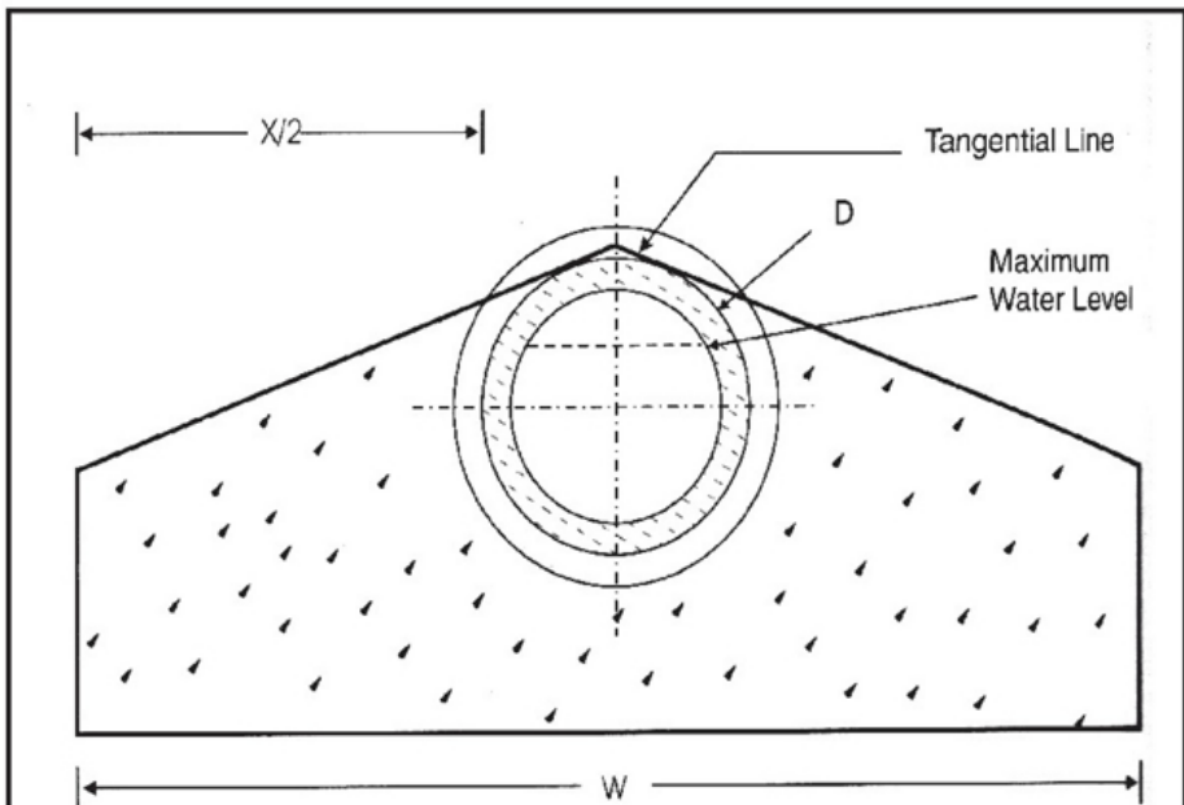

CONCRETE UPTO HAUNCHES

- $W = D+X$, where D is the external diameter of the pipe.
- $X = 300\text{mm}$ upto trench depth of 1200mm
 400mm for trench depth more than 1200mm
- $T = 100\text{ mm}$ for pipes under 150mm
 $1/4\text{th}$ internal dia. subject to a min. of 150mm and max.
 300 mm . for pipes more than 150 dia .

FIGURE - 10

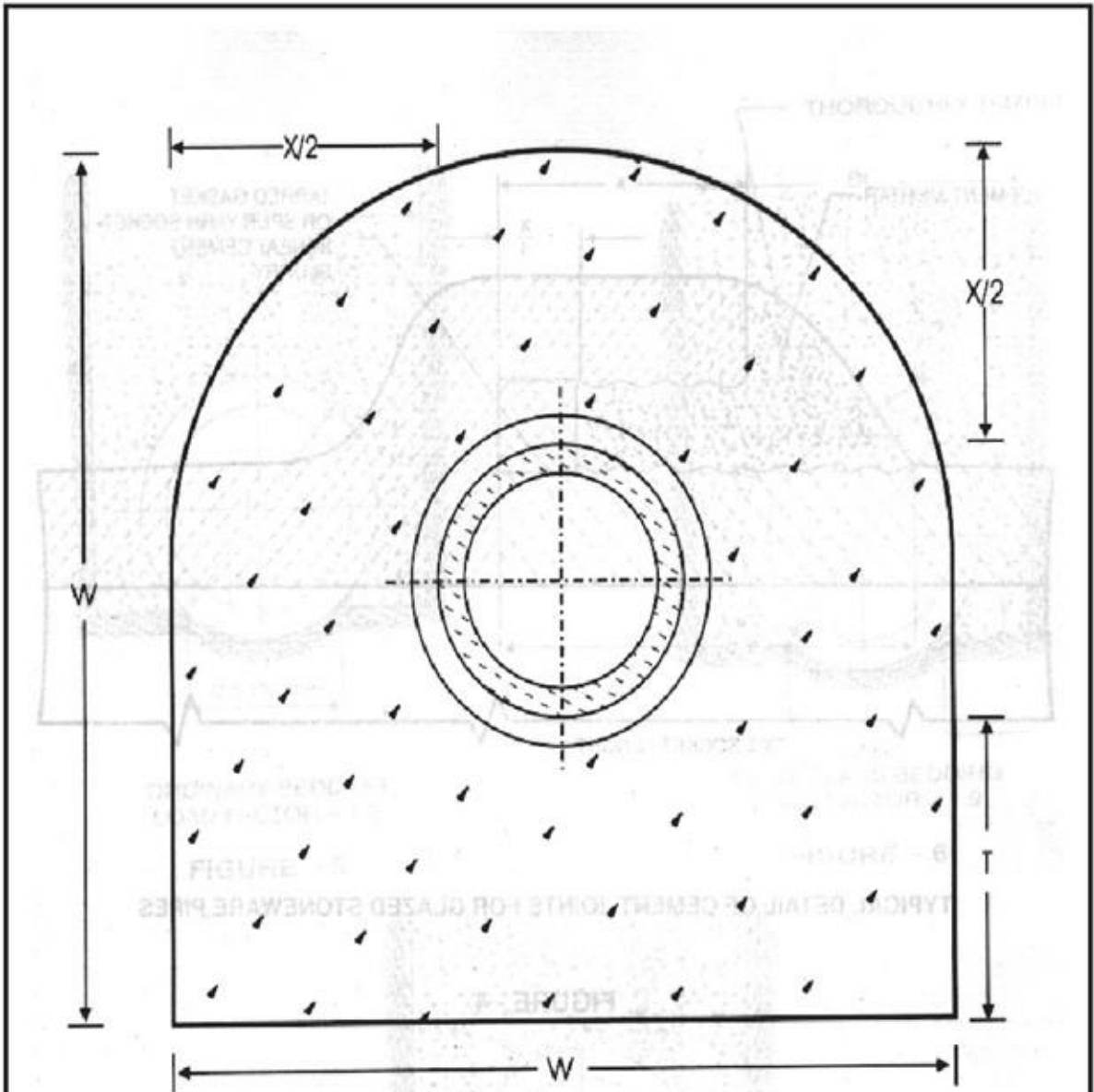

CONCRETE AROUND

- T = 100 mm for pipes under 150mm
1/4th internal dia. subject to a min. of 150mm and max. 300 mm. for pipes more than 150 dia.
- W = D+X. where D is the external diameter of the pipe.
- X = 300mm upto trench depth of 1200mm
400mm for trench depth more than 1200mm

FIGURE - 11

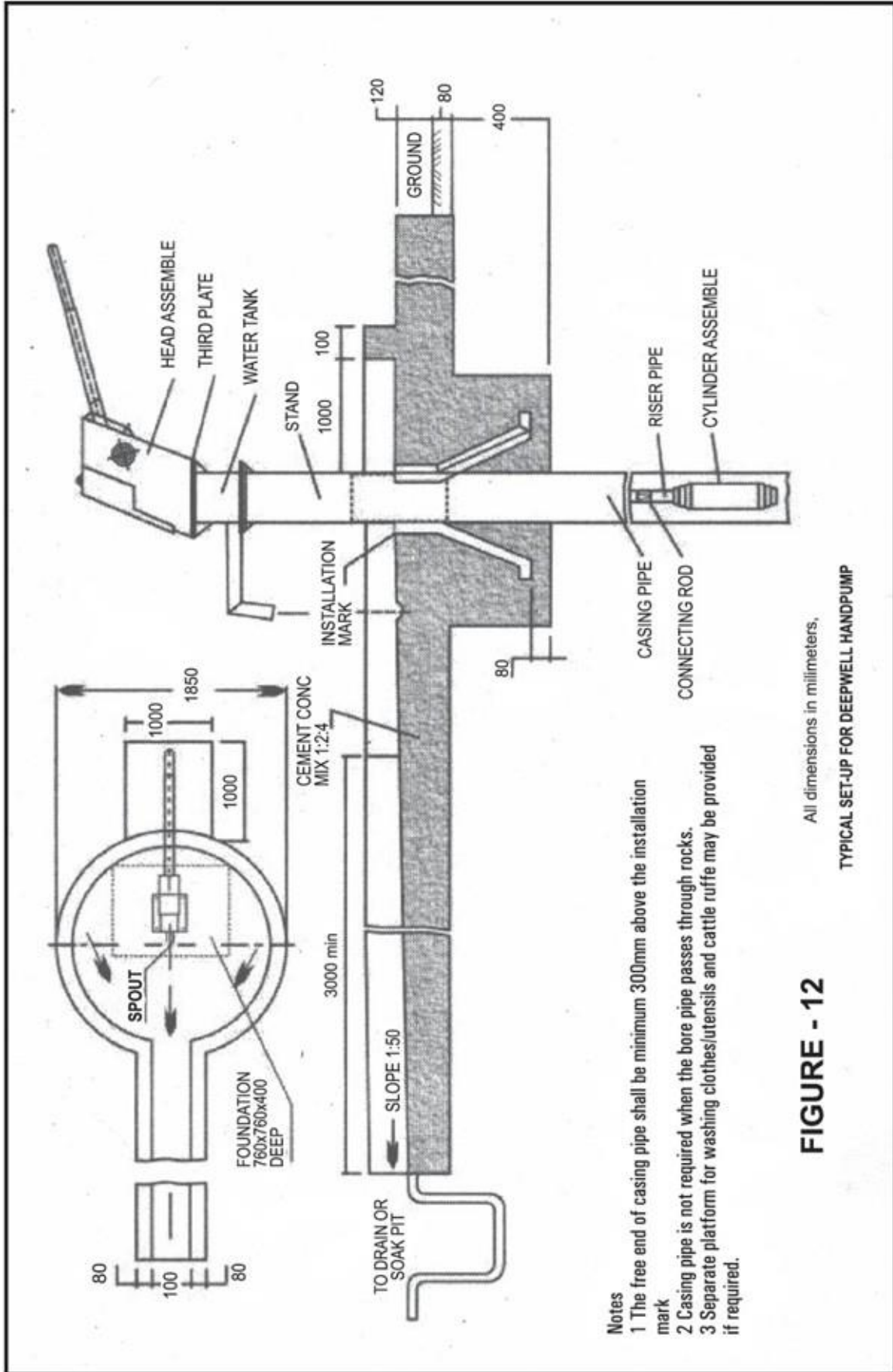

Notes

- 1 The free end of casing pipe shall be minimum 300mm above the installation mark
- 2 Casing pipe is not required when the bore pipe passes through rocks.
- 3 Separate platform for washing clothes/utensils and cattle ruffe may be provided if required.

FIGURE - 12

All dimensions in millimeters.

TYPICAL SET-UP FOR DEEPWELL HANDPUMP

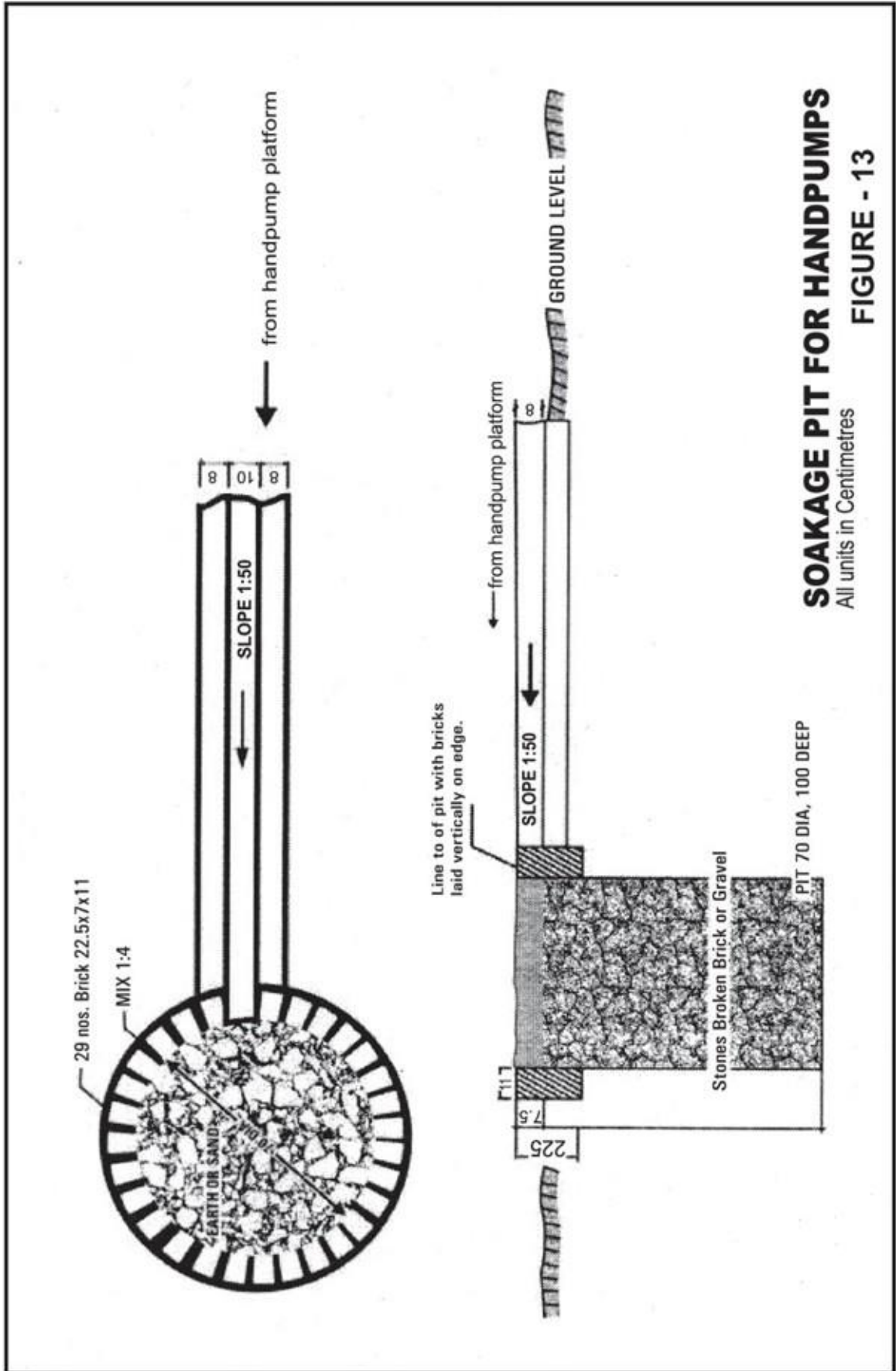

SOAKAGE PIT FOR HANDPUMPS

All units in Centimetres

FIGURE - 13

ORDINARY TUBEWELL

125 / 115 mm.dia

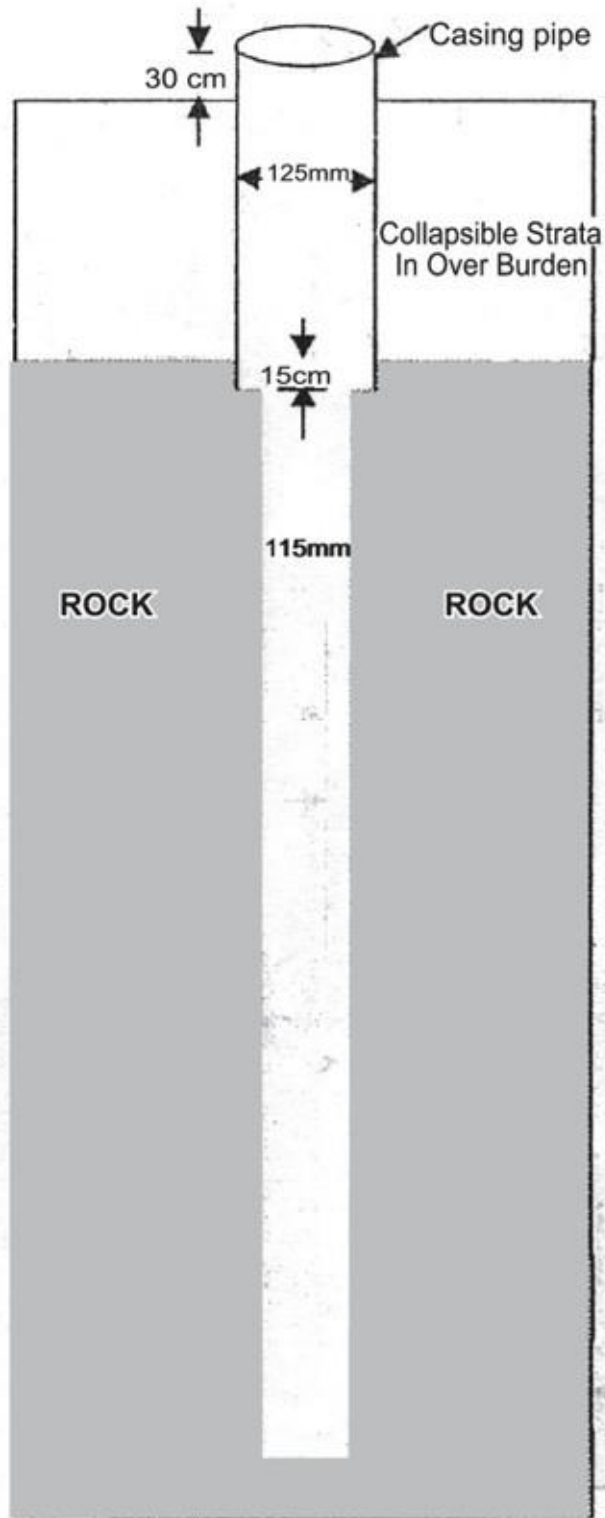

FIGURE - 14

ORDINARY TUBEWELL

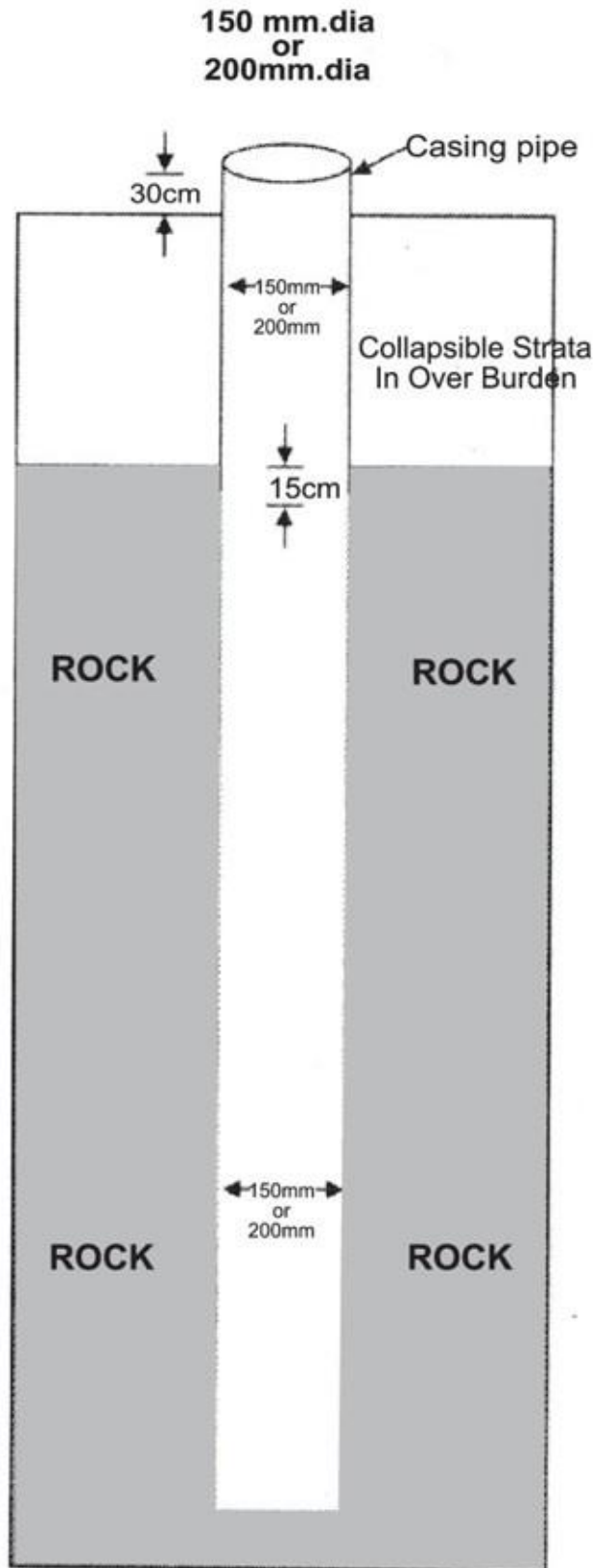

FIGURE - 15

200/150/125 mm dia. TUBEWELL

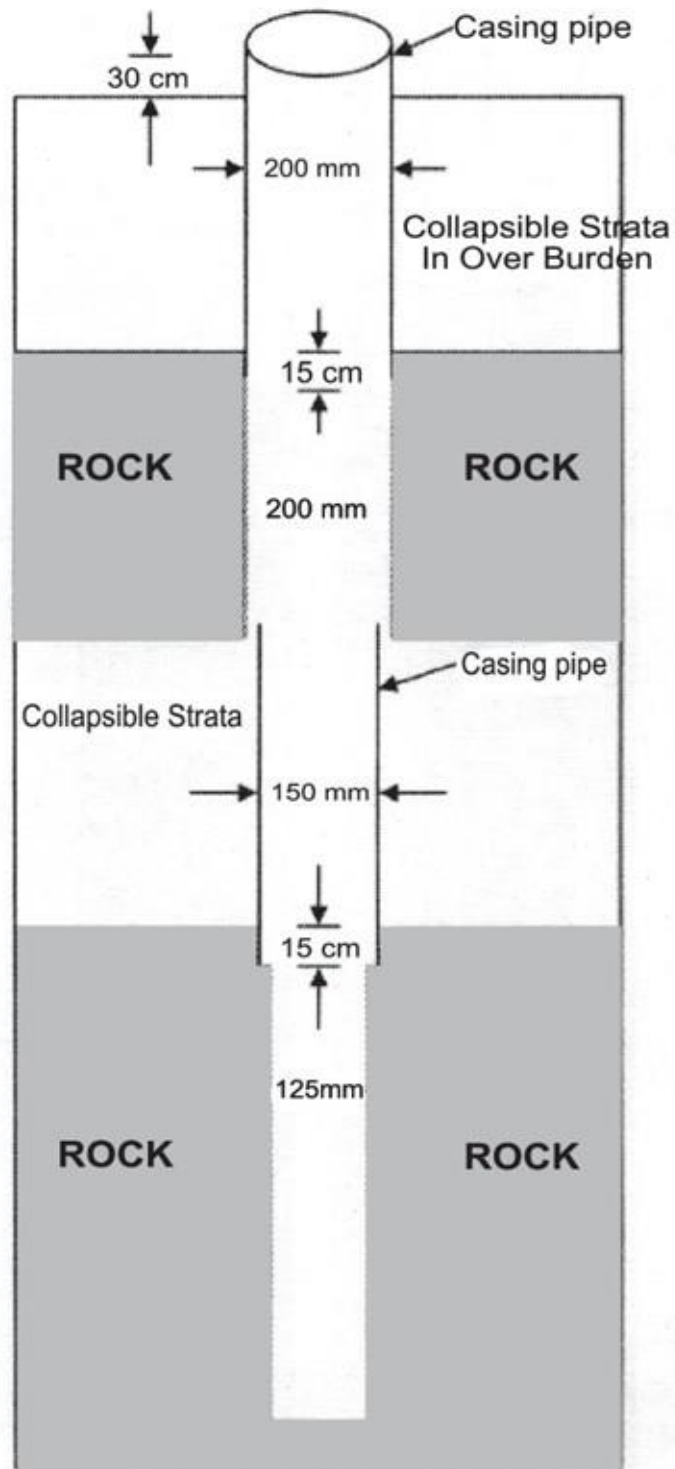

FIGURE - 16

150/125/115 mm dia. TUBEWELL

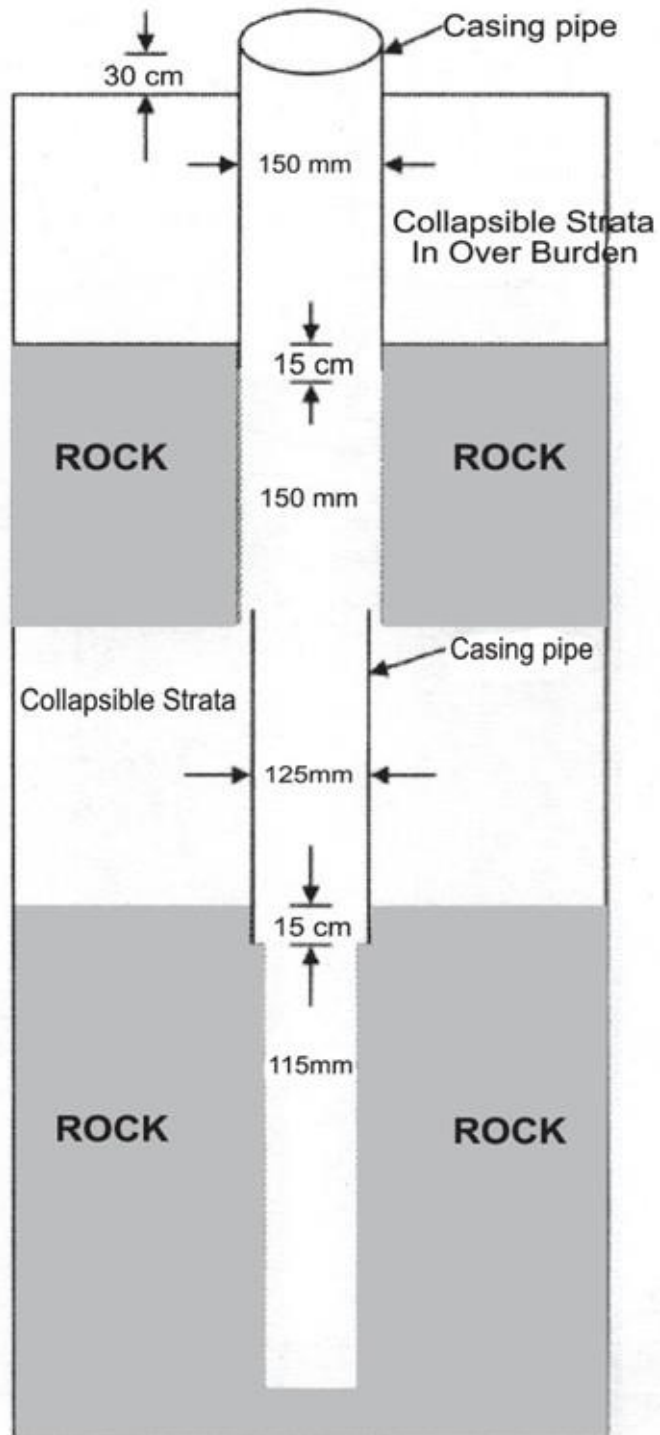

FIGURE - 17

Gravel Pack Tubewell

300 or 350 or 400mm
300
350/400mm

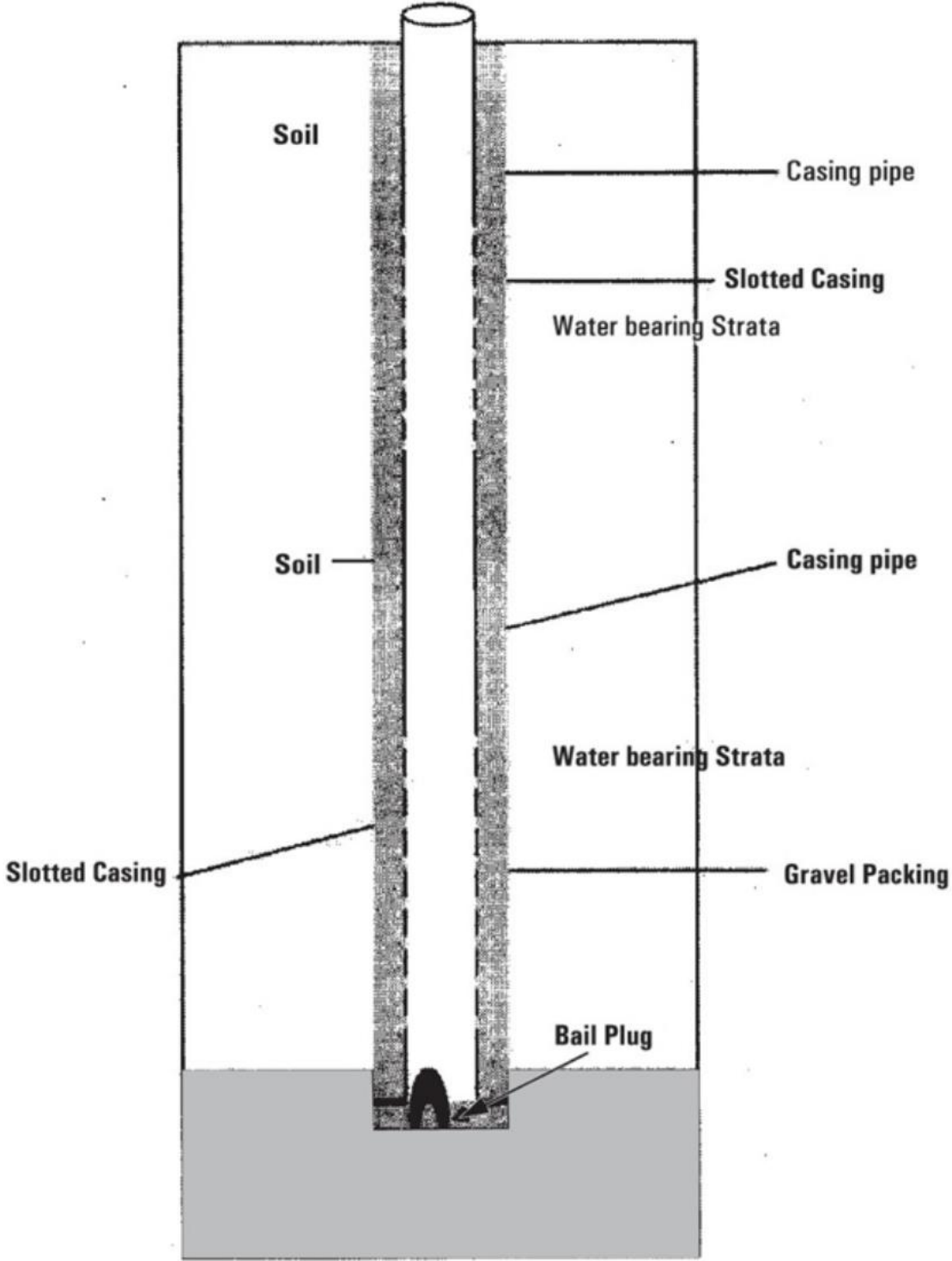
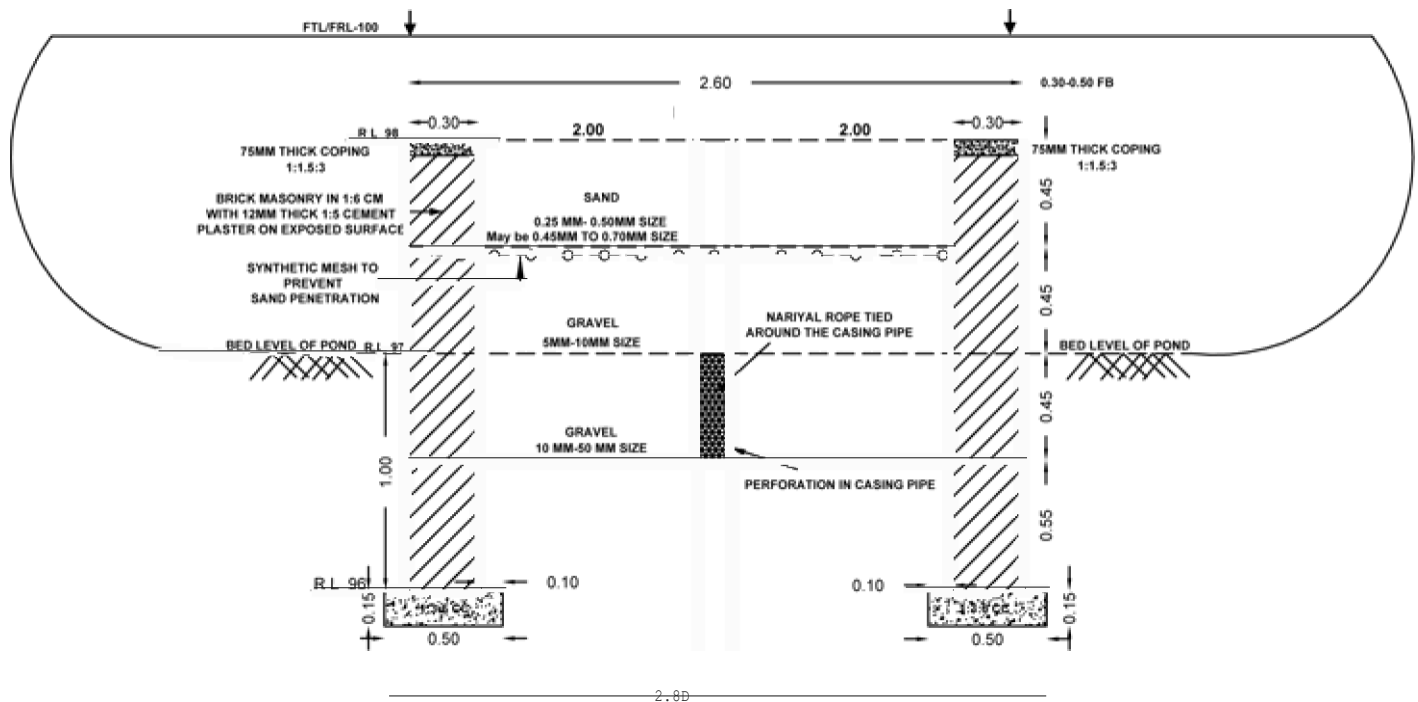

FIGURE - 18

DRAWING FOR CONSTRUCTION OF RECHARGING PIT ONLY FOR
CONSTRUCTION OF RECHARGING SHAFT IN SUBMERGENCE



NDTE :-

1. ALL DIMENSION IN METERS
2. MINIMUM CASING IN RECHARGE SHAFT SHALL BE 9.60M OR UPTO HARD STRATA IT IS TO PREVENT ENTRY OF POLLUTED WATER IN AQUIFER
3. RECTANGULAR PITS WITH INTERNAL SIZE = 2.60M X 1.00M TO SCALE

RECHARGE SHAFT WITH VERTICAL FILTER TO BE CONSTRUCTED IN
THE SUBMERGENCE OF RESERVOIR

DRAWING FOR CONSTRUCTION OF RECHARGING PIT WITH STEINING AND CATCH DRAIN AROUND TUBE WELL

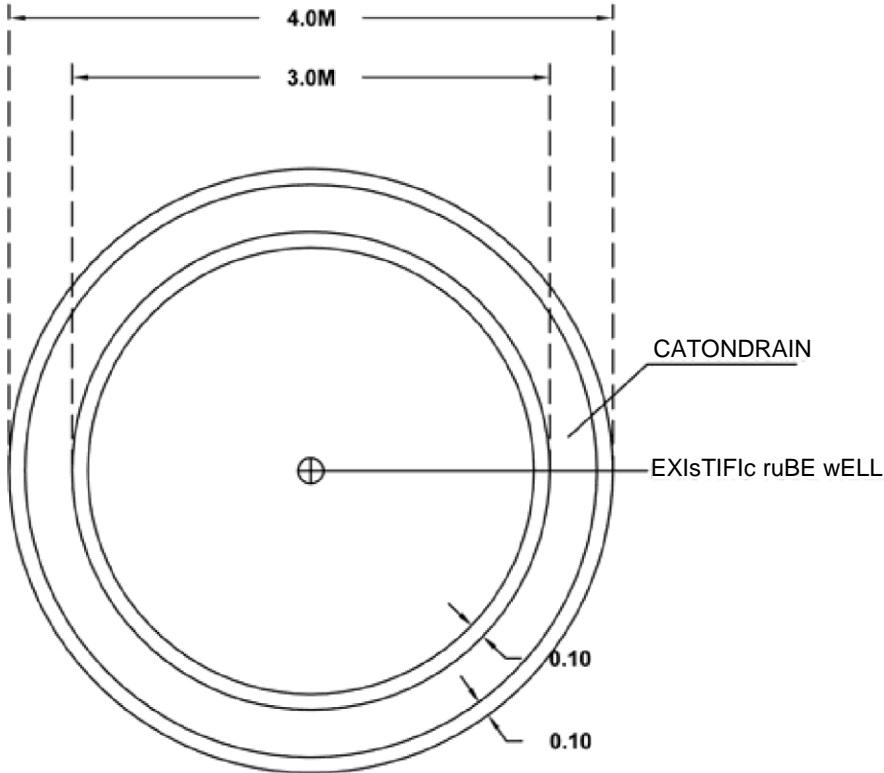

PLAN

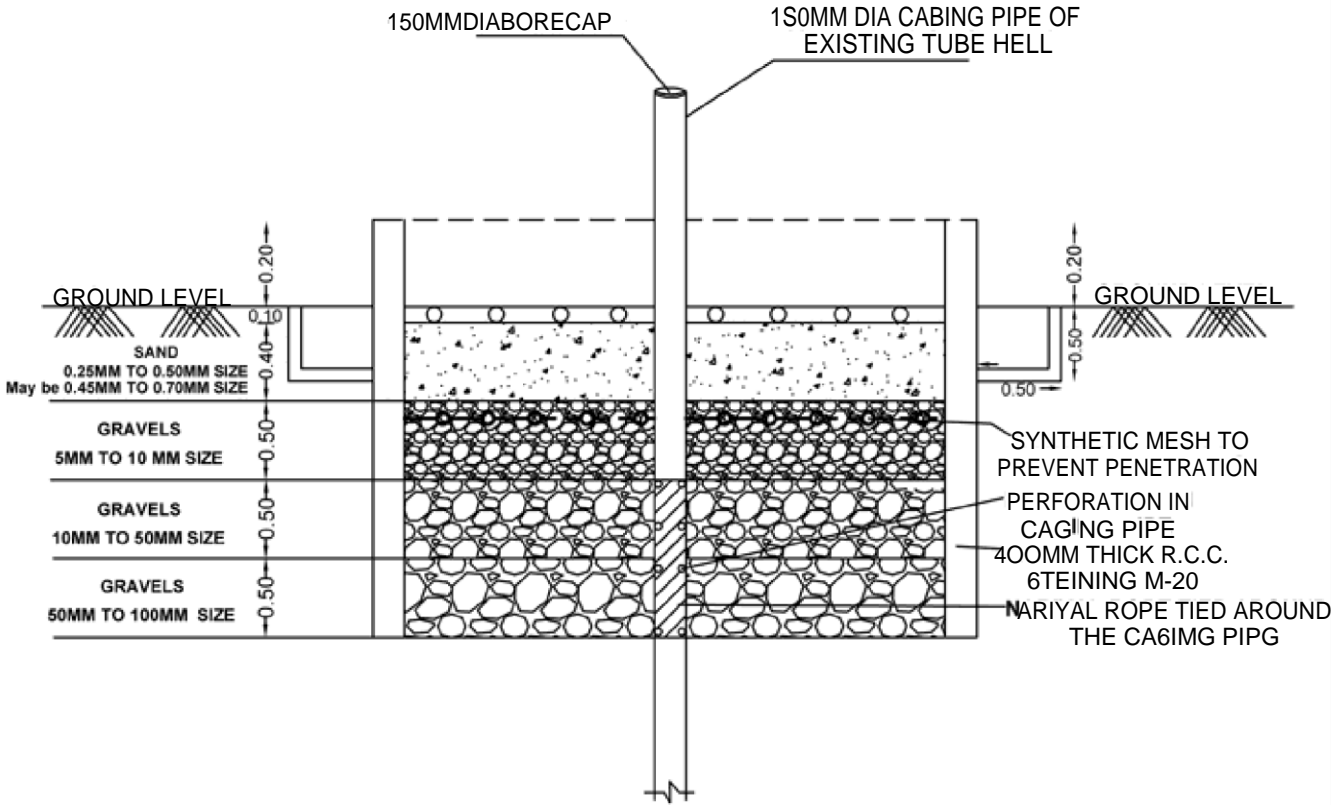

SECTIONAL ELEVATION

ALL DIMENSION IN METERS

NOT TO SCALE

DRAWING FOR CONSTRUCTION OF RECHARGING PIT AROUND TUBE WELL, IN SOFT/HARD ROCK AREA

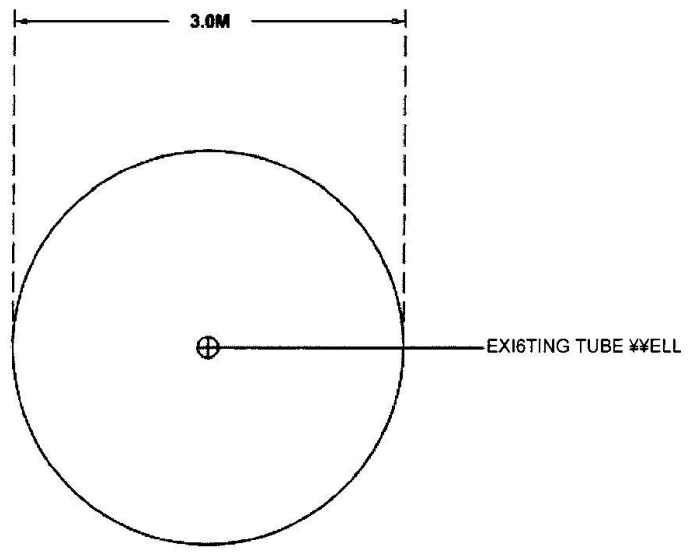

PLAN

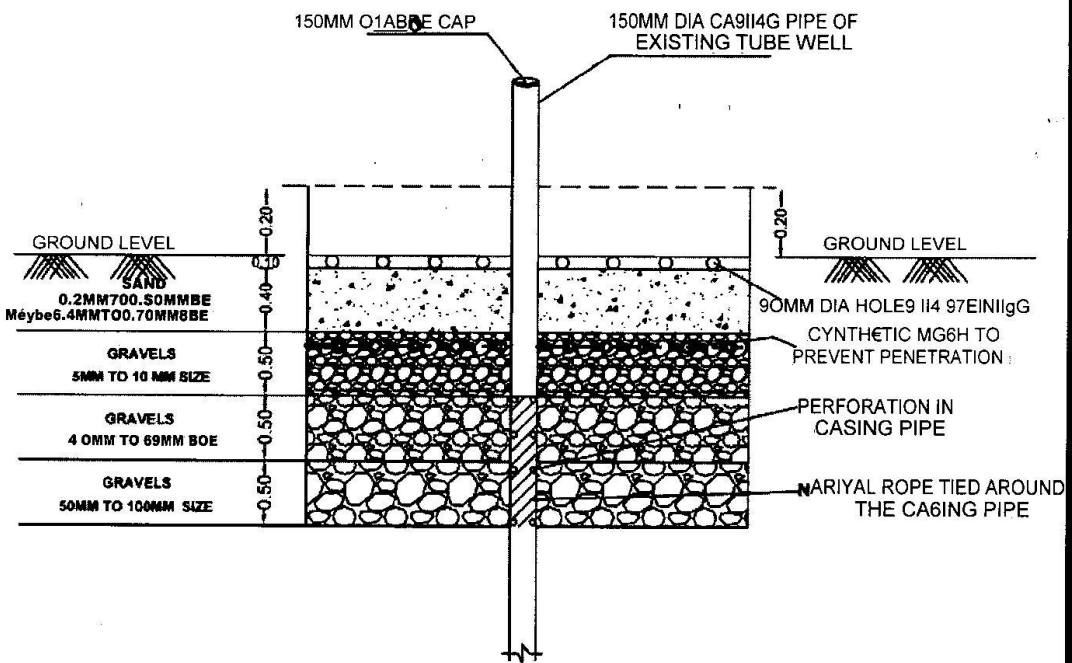

SECTIONAL ELEVATION

ALL DIMENSIONS IN METERS

NOT TO SCALE

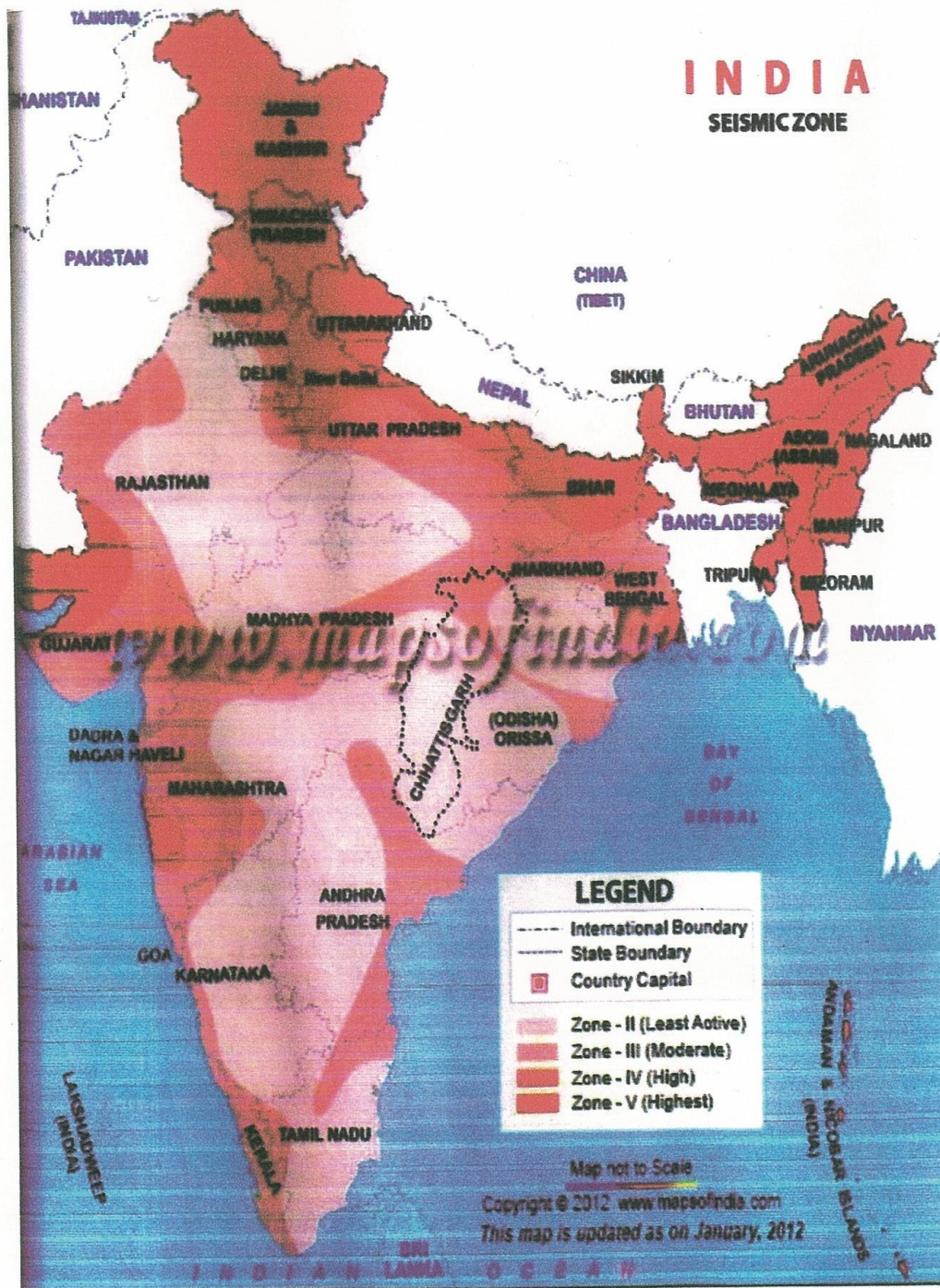

FHTC UNDER JJM CHHATTISGARH

Layout of Pipe Line Network From Main Line To Service Connection For Household

PRODUCED BY AN AUTODESK EDUCATIONAL PRODUCT

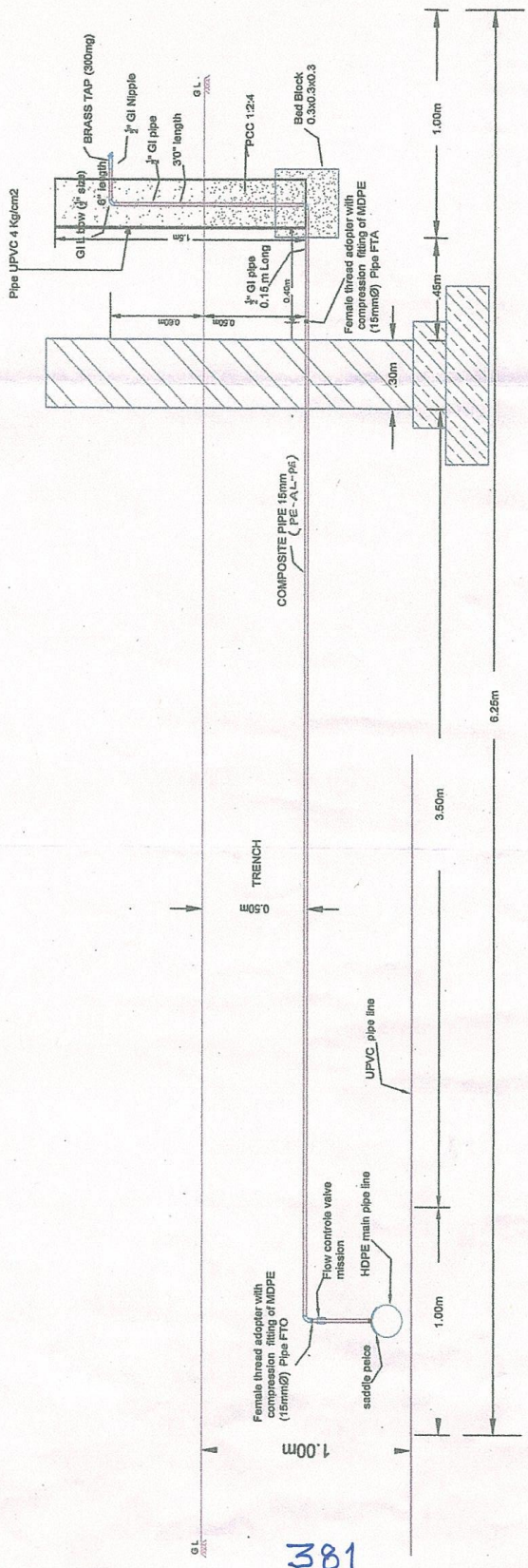

381



**नवीन यू.एस.ओ.आर.-2020 का विमोचन, दिनांक 01 जून 2020
माननीय मंत्री जी, छत्तीसगढ़ शासन, लोक स्वास्थ्य यांत्रिकी विभाग का विभागीय अधिकारियों के साथ छायाचित्र**



लोक स्वास्थ्य यांत्रिकी विभाग छत्तीसगढ़
ग्रामीण पेयजल शिकायत हेतु टोल फ्री नम्बर-18002330008